



MegaLine® cabling systems in copper
for DataCenter · Office · Industry · @home

The Quality Connection

LEONI



MegaLine® cabling systems

The range of products encompasses everything from the in-house production of copper data cables, ready-made patch cords and trunk cables with connection components through to complete cabling systems.

Everything from a single source >>

With its product spectrum in copper cable and connectivity, LEONI provides future-proof cabling systems for data center, floor and workplace cabling.

Welcome to the mega-store for cable and system solutions

Issue: May 2018 © LEONI Kerpen GmbH

The contents of this catalogue are protected by copyright.
All rights reserved.

All necessary planning documentation available online:
www.leoni-data.com

Subject to technical modifications, misprints and errors.

Safety instructions

Cables are to be used for the designated applications only.

Waiver

The specifications in this document are provided acc. to our best current knowledge. However, these specifications may not be considered an assurance of specific properties or suitability for specific purposes of the respective products. Such indications may not be interpreted as a misguidance for the violation of property rights or as an assurance of a corresponding license. The suitability of each product for any particular purpose must be checked beforehand with our specialists. Our policy is to continuously improve our materials and products. Therefore, we reserve the right to offer alternatives consistent with our manufacturing programme at the time of enquiry.

All information concerning material properties, fire performance, construction, electrical and technical data, prices etc. reflects our current level of knowledge and is provided on a non-binding basis. Dimensions and weights are indicative only. All specifications can be changed at any time without prior notification.

General conditions of sale and delivery

We refer to the currently valid General Conditions of Sale and Delivery which can be obtained from the respective companies.

Definitions

Some of the terms used in this document are not used consistently in the industry. To promote mutually intelligible business relationships and customer communications, however, LEONI strives to ensure consistent term usage. To avoid difficulties with interpretation, we refer you to www.leoni.com/en/company/copper-business/, where we have provided definitions of the terms that we use. The version applicable at the time of handover for this document is authoritative. These definitions form part of the contract. Insofar as terms defined there are used in this document, they have the meanings as defined there. We will also be happy to send you the definitions on request.

	page
The LEONI Group	4
Keeping you connected tomorrow	5
Great brands, great service	6
Technologies – investments in sustainable safety	7
Green Technology	8
MegaLine® copper data cable	10
• SPACE concept	12
• PoE on the advance	19
• Fire-resistant cables	24
• Type codes	34
• Cable types	35
• Product range	36
MegaLine® Connect100 Cu connectivity	104
• Introduction	106
• System overview (10 – 40 Gbit/s)	110
• Product range	112
MegaLine® Connect45 · MegaLine® Connect45 Pro Cu connectivity	120
• Introduction – MegaLine® Connect45	122
• System overview – MegaLine® Connect45 (1 – 10 Gbit/s)	126
• Product range (Connect45)	128
• System overview – MegaLine® Connect45 Pro (up to 10 Gbit/s)	139
• Product range (Connect45 Pro)	140
MegaLine® Cu patch cords / trunk cables	142
• MegaLine® Cu patch cords/trunk cables – product range	144
VarioLine® system periphery in copper and fiber	162
• VarioLine® CP – Consolidation Point programme	165
• VarioLine® UF – underfloor systems	169
• System overview	170
• Product range	172
Acceptance measurement	178
Alien Crosstalk	184
MegaLine® @home	186
Fields of application	192
Office	192
Industry	194
DataCenter	198
Index	202
LEONI news	203

The LEONI Group

Intelligent solutions for energy and data management



LEONI is a global provider of products, solutions and services for energy and data management in the automotive sector and other industries. The group of companies, listed on the German MDAX index, has more than 86,000 employees in 31 countries and generated consolidated sales of EUR 4.9 billion in 2017.

LEONI's largest customer group comprises the global car, commercial vehicle and component supply industry. LEONI furthermore supplies products and services to these markets: data communication & networks, healthcare, process industry, transportation, energy & infrastructure, factory automation, machinery & sensors as well as marine. An integrated network for research & development, production as well as distribution and service gives customers the assurance of tailor-made support at more than 90 locations around the globe. LEONI operates as a solutions provider with pronounced development and systems expertise.

Innovative solutions based on development and systems partnership

Especially in the automotive industry, LEONI offers substantial added value to motor vehicle manufacturers in both technological and commercial terms by being an innovation partner based on profound understanding of the overall system and by being involved in the early stages of development. In addition to standard and special cables as well as custom-developed wiring systems and related components, the Company's offering

also includes software solutions and such services as architecture design and simulation. LEONI concentrates its automotive research and development work on the sector's major trends such as electromobility, autonomous driving and connectivity – enhanced by lightweight construction solutions, multi-voltage and function integration, but also by logistics and engineering expertise.

Digital transformation thanks to intelligent products and smart services

LEONI pursues the aim of becoming a leading solutions provider of intelligent systems for the megatrends of energy transmission and data management. To achieve this, the Company's offering will in the future also include intelligent cables, cable systems and components – which is gaining importance particularly in the wake of digitalization and the development of fail-safe systems with a high level of connectivity. The Company is consequently enhancing its know-how in such fields as electronics, sensor technology and big data, and provides such customised smart services as predictive maintenance and error analyses. The digital transformation within LEONI manifests itself in digital processes and software expertise, which is used, for instance, to implement more automated production. Together with international customer networks and strategic partnerships, this is creating new, digital business models – individually tailored to customers' requirements.

For further information, please visit www.leoni.com

Keeping you connected tomorrow

Business Unit Datacom

LEONI's Business Unit Datacom ensures first-class, reliable data cabling in buildings and data centers. Numerous innovations and developments of today are already setting the standards of tomorrow.

Copper and fiber-optic cabling combined with specifically adapted system technology create data networks that maximise the operational performance of our customers. By always keeping the benefit and value for our customers in mind, we create solutions that facilitate next-generation technology migrations.

As globalisation, urbanisation and networking continue to expand, the technical requirements for materials, manufacturing processes and logistics grow more demanding. Last but not least, project cost pressures are also increasing. Cost-saving potential is tapped into throughout the entire planning and implementation process. and the sooner this

is incorporated into the process, the greater the volume of potential savings. LEONI is your partner here, helping to achieve optimisation from the earliest project phases such as planning, through to implementation and commissioning.

Put your trust in the best partner to suit your needs. Cabling, connectivity and complete cabling solutions from a single source, for investors, integrators, designers, installers and dealers.

This includes copper and fiber optic system solutions being extended by LEONI-branded halogen-free energy cables.

Continuous innovations in safety, environmental compatibility and energy efficiency complete the list of customer benefits. Offering on-site consultations and a wealth of experience, LEONI is your internationally-recognised project partner.

For further information, see www.leoni-data.com



Great brands, great service

Rely on the best partner to meet your needs

Our commitment to developing innovative products proves our dedication to our responsibility. In conjunction with our consulting services, we establish trust as we help our partners accomplish maximum safety for people and infrastructure.

Installers and retail receive their cabling, connectivity and complete cabling solutions from a single source. This includes system solutions in copper, aluminium and fiber optic technology as well as halogen-free energy cables with or without circuit integrity. Continuous innovations in safety, environmental compatibility and energy efficiency complete the list of customer benefits.

A global presence and consulting on site during all stages of a project as well as extensive experience gained from numerous projects and far-reaching synergies inside and outside the LEONI Group make us one of the most highly regarded partners in the field of building and infrastructure cabling at the international level.

Datacom – for maximum data integrity and bandwidth

From the very beginning of the digital data era, we have fulfilled data networking requirements for both the short term and the far future by using great innovation and a forward-looking approach. The profound expertise of the **Infrastructure & Datacom** Business Unit in copper and fiber optical cabling technologies represents a powerful advantage in structured cabling systems for industry, data centres and offices – the sustainable copper and glass fiber cables of our own production are among the safest and most innovative products in the primary to tertiary cabling market.

- **MegaLine**[®]
copper cables and passive system components
- **GigaLine**[®]
fiber optic cables and passive system components
- **VarioLine**[®] modular system periphery



Technologies – investments in sustainable safety

Universal use with extremely high functional integrity

Our development and production centres LEONI Studer (CH) and LEONI Kerpen (D) have one thing in common above all else : expertise. In extensive production areas, we work with state-of-the-art methods and systems in plastics processing, materials processing, extrusion technology, electron beam cross-linking and testing the entire range of products.

We use state-of-the-art production equipment to ensure that we can offer our customers the highest possible levels of product safety and quality. New and innovative plastics mixtures and cables are constantly being developed in modern laboratories. Our focus here is on improved insulating properties, higher temperature tolerances, longer lifetimes, easy handling and better safety features. Our test laboratories for flammability tests, HF technology and optical measurement technology safeguard our quality standards and promote innovation.

This is demonstrated by the large number of approvals and certificates coming from well-known independent testing institutes worldwide.

In the fire test laboratory, the fire-resistant properties of our products are tested by certified testers, technicians and engineers. With this capability, we are able to carry out testing to fulfil the wide-ranging measuring tasks in accordance with BS 6387 C.W.Z. , IEC 60331-11/21 and DIN 4102 Part 12, as well as customer-specific specifications and special testing.

Numerous national and international certificates provide proof of the company's power to innovate.

- **Halogen free**
IEC 60754-1, EN 50267-2-1
- **Corrosive effects of combustion gases**
IEC 60754-2, EN 50267-2-2
- **Smoke density**
IEC 61034, EN 61034
- **Flame retardancy**
IEC 60332-1, EN 60332-1, VDE 0482-332-1
- **Circuit integrity**
BS 6387 C.W.Z., DIN VDE 0472-814, EN 50200, EN 50362, IEC 60331-11/21, VdS 3423, VDE 0482-200
- **System integrity under fire**
DIN 4102 part 12
- **Non-flame propagating**
IEC 60332-3, EN 60332-3, VDE 0482-332-3 series
- **Construction Products Regulation**
EN 50575, EN 50399, EN 60332-1
- **IT cabling systems for offices**
EN 50173-2, ISO/IEC 11801
- **IT cabling systems for industry**
EN 50173-3, ISO/IEC 24702
- **IT cabling systems for data centers**
EN 50173-5, ISO/IEC 24764

Numerous national and international certificates confirm the company's ability to provide innovative solutions.



Green Technology

Our company aim is to combine innovation with sustainability. It is one of our central company goals.



Our vision is to create sustainable connections in technological harmony with the natural resources. The cycle of nature gives us the best model to emulate. It is our responsibility to learn from nature and make use of it while conserving it and treating it with care. The growing scarcity of the natural resources and the increasing burden on the environment require a rethink at all levels of society. For LEONI, sustainability is an integral part of group policy. We were the first cable manufacturer in the world to develop an integrated “green technology” programme.

While trends such as globalisation, mobility and urbanisation are crucial for market movements, our core principles are sustainability and global responsibility. This is why we have set ourselves the goal of becoming an innovative producer of cables for ecotechnology. Other points of vital interest to us are to detect the needs and requirements of tomorrow today and to supply the markets of the future with sustainable, future-proof solutions. We also view it as our responsibility to take an active role in shaping the markets for environmentally friendly energy production – such as solar thermal technology.

Green technology stands for the resource-conserving and low-emission production of sustainable quality cables made with low-pollution elements. We constantly work at optimising the efficiency with which resources are used in the manufacturing process by deploying energy-efficient machines or taking heat recovery measures. More and more locations in our global production network are environmentally certified according to the ISO 14001 standard.

In our worldwide operations as a leading European supplier of wires, optical fiber, cables and cable systems for communication and infrastructure projects, it is our responsibility to continuously optimise the sustainability and durability of our products, system solutions and services so as to reduce their impact on the environment. We have to increase the amount of environmentally compatible raw materials in our cable products as well as the recyclability of processed materials or components and in doing so create end products that are developed for the environmental standards of tomorrow today.

In conjunction with the ecological compatibility, future technologies are measured in terms of efficiency, service life, emission reduction and the conservation of natural resources. Innovative cable products and systems, holistic solutions and maximum performance in project management are the added value which we offer to our customers and business partners. These are also our cornerstones for strong connections into the future.



There are various environmental directives in the European Union (EU). Directive 2012/19/EU WEEE (Waste Electrical and Electronic Equipment) regulates the disposal of electrical and electronic equipment and components. The use of certain hazardous materials in electrical and electronic devices is defined by Directive 2011/65/EU RoHS 2 (Restriction of Hazardous Substances). Chemicals and materials in general are regulated by the law on chemical substances 1907/2006/EC REACH (Registration, Evaluation, Authorisation and Restriction of Chemicals).

This means avoiding the following substances, among others:

- Polybrominated diphenyl ether (PBDE)
- Decabromodiphenyl ether (DecaBDE)
- Perfluorooctane sulfonate (PFOS)
- Pentabromodiphenyl ether (PentaBDE)
- Octabromodiphenyl ether (OctaBDE)
- Lead (Pb)
- Mercury (Hg)
- Cadmium (Cd)
- Hexavalent chromium (Cr VI)
- Polybrominated biphenyls (PBB)



Cables and conductors and their associated connectors are only affected by Directive 2012/19/EU WEEE where they are an internal part of the listed equipment and components.

Cables and conductors have been regulated separately in 2011/65/EU RoHS 2 since 2013 (category 11 or defined as an internal component of the respective product). This does not pertain to optical fiber cable, energy cable (> 250 V) and cable with fixed installation, e.g. in buildings. The only permissible marking according to RoHS 2 is the CE marking, which is printed on the product package.

EU Directive 2012/19/EU on waste electrical and electronic equipment.

EU Directive 2011/65/EU on the restriction of the use of certain hazardous substances in electrical and electronic equipment.

EU Regulation 1907/2006/EC (REACH) – the EU chemicals regulation.



REACH

What does REACH mean?

REACH stands for Registration, Evaluation, Authorisation and Restriction of Chemicals.

REACH represents a fundamental harmonisation and simplification of previous chemicals law and applies in all EU Member States.

REACH introduced a so-called candidate list for substances of very high concern (SVHC), which are subject to certain information obligations and should be substituted in the long term. The list of candidate substances is updated twice yearly by the European Chemicals Agency (ECHA) in Helsinki.



MegaLine®
Copper data cable

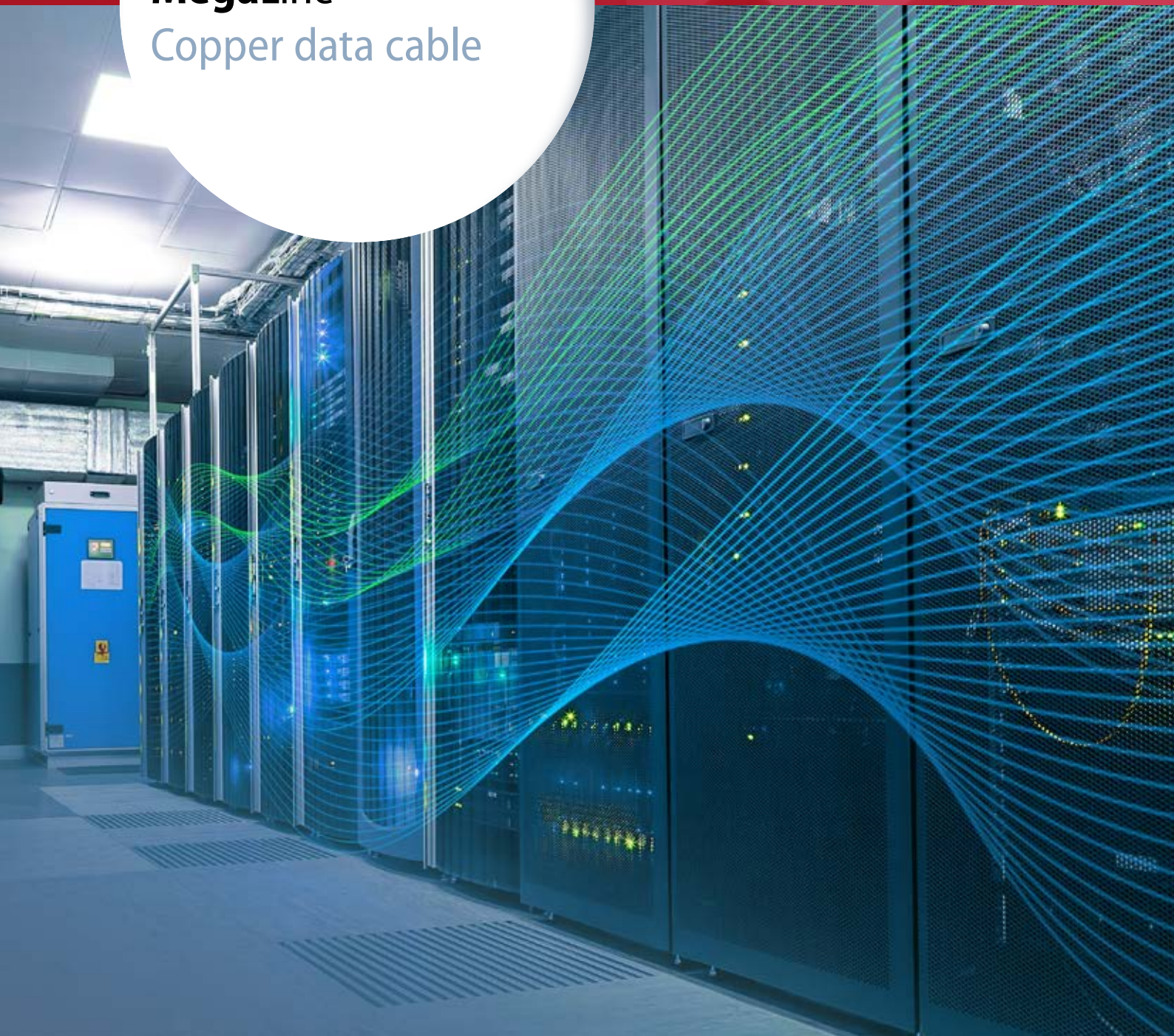

MegaLine® copper data cable	page
Space concept	12
SPACE – Security	13
SPACE – Performance	14
SPACE – Application	16
SPACE – Construction	17
SPACE – EMC	18
PoE on the advance	19
Benefits of PoE	20
What to note when wiring	21
Fire-resistant cables according to the EU Construction Products Regulation	24
Safety in the event of a fire	25
Fire safety of cable systems	26
CE marking and declaration of performance	27
Fire classifications and proof of conformity	28
Overview of fire testing	29
Cable types with Euroclass B2 _{ca} s1a d1 a1	31
On the safe side with LEONI	32
Data cable colour code acc. to CPR classes	33
Type codes	34
Cable types	35

MegaLine® copper data cables							from page	
		Simlex	Duplex	B2 _{ca}	C _{ca}	E _{ca} /D _{ca}		
dc	MegaLine® G20 S/F	✓		✓	✓	✓	Cat. 8.2	Class F _A + 36
dc	MegaLine® G20 S/F Mini	✓					Cat. 8.2	Class F _A + 38
o dc	MegaLine® G12-150 S/F	✓	✓	✓	✓	✓	Cat. 7 _A +	Class F _A + 40
o	MegaLine® F10-130 S/F	✓	✓	✓	✓	✓	Cat. 7 _A	Class F _A 42
o dc	MegaLine® F10-125 S/F	✓	✓	✓	✓	✓	Cat. 7 _A	Class F _A 44
o dc	MegaLine® F10-115 S/F	✓	✓	✓	✓	✓	Cat. 7 _A	Class F _A 46
o dc	MegaLine® F6-90 S/F	✓	✓	✓	✓	✓	Cat. 7	Class F 48
o	MegaLine® F6-90 S/F CI	✓					Cat. 7	Class F 50
o	MegaLine® E5-70 S/F	✓	✓				Cat. 6 _A	Class E _A 52
o	MegaLine® E5-70 F/F	✓	✓	✓	✓		Cat. 6 _A	Class E _A 54
o	MegaLine® E5-60 U/F	✓	✓		✓		Cat. 6 _A	Class E _A 56
o	MegaLine® E2-45 U/F	✓	✓				Cat. 6	Class E 58
o	MegaLine® E2-30 U/U	✓					Cat. 6	Class E 60
o	MegaLine® D1-20 SF/U	✓	✓				Cat. 5	Class D 62
o	MegaLine® Pro 1500	✓	✓				Cat. 7 _A +	Class F _A 64
o	MegaLine® Pro 1300	✓	✓				Cat. 7 _A	Class F _A 66
o	MegaLine® Pro 1200	✓	✓				Cat. 7 _A	Class F _A 68
o	MegaLine® Pro 1000	✓	✓				Cat. 7	Class F 70
dc	MegaLine® G20 S/F flex	✓					Cat. 8.2	Class F _A + 72
o	MegaLine® F10-120 S/F flex	✓					Cat. 7	Class F _A 74
o dc	MegaLine® F6-90 S/F flex	✓					Cat. 7	Class F 76
o	MegaLine® D1-20 SF/U flex	✓					Cat. 5	Class E _A 78
o	MegaLine® F10-130 S/F (L)2Y	✓					Cat. 7 _A	Class F _A 80
o	MegaLine® F10-130 S/F QH	✓					Cat. 7 _A	Class F _A 82
o	MegaLine® F10-130 S/F Vö	✓					Cat. 7 _A	Class F _A 84
o	MegaLine® F10-115 S/F V	✓					Cat. 7 _A	Class F _A 86
o	MegaLine® F6-90 S/F 2Y	✓					Cat. 7	Class F 88
o	MegaLine® D1-20 SF/U 2Y	✓					Cat. 5	Class D 90
o	MegaLine® D1-20 SF/U HQH	✓					Cat. 5	Class D 92
o	MegaLine® F10-120 S/F 11Y flex	✓					Cat. 7 _A	Class F _A 94
o	MegaLine® F6-70 S/F 11Y flex	✓					Cat. 7	Class F 96
o	MegaLine® D1-20 SF/U flex CI	✓					Cat. 5	Class D 98
o	MegaLine® D1-20 S/U 11Y superflex	✓					Cat. 5	Class D 100
h	MegaLine® home 600	✓					Cat. 7	Class F 102
o	Office cables							
dc	Data center cables							
o	Industrial cables							
h	@home cables (Smart Home)							

SPACE concept

Finding the right data cable

S Security
P Performance
A Application
C Construction
E EMC



LEONI's SPACE concept is based on a pragmatic and clearly structured matrix. This decision-making aid will help you to find the right data cable for your application faster.

The concept is based on the classification of the five main selection criteria for determining the potential overall performance of a data cable:

Security · Performance · Application · Construction · EMC

It also allows the value for money to be assessed and makes room for alternative technical and economic scenarios. The demands made on the segment in question rise in step with the increase in the SPACE index.

Example of a data cable with the code S₃ P₄ A₄ C₅ E₅:

- S₃** It passes the fire test according to IEC 60332-3-24 (Security Level 3)
- P₄** It meets the minimum requirements of Class F_A (Performance Level 4)
- A₄** It is designed for applications with more than 10 GbE (Application Level 4)
- C₅** It consists of a conductor with AWG 22 (Construction Level 5) and thus has low attenuation values and an increased max. current rating
- E₅** The coupling attenuation is > 80 dB (EMC Level 5)

With the VDE kitemark (an independent hallmark of quality including production monitoring), LEONI guarantees the SPACE quality features at all times.

SPACE matrix:

Security (fire behaviour)

S	1	2	3	4	5
	IEC 60332-2-2	IEC-60332-1-2 E _{ca} /D _{ca}	IEC-60332-3-24 E _{ca} /D _{ca}	EFP Grade 1 C _{ca}	EFP Grade 2 B2 _{ca}

Performance (cable class, bandwidth)

P	1	2	3	4	5
	> Class E > 250 MHz	> Class E _A > 500 MHz	> Class F > 600 MHz	> Class F _A > 1000 MHz	> Class F _A + > 1200 MHz

Application (Ethernet, TV)

A	1	2	3	4	5
	> 100 MbE	> 1 GbE	up to 10 GbE	> 10 GbE	> 10 GbE TV

Construction (conductor dimension, tensile strength)

C	1	2	3	4	5
	AWG 27	AWG 26/25	AWG 24	AWG 23	AWG 22

EMC (coupling attenuation)

E	1	2	3	4	5
	> 40 dB	> 50 dB	> 60 dB	> 70 dB	> 80 dB

SPACE – Security

Fire behaviour



As a result of the constant increase in the installed basis and the installation density, the fire behaviour of data cables is an important safety criterion. When manufactured according to the legal regulations and installed correctly, data cables cannot cause a fire. If they do catch fire, however, they can inflame and spread the fire.

One of the aims here is to prevent the propagation of fire and the resulting damage by using flame-retardant, halogen-free cable designs.

MegaLine® data cables have improved fire protection characteristics:

- Extremely low smoke development according to IEC 61034
→ Facilitates rescue and removal activities
- Low toxicity (dioxins are not produced)
→ Reduces the risk of poisoning
- Halogen free according to IEC 60754-2
→ No consequential damage to material assets as a result of corrosion
- Low fire load values
→ Limits the exacerbating effects on the source of the fire
- High oxygen index (OI up to 45)
→ Reduces the flammability

Security (fire behaviour)

S	1 IEC 60332-2-2	2 IEC-60332-1-2 E _{ca} /D _{ca}	3 IEC-60332-3-24 E _{ca} /D _{ca}	4 EFP Grade 1 C _{ca}	5 EFP Grade 2 B2 _{ca}

The five security levels with regard to fire propagation/flame retardancy:

S₁ IEC 60332-2-2

Testing of the vertical propagation in a core or single cable.
Test method: incandescent flame.

S₂ IEC 60332-1-2

Testing of the vertical propagation in a core or single cable. Test method: 1 KW flame. A flame is applied to the lower end of a vertical sample of the cable about 60 cm in length for about 60 seconds using a type of Bunsen burner. After removal of the burner, the flames must go out by themselves. The parts of the cable damaged by the flames must not reach its upper end (distance: 50 mm).

S₃ IEC 60332-3-24

Testing of the flame propagation in an arrangement of several cables, a so-called cable bundle, is carried out according to IEC 60332-3-24. In this cable bundle test, a flame is applied to the lower part of the test samples on a vertical ladder with a length of 360 cm using a high-performance burner. During



and after intensive application of the flame for a test period of 20 minutes, the cables must not burn higher than 250 cm.

S₄ EFP (Enhanced Fire Performance) Grade 1

In this cable bundle test, a flame is applied to the lower part of the test samples on a vertical ladder with a length of 360 cm using a high-performance burner. During and after intensive application of the flame for a test period of 20 minutes, only approx. 1 m of the section to which the flame is applied may burn. Immediately after removal of the flame, the self-extinguishing process must start. Only specially designed data cables can stand up to this exacting fire test.

S₅ EFP (Enhanced Fire Performance) Grade 2

This stricter security level is application-specific.

Security levels **S₃**, **S₄** and **S₅** are used in particular where high and very high security measures are required for the protection of persons or material assets. For example in hospitals, schools, hotels, airports, railway stations, departments stores, power and electricity plants, data centers, banks, insurance companies and alarm systems.

SPACE – Performance

Cable class / bandwidth



In cabling systems, a service life of 10 to 15 years is expected. This requires far-sighted planning of the required performance of cabling systems and their components.

Because of their hard-fought compromises and in view of fast-increasing transmission rates, international standards often fall short. Since the development of 10 Gigabit Ethernet, none of the cabling classes below Class F can be said to meet the demands of the future.

MegaLine® data cables have excellent transmission performance. They offer high security reserves and are always one step ahead of the standard.

MegaLine® – an investment with a future!

Performance (cable class, bandwidth)

P	1	2	3	4	5
	> Class E > 250 MHz	> Class E _A > 500 MHz	> Class F > 600 MHz	> Class F _A > 1000 MHz	> Class F _{A+} > 1200 MHz

The five classes for performance (cabling class, bandwidth) have very high reserves with regard to the standard involved.

P₃ better than Class F (600 MHz)

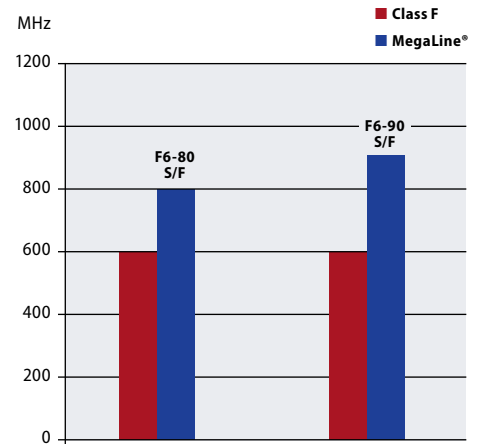

Example: **MegaLine® F6-90 S/F**

Better than Category 7 according to EN 50288 and IEC 61156
excellent NEXT, excellent shielding characteristics
(pairs and overall shielding), low skew

P₁ better than Class E (250 MHz)

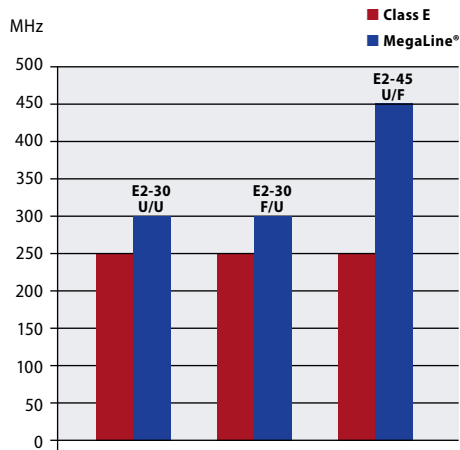

Example: MegaLine® E2-45 U/F

Better than Category 6 according to EN 50288 and IEC 61156, very good NEXT, low skew

P₂ better than Class E_A (500 MHz)

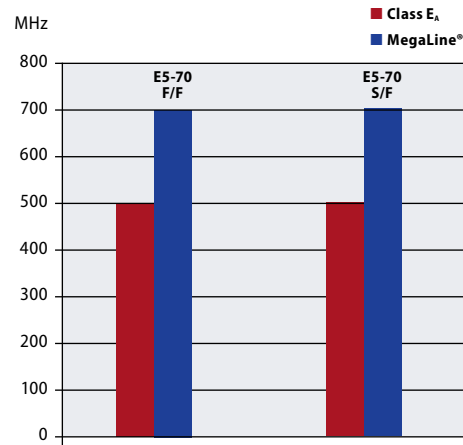

Example: MegaLine® E5-70 S/F

Better than Category 6_A according to EN 50288 and IEC 61156 very good NEXT, very good shielding characteristics (pairs and overall shielding), low skew

P₄ better than Class F_A (1000 MHz)

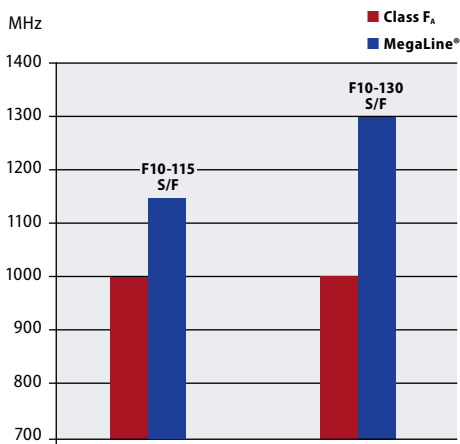

Example: MegaLine® G12-150 S/F

Better than Category 7_A according to EN 50288 and IEC 61156, excellent NEXT, low attenuation, excellent shielding characteristics (pairs and overall shielding), low skew

P₅ better than Class F_{A+} (1200 MHz)

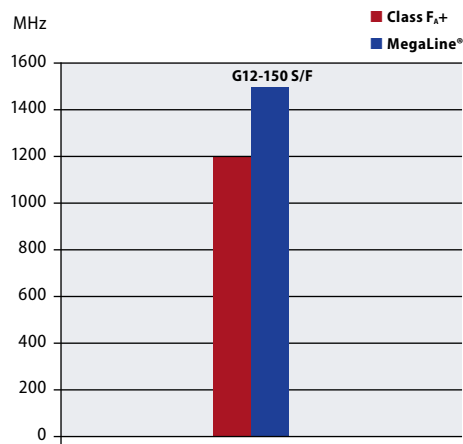

Example: MegaLine® G12-150 S/F

Better than Category 7_A according to EN 50288 and IEC 61156 excellent NEXT, low attenuation, excellent shielding characteristics (pairs and overall shielding), low skew

SPACE – Application

Ethernet/TV

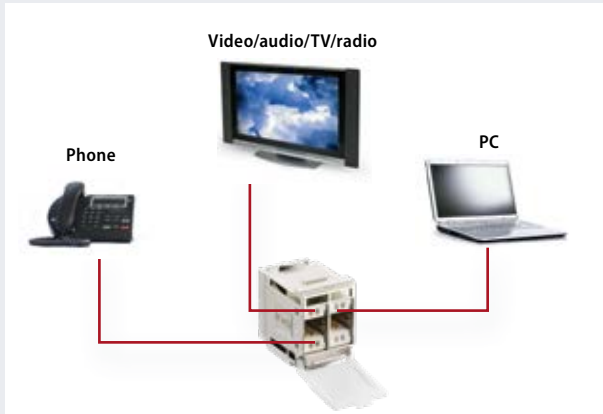

The large security reserves mean that multimedia applications such as TV and transmission protocols with high bandwidth requirements such as 10 Gigabit Ethernet and 8 Gigabit Fiber Channel can be transmitted over 100 m. Experts have calculated that, as far as we know today, MegaLine® Category 7_A data cables allow transmission rates of as much as 100 Gbit/s.

The use of low-loss broadband S/FTP cables with individual or overall shielding in conjunction with multimedia cabling systems allows so-called cable or service sharing.

Cables and connectors form a perfect symbiosis:

4 pairs, 4 connecting clips – each with GHz performance.

This allows parallel, simultaneous use of different applications via one cable and one connector: data, voice and images.

Multimedia systems do not need to cost more than conventional systems, in which an individual cable and an individual connector is usually required for each service. This allows savings of up to 50 % of the necessary cables, connectors, wall outlets and patch panels.

Multiple use reduces the system costs by 15 to 30 % (depending on the services used). The reduction in the number of cables and wall outlets actually required usually also allows reductions in the costs for cable ducts, switching cabinets, etc.

But MegaLine® data cables are capable of more

The supply of current (up to 350/600 mA) and voltage (up to 48 V) can be provided via PoE/PoE+ (according to IEEE 802.3a/at). The current is fed in centrally via the floor distributor or switch. Devices such as IP telephones, web cameras, wireless LAN access points, etc. are supplied via the telecommunications outlet. The voltage is tapped via a phantom circuit or two unassigned pairs.

Application (Ethernet, TV)

A	1	2	3	4	5
	> 100 MbE	> 1 GbE	up to 10 GbE	> 10 GbE	> 10 GbE TV

The SPACE concept provides five different application levels.

A₁ > 100 Mbit/s (Fast Ethernet) IEEE 802.3 u

A₂ > 1000 Mbit/s (Gigabit Ethernet) IEEE 802.3 ab

A₃ ≤ 10,000 Mbit/s (10 Gigabit Ethernet) IEEE 802.3 an

A₄ > 10,000 Mbit/s (10 Gigabit Ethernet) IEEE 802.3 an

A₅ > 10,000 Mbit/s (10 Gigabit Ethernet) and TV
IEEE 802.3 an and multimedia

SPACE – Construction

Conductor dimension



High-precision conductor and core geometries, optimally matched lay lengths in the pairs and the use of very high-quality insulation and sheath materials are the characteristic features of our range of cables.

Our cables are produced on ultra-modern equipment which corresponds with the "state of the art" as a result of procedural innovations. The use of physical foaming in the manufacture of high-frequency cores allows excellent, uniform electrical and geometrical characteristics to be achieved. Double skin layers ensure excellent mechanical stability while patented stranding techniques demonstrate technical leadership.

The designs have low outer diameters, thus allowing high packing densities and small bending radii. The weight reductions and the robust cable construction offer advantages for assembly and installation, even under difficult conditions.

The five different conductor classes describe the permitted tensile stress during installation and the conductor resistance.

Note > The copper sales factor is a purely commercial calculation factor that is used to calculate the total price of a cable. Although usually expressed in the trade in kg/km, the copper sales factor does not indicate the quantity or weight of the actual copper contained in the cable.

It is a purely arithmetic calculation factor that does not give any direct indication of the amount of copper used in the cable.

Construction (conductor dimension, tensile strength)

C	1	2	3	4	5
	AWG 27	AWG 26/25	AWG 24	AWG 23	AWG 22

The current-handling capacity for a maximum ambient temperature of 60 °C and the maximum installation lengths in the transmission channel can be derived from this on request.

C₁ AWG 27 (7x0,14 mm/0.112 mm²)

Tensile stress: max. 40/20 N (4 p/2 p)
Conductor resistance: max. 170 Ω/km

C₂ AWG 26 or AWG 25

- C₂₁ AWG 26 (7x0.16 mm/0.14 mm²)
Tensile stress: max. 60/30 N (4 p/2 p)
Conductor resistance: max. 145 Ω/km
- C₂₂ AWG 25 (7x0.18 mm/0.175 mm²)
Tensile stress: max. 70/35 N (4 p/2 p)
Conductor resistance: max. 120 Ω/km

C₃ AWG 24 (0.51 mm/0.205 mm²)

Tensile stress: max. 90/45 N (4 p/2 p)
Conductor resistance: max. 95 Ω/km

C₄ AWG 23 (0.57 mm/0.258 mm²)

Tensile stress: max. 110/55 N (4 p/2 p)
Conductor resistance: max. 75 Ω/km

C₅ AWG 22 (0.64 mm/0.325 mm²)

Tensile stress: max. 130/65 N (4 p/2 p)
Conductor resistance: max. 57 Ω/km

SPACE – EMC

Coupling attenuation



Electromagnetic compatibility (EMC)

This refers to the ability of devices, systems and plants to function satisfactorily in an electromagnetic environment without negative effects on other devices, systems or plants. EMC legislation prescribes the electromagnetic compatibility of devices, systems and plants. The limits for the emission of interference and the immunity to interference which must be observed are regulated by EN 55022 (Class B) and EN 50082-1/2 / EN 55024.

A data cable must resist electromagnetic influences coming from the outside to the inside (immunity to interference) and from the inside to the outside (emission of interference). The susceptibility of data cable systems to interference increases in step with the transmission frequency and the data rates (currently 10 Gigabit Ethernet).

Electromagnetic Compatibility			
Construction	U/UTP	F/UTP	S/FTP
Symmetrical characteristics	+++	++	++
Shield characteristics	low	+	+++
Installation environment influence	high	moderate	low

The main danger is increasingly a result of the alien crosstalk between adjacent data cables. Depending on their construction, data cables have different capabilities with regard to the prevention or reduction of interference.

- Unshielded data cables have very good symmetry characteristics but are not shielded against internal, external or adjacent sources of interference. They are endangered to a high degree by the environment in which they are installed.
- Data cables with individual or overall shielding have very good symmetry characteristics and good or even very good shield characteristics. The EMC is very good or even excellent. Interference coming from the installation environment (adjacent data cables) can be ruled out completely.

MegaLine® data cables with dual shielding achieve values of > 80 dB to 1000 MHz, thereby suppressing incoming or outgoing potential interference by a factor of >10,000. Cables with individual and overall shielding (S/FTP) have excellent EMC, making them an obvious choice for the fail-safe transmission of high data rates such as those offered by 10 Gigabit Ethernet.

EMC (coupling attenuation)

E	1	2	3	4	5
	>40 dB	>50 dB	>60 dB	>70 dB	>80 dB

With the MegaLine® SPACE concept, LEONI provides five different EMC levels to choose from.

The evaluation criterion is the coupling attenuation (interference power suppression). As the sum of the shielding attenuation and the symmetry attenuation, the coupling attenuation is the "be-all and end-all" for the assessment and comparison of the overall EMC behaviour of different types of data cable.

E₁ coupling attenuation > 40 dB

Interference suppression exceeding a factor of 100

E₂ coupling attenuation > 50 dB

Interference suppression exceeding a factor of 300

E₃ coupling attenuation > 60 dB

Interference suppression exceeding a factor of 1,000

E₄ coupling attenuation > 70 dB

Interference suppression exceeding a factor of 3,000

E₅ coupling attenuation > 80 dB

Interference suppression exceeding a factor of 10,000

PoE (Power over Ethernet) on the advance

Category 7_A data cables tolerate higher power loads

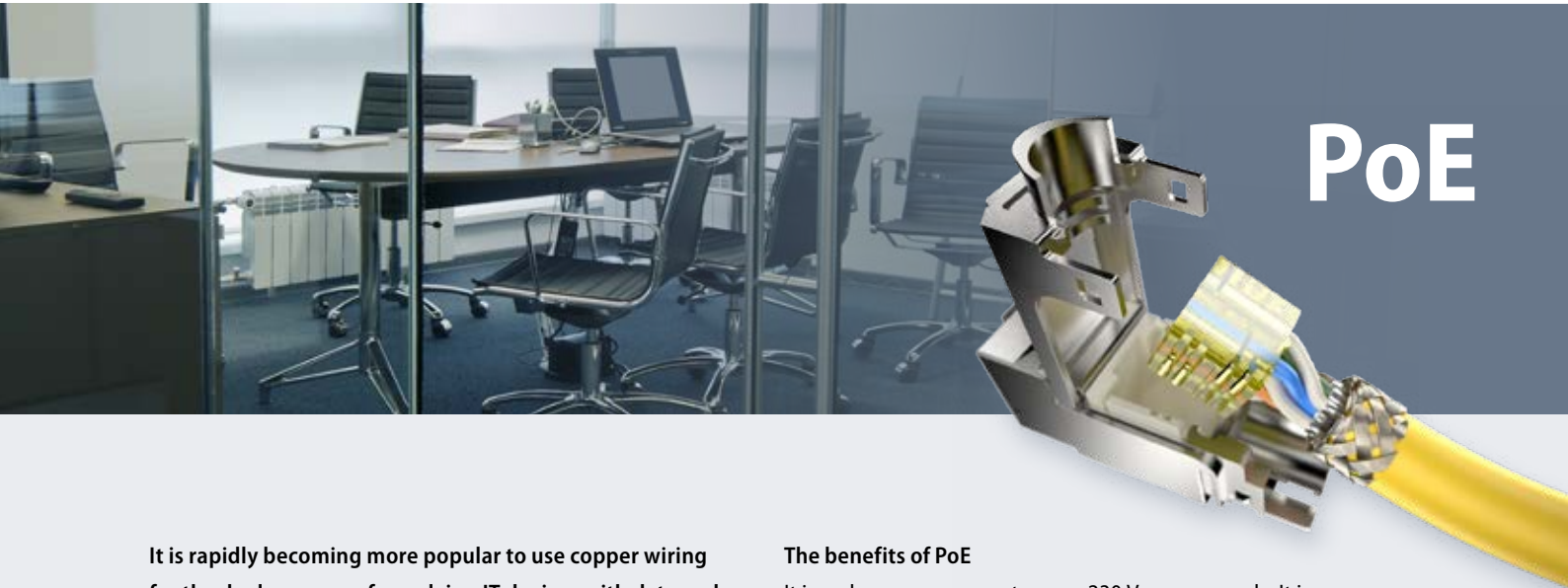

It is rapidly becoming more popular to use copper wiring for the dual purpose of supplying IT devices with data and energy simultaneously. More and more users are beginning to turn to the "Power over Ethernet" (PoE) technology that has been designed to do this.

The benefits of PoE

It is no longer necessary to use a 230 V power supply. It is now possible to supply end-user devices with up to 100 W (PoE++) rather than the previous 15W (PoE) or 30W (PoE+), supplied via 4-pair data cables.

Find out more

LEONI provides information on future developments and applications, looking into the question of which data cables and connectors are suitable for transmitting electric current.

Technical information

The standard IEEE 802.3af (PoE) allows energy supply to Ethernet devices with an output of 15 W via data cabling. Here the reliable amperage is 175 mA per conductor (350 mA per pair).

In the case of IEEE 802.3at (PoE+) the output is 30 W. The reliable amperage in this case is 300 mA per conductor (600 mA per pair).

	PoE	PoE+	PoE++
Standard	IEEE 802.3af-2003	IEEE802.3at-2009	IEEE802.3bt-2018
Useful power for the PD	13 W	25 W	60 – 100 W
PD voltage	37 – 57 V	42.5 – 57 V	44 – 57 V
Max. power consumption per pair	350 mA	600 mA	1000 mA

A current-carrying circuit is required (one pair) for supply and return wiring.

In the case of Cisco's proprietary UPoE technology (Universal Power over Ethernet), two pairs are used for the supply and return wiring (maintaining the current load for each conductor). This allows the output to be doubled to 60 W.

The IEEE 802.3bt (PoE++) standard is also referred to as four-pair Power over Ethernet (4PPoE). So far, only two of the four wire pairs of a data cable have been used in PoE, so all 4 pairs are used for power transmission of up to 100 W, with a permissible current of 500 mA per conductor.

Benefits of PoE

The PoE-capable switch used (Power Sourcing Equipment – PSE) offers enormous benefits in conjunction with PoE-capable end devices (Powered Devices – PD):

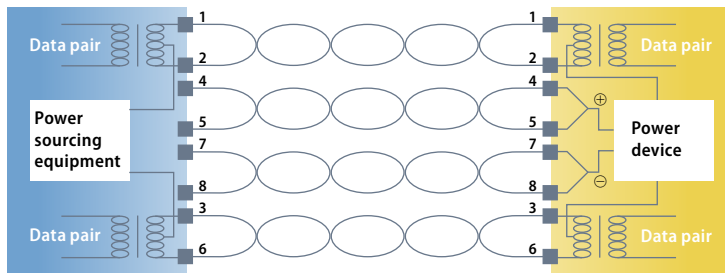

Core block diagram for PoE (from IEC 62652)

- **Saves 230 V energy supply**
(cable and socket)
- **Internationally secured compatibility**
(based on international standardisation)
- **Comprehensive management and monitoring options**
- **Reduced energy costs**
due to needs-oriented routing of energy and deactivation of unused ports
- **Fail-safe**
due to central, uninterrupted power supply (UPS).

These applications are supported

There are now numerous end devices that support and use PoE or PoE+ A number of these are shown here, but this selection by no means claims to be exhaustive. In addition, new applications are to be developed which require a power supply of up to 100 W.

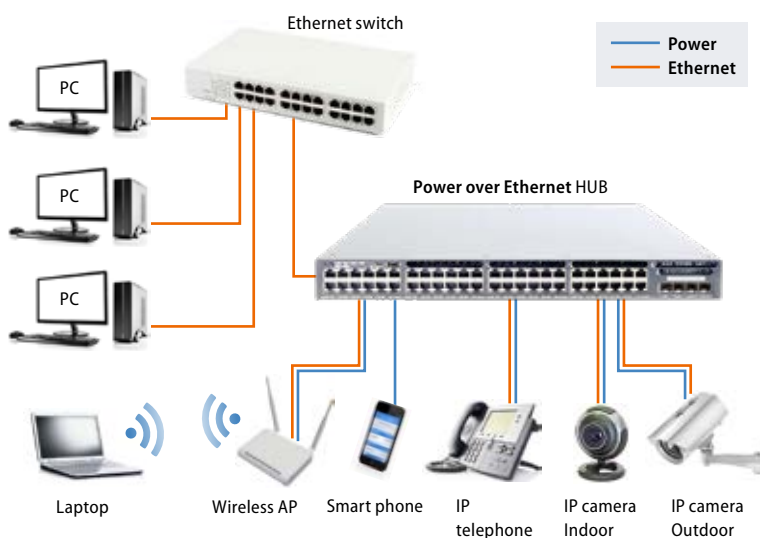

Examples of applications for PoE

PoE (15 W)

- IP telephones
- IP cameras
- Wireless LAN access points
- Bluetooth access points

PoE (30 W)

- Devices for the high-speed WLAN standard IEEE 802.11n
- Outdoor IP camera with heat, pan, tilt and zoom function
- Access control systems with controller, reading devices and lock system
- Video IP telephone

PoE (up to 100 W)

- Nursing call system in the healthcare sector
- Credit card reading devices and printers, e.g. in retail
- Laptops, thin-client computers
- Lighting (LED), building management
- Industrial applications, e.g. step motors
- Bluetooth access points

What to note when wiring

Data cabling was not originally designed for energy transmission at all. Nonetheless, dual use as desired is possible if the defined framework conditions are taken into account and suitable components selected.

The following points must be taken into account, however:

- >> **Overheating of the data cable**
- >> **Contact burn in connectors**

>> Overheating of the data cable

The increased power levels involved with the use of PoE, combined with cable accumulation in the installation duct and poor heat dissipation, can lead to perceptible increases in temperature in the data cables, potentially rising to dangerous levels in extreme cases.

Cable warming depends on the following factors:

- Current load (depending on the PoE standard used)
- Cable design (in particular conductor cross-section)
- Number of cable bundles in the installation channel
- Installation environment (heat release)
- Ambient temperature

The correct cable design makes a crucial contribution in minimising cable warming.

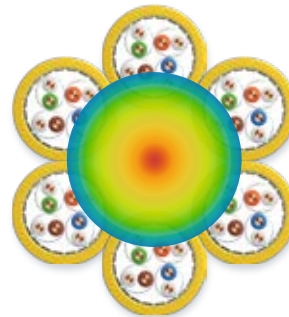

Application example for PoE

The rule of thumb is:
the higher the category, the less the warming!

The higher the category, the larger the conductor cross-section, the less the direct current resistance and therefore the less heat loss, too.

In the example shown from ISO/IEC TR 29125, Category 7_A cables exhibit 36 per cent lower heating as compared to Category 5 data cables.

Cable warming based on cable category (from ISO/IEC TR 29125)

Size of cable cluster (no. of cables)	Temperature increase in °C				
	CAT 5	CAT 6	CAT 6 _A	CAT 7	CAT 7 _A
1	0.8	0.6	0.6	0.6	0.6
7	1.4	1.1	1.0	1.0	0.9
19	2.6	2.1	1.8	1.8	1.6
37	4.7	3.7	3.2	3.2	2.9
61	6.9	5.5	4.8	4.8	4.4
91	9.7	7.7	6.7	6.7	6.2
127	13.1	10.4	9.0	9.0	8.3
169	16.9	13.5	11.7	11.7	10.8

-36%

» Overheating of the data cable

Another generally neglected effect is the increase in attenuation – caused by the rise in temperature and the reduction in range which this derives from. This can lead to incorrect transmission and in extreme cases result in system failure.

Here, shielded data cables offer clear benefits over unshielded data cables due to the lower temperature coefficient.

Example 1 – unshielded

Class D(a) at 60 °C with Cat.5 cable UTP

$$H_{60^{\circ}\text{C}} = (109 \text{ m} - 10 \times 1.5 \text{ m}) - (0.4 / 100 \times 20 \times 94 \text{ m}) - (0.6 / 100 \times 20 \times 94 \text{ m}) = 75 \text{ m}$$

Example 2 – shielded

Class D(a) at 60 °C with Cat. 5 cable STP

$$H_{60^{\circ}\text{C}} = (109 \text{ m} - 10 \times 1.5 \text{ m}) - (0,2/100 \times 40 \times 94) = 86 \text{ m (+15 %)}$$

Equation for horizontal transmission links

Model	Model equation		
	Class D	Class E and E _A	Class F and F _A
a) Through connection TO	$H = 109 - F \times X$	$H = 107 - 3 - FX$	$H = 107 - 2 - F \times X$
b) Marshalling TO	$H = 107 - F \times X$	$H = 106 - 3 - FX$	$H = 106 - 2 - F \times X$
c) Through-connection SP – TO	$H = 107 - F \times X - C \times Y$	$H = 106 - 3 - F \times X - C \times Y$	$H = 106 - 2 - F \times X - C \times Y$
d) Marshalling SP – TO	$H = 105 - F \times X - C \times Y$	$H = 105 - 3 - F \times X - C \times Y$	$H = 105 - 2 - F \times X - C \times Y$

H = max. length of tertiary cable (m)

F = total length of marshalling cords, marshalling pairs, device connection and device connector cords (m)

C = length of collection point cable (m)

X = relation between the insertion loss of the flexible cable (dB/m) and the insertion loss of the tertiary cable (dB/m)

Y = relation between the insertion loss of the collection point cable (dB/m) and the insertion loss of the tertiary cable (dB/m)

At temperatures above +20 °C *H* should be reduced in shielded cables by 0.2 % per 1 °C and in unshielded cables by 0.4 % per °C (+20 °C to +40 °C) and by 0.6 % per 1 °C (> +40 °C to +60 °C).

Our recommendation for the right data cable

- Shielded cable with the highest possible category: e.g. Category 7_A
- Large conduction cross-section (AWG 22)
- If required – special designs with permitted operating temperature > 60 °C

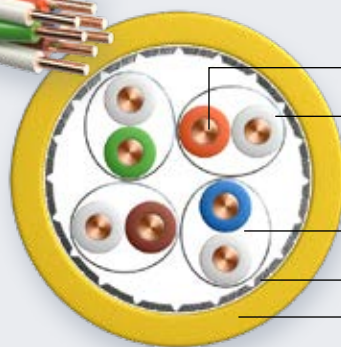

Conductor	Bare copper wire, AWG 22/1
Insulation twisting element	Cellular PE, core Ø: nominal value 1.6 mm Pair
Individual shielding Twisting	Aluminium bonded polyester foil, metal on the outside (PIMF) 4 pairs
Overall shielding	Tinned copper braid
Outer sheath	Halogen-free, flame-retardant compound

S/FTP data cable with cross-section AWG22/1
e.g. MegaLine® F10-130 S/F

» Contact burn in connectors

In connection technology, removing a plug under load can cause damage – so-called contact burn – due to the occurrence of an electric arc or sparking. An irreversible impairment of the contacts is caused, possibly even failure.

A potential remedy here is to use the appropriate port power management – i.e. first switch off the power supply, then remove the plug.

However, intentional or unintentional removal of the plug under load cannot be entirely avoided.

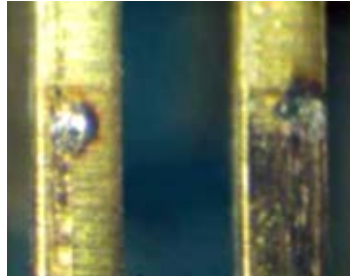

Contact burns in connection technology – shown here: a RJ45 socket (from IEC 62652)

Our recommendation for your choice of connection technology: **use staggered contact and insulation zones – over and above the relevant connector standards.**

Certified safety

MegaLine® Connect100 and MegaLine® Connect45

For this reason, LEONI had the product families MegaLine® Connect100 and MegaLine® Connect45 independently tested according to IEC 60512-99-001 and IEC 60512-9-3.

For this purpose, the socket/plug combinations were exposed to frequent insertion cycles under load. The permitted deviation of transition resistances (max. 20 MΩ) is easily maintained – **which means certified safety!**



MegaLine® Connect100 with staggered contact and insulation zones

Summary and outlook

Thanks to Power Ethernet, numerous IT devices are now able to do without a 230 V power supply. This technology enables buildings and offices to be planned and operated more intelligently and with greater energy efficiency.



Our contribution to green IT in buildings.

Not least due to the increase in power levels to be expected, LEONI recommends the use of shielded data cables of Category 7_A with conductor dimension AWG 22 and connection technology with staggered contact and insulation zones.

Fire protection cable in accordance with the EU Construction Products Regulation

Maximum safety with B2_{ca} cables by LEONI

Fire provides heat, light and a comforting sense of security.

But it can also be potentially fatal and result in horrific devastation.



Safety in the event of a fire

Where fires occur



One-third of all fires occur in buildings. Numerous deaths due to gas and smoke poisoning are the consequence. The average length of time from the development of a fire until the rollover (pyrolysis gases) has decreased drastically in recent years.



- 1950: 15 minutes
- 1985: 5 minutes
- 2010: 3 minutes

As a result, the available time for a possible escape from the building has also been drastically reduced.



This situation has prompted construction material manufacturers to produce increasingly better and more flame-retardant products.

Fire safety of cable systems

Save lives, impede fires, minimise consequential damage



Saving lives, impeding fires and minimising consequential damages are the priorities when fires break out. Electrical and optical cables must also have their part to play, especially given the fact that cable density in modern buildings is constantly increasing. How can cables contribute to a positive behaviour in the event of a fire and/or what dangers are posed by obsolete, insufficiently fire-resistant cables? These questions can be assigned to three categories:

1. The cable must not make a significant contribution to fire propagation. In particular, it must not propagate the fire from one storey to the next. It must also be ensured that there are no droplets and particles that contribute to fire propagation.

2. Smoke and toxic gases must be avoided, because they make safe building evacuation and impede the efforts of rescue or make them impossible. Most cases of death in the event of a fire can be traced to smoke and toxic gases, not to the fire itself. Therefore, this aspect should actually be given top priority.

3. The rebuilding phase comes after the fire. This is complicated when large quantities of corrosive combustion gases have developed from the fire, because these gases build corrosive acids (e.g. hydrochloric acid) when combined with extinguishing water. Such acids are finely dispersed well beyond the location of the fire throughout the entire building, causing damage to all metallic objects. Potential examples include: structural steel, metal constructions, electrical installations, electronics and IT systems.

Save lives

Impede fires

Minimise consequential
damage

These three requirements have been incorporated in the fire classification of the new EU Construction Products Regulation.

CE marking and declaration of performance

EU Construction Products Regulation

Power, control and communication cables that are permanently installed in structures fall under EU Regulation 305/2011 (Construction Products Regulation). Excluded from this: lift cables, cables inside machinery and cables for use in industrial plants.

The EU Construction Products Regulation defines the conditions for the CE marking and requires a declaration of performance of the manufacturer on the following essential product features derived from the protective goals: fire safety (flame propagation, heat development, smoke production, acid formation, flaming droplets) and the absence of harmful substances. In addition, the Construction Products Regulation specifies how conformity with the requirements is permanently ensured.

With the publication of the harmonised standard EN 50575:2014 in the Official Journal of the European Union, the requirement for implementation of the Construction Products Regulation has now been established for all market participants. This standard states the following: 'Power, control and communication cables, cables for general applications in construction works terms of fire behaviour requirements'. Effective 01 July 2016, a cable manufacturer must provide a CE marking on products that have been tested and certified by a notified body and issue a corresponding Declaration of Performance.

After expiry of the coexistence period, which is one year, the CE marking and creation of a Declaration of Performance are mandatory.

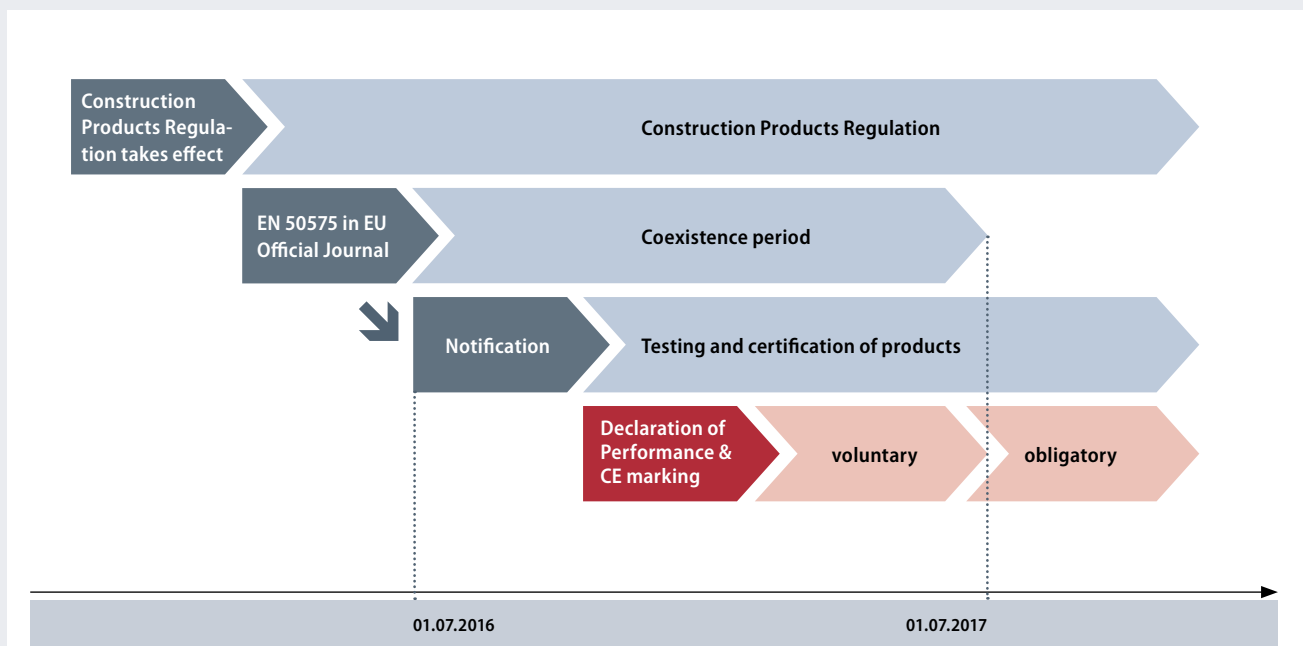

The Declaration of Performance certifies compliance with the fire classes defined below and is thus a requirement for use of the cable for the applications defined by the EU Member States.

Note: Cables with circuit and system integrity (resistance to fire) are handled separately in a different standard to be harmonised in the future. They are therefore not subject to current implementation of the Construction Products Regulation. Application of the Construction Products Regulation for these cables is not expected prior to 2017.

Fire classifications and proof of conformity

EU Construction Products Regulation

The classes of fire response are shown in the following table, with a classification of requirements ranging from A_{ca} (non-flammable) and B1_{ca} or B2_{ca} (very high) to C_{ca} (high), D_{ca} (moderate),

E_{ca} (low) and F_{ca} (no requirement). This classification from A to F applies in general to all construction products. The index 'ca' stands for cable.

Classes of fire behaviour of electrical cabins according to DIN EN 13501-6

		Classification						
Test method	Parameter	A _{ca}	B1 _{ca}	B2 _{ca}	C _{ca}	D _{ca}	E _{ca}	F _{ca}
EN ISO 1716	PCS (MJ/kg)	≤ 2.0	–	–	–	–	–	–
EN 60332-1	H (mm)	–	≤ 425	≤ 425	≤ 425	≤ 425	≤ 425	–
EN 50399	Flame source (kW)	–	30	20.5	20.5	20.5	–	–
EN 50399	FS (m)	–	≤ 1.75	≤ 1.5	≤ 2.0	–	–	–
EN 50399	THR (MJ)	–	≤ 10	≤ 15	≤ 30	≤ 70	–	–
EN 50399	max. HRR (kW)	–	≤ 20	≤ 30	≤ 60	≤ 400	–	–
EN 50399	FIGRA (W/s)	–	≤ 120	≤ 150	≤ 300	≤ 1300	–	–
		Additional classification						
EN 50399/EN 61034	Smoke development	–	s1, s1a, s1b, s2, s3	s1, s1a, s1b, s2, s3	s1, s1a, s1b, s2, s3	s1, s1a, s1b, s2, s3	no	no
EN 60754 -2	Corrosiveness	–	a1, a2, a3	a1, a2, a3	a1, a2, a3	a1, a2, a3	no	no
EN 50399	Burning droplets	–	d0, d1, d2	d0, d1, d2	d0, d1, d2	d0, d1, d2	no	no

H: Flame Spread, vertical flame propagation (mm)
FS: Flame Spread, vertical flame propagation (m)
PCS: Pouvoir Calorifique Supérieur, gross calorific value

THR: Total Heat Release (MJ)
HRR: Heat Release Rate, maximum heat release rate (kW)
FIGRA: Fire Growth Rate, index of heat release rate (W/s)

TSP: Total Smoke Production, (m³)
SPR: Smoke Production Rate, max. (m³/s)

Explanation

s1 = TSP ≤ 50 m³ and max. SPR ≤ 0.25 m³/s
s1a = **s1** and transmission value acc. to EN 61034-2 ≥ 80 %
s1b = **s1** and transmission value acc. to EN 61034-2 ≥ 60 % < 80 %
s2 = TSP ≤ 400 m³ and max. SPR ≤ 1.5 m³/s
s3 = neither s1 nor s2

d0 = no flaming droplets/particles
d1 = no flaming droplets/particles for longer than 10 s
d2 = neither d0 nor d1

EN 60754-2:
a1 = electrical conductivity < 2.5 μS/mm and pH value > 4.3
a2 = electrical conductivity < 10 μS/mm and pH value > 4.3
a3 = neither a1 nor a2. No data = no performance determined.

Conformity monitoring is also set out in detail in the Construction Products Regulation and defined by EN 50575.

The following is a simplified summary of the obligations for the notified approval body and the manufacturer:

Class of fire behaviour	A _{ca}	B1 _{ca}	B2 _{ca}	C _{ca}	D _{ca}	E _{ca}	F _{ca}
System of conformity monitoring	1+				3		4
Obligations of the notified body	Sample testing and recurring factory auditing with random sampling				Sample testing		–
Obligations of the manufacturer	Production monitoring				Production monitoring		–

Overview of fire testing

These are the goals when using safety cables.

1. >> **Save lives**
2. >> **Impede fires**
3. >> **Minimise consequential damage**

The fire test according to EN 50399 covers Goals 1 and 2 because reduced fire propagation, smoke and flaming droplets make an essential contribution to fire safety.

The cables (number used dependent on cable diameter) are mounted onto a ladder in a vertical tube furnace and a flame is applied to them for 20 minutes using an air gas burner (20 kW / 30 kW). The flue gases are collected with a defined air current (nominal value 8000 l/min) and conducted into an exhaust air duct in which the speed of the air current, the oxygen and CO₂ content, the light absorption and the temperature are measured. This allows the above values to be determined. As many parameters differ from those occurring in the test according to IEC 60332-3, the results cannot be transferred. In particular, the installation of the cable with the distance and elevated air current make the fire scenario more demanding than in IEC 60332-3.

The test according to EN 50399 clearly demonstrates the difference between a cable with high fire safety (below) and a cable of lower quality. The fire propagation, smoke and flaming droplets can be clearly seen (above).

Fire classes according to the Construction Products Regulation

Cables for energy, control and communication. The fire performance of power, control and communication cables for fixed installation in buildings is analysed and classified according to EU Regulation 305/2011. For this purpose, the heat release and the flame spread are measured via the above test method according to EN 50399 and evaluated in order to classify the cables according to the relevant fire class. The cables can also achieve additional classification according to the Construction Products Regulation if smoke production, flaming droplets and acidity are determined.

The test according to EN 50399 allows flame propagation, heat release, smoke production and flaming droplets/particles to be determined.



EN 50399

The majority of the parameters required for cables in the Construction Products Regulation are determined by means of the test according to EN 50399.

A strongly burning cable with increased smoke and flaming droplets/particles.



EN 50399

A cable that meets the requirements of B2_{cs}s1 d1 a1.



The 4 m high fire cabin according to EN 50399, in which the cables are installed vertically on a ladder.

Smoke production in the test according to EN 61034: this fire test was carried out with a heavily smoking cable.



EN 61034

Smoke production in the test according to EN 61034. This fire test was carried out on a cable that meets the requirements.



EN 61034

Flame test on individual cable according to EN 60332-1, the basic requirement.



EN 60332-1

Smoke production is subject to especially strict evaluation in the test according to EN 61034.

Reduced smoke generation is a key factor in meeting Objective 1 when evacuating buildings with a high density of people and difficult evacuation conditions. Evaluation of corrosiveness and acidity (EN 50267) is important not just in order to avoid the damage resulting from corrosion (Objective 3), but also to avoid their toxic effect on people attempting to escape in the event of a fire (Objective 2).

The flame test on a single cable according to EN 60332-1 provides the basis for less demanding requirements.

These objectives are met by the Construction Products Regulation in that the safety levels defined by the fire tests are applied in relation to the building in question. The German Electrical and Electronic Manufacturers' Association (ZVEI) has drafted a proposal for the effective application of these safety levels. This is presented below and on the following pages.



Corrosiveness is assessed in accordance with EN 50267 by means of a chemical analysis of the combustion gases.

Depending on the safety requirement in buildings, the ZVEI recommends the use of fire-resistant cables. The use of class B_{2ca} cables is effective in buildings with very high safety requirements, while the use of class C_{ca} cables makes sense in buildings with high safety requirements. A recommendation for the building classification according to the German Model Building Code (MBO) was also drafted on this basis. Finally, these recommendations are also being incorporated in new versions of installation requirements for energy and communications cabling (DIN EN 50174 Part 1-3, DIN VDE 0100-520 and DIN VDE 0100-420).

Cable type with Euroclass B2_{ca} s1a d1 a1

Overview of the areas of application

Recommendation of the ZVEI for the fire classes to be applied for cable under the Construction Products Regulation

Fire classes				Safety requirements in buildings
Flame propagation Heat development	Smoke development / density	Flaming droplets	Acid formation / corrosiveness	
A _{ca}	–	–	–	Very high
B1 _{ca}	–	–	–	Very high
B2 _{ca}	s1	d1	a1	Very high
C _{ca}	s1	d1	a1	High
D _{ca}	s2	d2	a1	Moderate
E _{ca}	–	–	–	Low
F _{ca}	–	–	–	None

Proposal of the ZVEI for building classification

Building classes according to the German Model Building Code				ZVEI proposal	
Class	Description			Minimum requirement	
				Building (except escape route)	Escape route
1	Free-standing buildings and free-standing buildings used for agricultural or forestry purposes	up to 7 m high	with a total surface area or no more than 400 m ²	E _{ca}	–
2	Building	up to 7 m high	with a total surface area or no more than 400 m ²	E _{ca}	–
3	Other buildings	up to 7 m high	–	E _{ca}	B2 _{ca} s1 d1 a1
4	Other buildings	up to 13 m high	up to n × 400 m ²	E _{ca}	B2 _{ca} s1 d1 a1
5	Other buildings including underground buildings	–	–	C _{ca} s1 d2 a1	B2 _{ca} s1 d1 a1

Special structures			ZVEI proposal	
S1	High-rise buildings	higher than 22 m	C _{ca} s1 d2 a1	B2 _{ca} s1 d1 a1
S2	Construction systems	higher than 30 m	C _{ca} s1 d2 a1	B2 _{ca} s1 d1 a1
S3	Building	more than 1600 m ² largest storey, excluding residential buildings and garages	C _{ca} s1 d2 a1	B2 _{ca} s1 d1 a1
S4	Retail buildings	larger than 800 m ²	C _{ca} s1 d2 a1	B2 _{ca} s1 d1 a1
S5	Office/administration	rooms larger than 400 m ²	C _{ca} s1 d2 a1	B2 _{ca} s1 d1 a1
S6	Building with rooms	individual rooms – use by more than 100 persons	C _{ca} s1 d2 a1	B2 _{ca} s1 d1 a1
S7	Assembly buildings	more than 200 persons	C _{ca} s1 d2 a1	B2 _{ca} s1 d1 a1
S8	Restaurants/hotels	more than 40 guests in buildings, more than 12 beds, amusement halls larger than 150 m ²	C _{ca} s1 d2 a1	B2 _{ca} s1 d1 a1
S9	Buildings with units for care or dependants	more than 6 persons, intensive care requirement	B2 _{ca} s1 d1 a1	B2 _{ca} s1 d1 a1
S10	Hospitals		B2 _{ca} s1 d1 a1	B2 _{ca} s1 d1 a1
S11	Other facilities for accommodation of persons also residential homes		C _{ca} s1 d2 a1	B2 _{ca} s1 d1 a1
S12	Day care facilities for children, disabled and elderly persons		B2 _{ca} s1 d1 a1	B2 _{ca} s1 d1 a1
S13	Schools, universities and similar facilities		C _{ca} s1 d2 a1	B2 _{ca} s1 d1 a1
S14	Correctional facilities / involuntary treatment		C _{ca} s1 d2 a1	B2 _{ca} s1 d1 a1
S16	Leisure / amusement parks		C _{ca} s1 d2 a1	B2 _{ca} s1 d1 a1
S18	Warehouse with top edge of loaded goods higher than 7.5 m		E _{ca}	B2 _{ca} s1 d1 a1
S19	Construction systems for storage of materials with an increased risk of fire		B2 _{ca} s1 d1 a1	B2 _{ca} s1 d1 a1

Additional specified structures	ZVEI proposal	
Industry	C _{ca} s1 d2 a1	B2 _{ca} s1 d1 a1
Server rooms	B2 _{ca} s1 d1 a1	B2 _{ca} s1 d1 a1
Road tunnels	B2 _{ca} s1 d1 a1	B2 _{ca} s1 d1 a1
Railway tunnels	B2 _{ca} s1 d1 a1	B2 _{ca} s1 d1 a1
Underground garages	C _{ca} s1 d2 a1	B2 _{ca} s1 d1 a1

On the safe side with LEONI



LEONI has been one of the world's leading providers of safety cables for many years. Whether infrastructure, energy, data or communication cables:

LEONI offers the best cable technology that is currently available for fire protection.

In addition to standard cables corresponding to the new fire classes D_{ca} and E_{ca}, LEONI also provides fire class B2_{ca} cables. Euroclass B2_{ca} s1 d1 a1 fire-resistant cables offer increased safety due to:

- **Reduced fire propagation**
- **Reduced heat development**
- **Low smoke density**
- **Low acid production**
- **Reduced droplet formation**

The quality of these cable products is assured by:

- **Conformity verification 1+**
- **Declaration of Performance**
- **CE mark**

Data cable colour code according to CPR classes

Increased safety for logistics, installation and building approval due to colour distinctions



For simple and safe installation in buildings with different fire protection requirements, LEONI MegaLine® data cables are distinguished according to different CPR classes by means of colour coding.

As well as increasing safety, this colour scheme benefits logistics experts and fitters.

- Cable according to CPR Class D_{ca} in "rape yellow"
- Cable according to CPR Class C_{ca} in "lime green"
- Cable according to CPR Class B2_{ca} in "yellow green"

Cable sheath in **rape yellow**

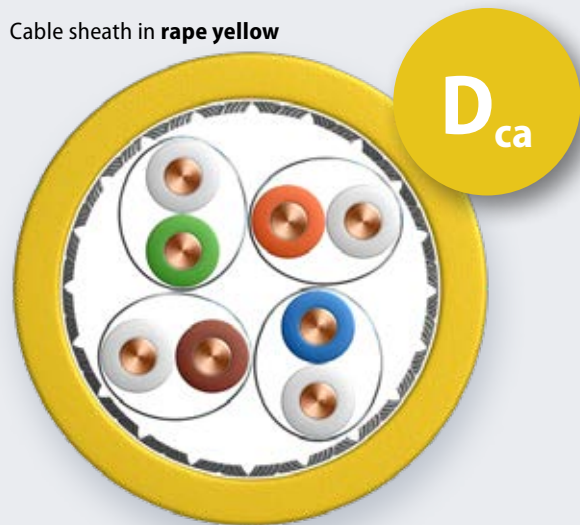

Cable sheath in **lime green**

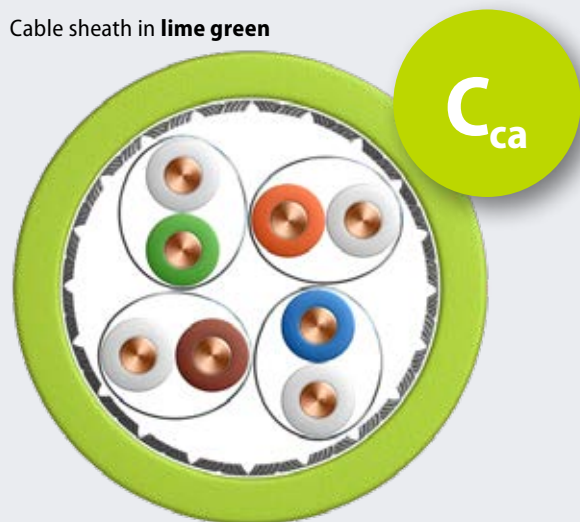

Cable sheath in **yellow green**

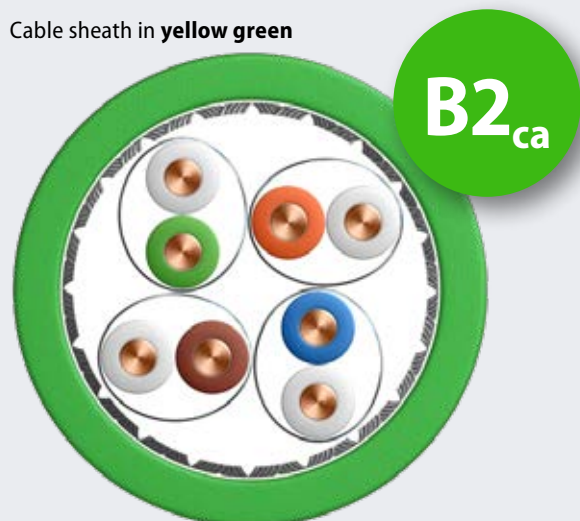

Type codes

MegaLine® copper data cable

MegaLine® F10-130 S/F H

Cabling class	
Class 7 _A +	G
Class F	F
Class E	E
Class D	D
Bandwidth acc. to standard (factor 100)	
2000 MHz	20
1200 MHz	12
1000 MHz	10
600 MHz	6
500 MHz	5
250 MHz	2
100 MHz	1
MegaLine® bandwidth (factor 10)	
1500 MHz	150
1300 MHz	130
1150 MHz	115
900 MHz	90
800 MHz	80
700 MHz	70
450 MHz	45
300 MHz	30
200 MHz	20
TP (Twisted Pair) design	
Overall shielding (copper braiding)/individual shield (foil)	S/F
Overall shielding (foil)/individual shielding (foil)	F/F
Unshielded/individual shielding (foil)	U/F
Overall shielding (copper braiding & foil)/unshielded	SF/U
Overall shielding (foil)/unshielded	F/U
Unshielded/unshielded	U/U
Sheath/armouring	
Halogen free, flame-retardant	H
PVC	Y
PE	2Y
PUR	11Y
Sheath	(L)2Y
Reinforced sheath for industrial applications	V
Oil-resistant	Ö
Steel wire braiding	Q

The type codes for the MegaLine® copper data cables are compatible in structure with the SPACE concept. This makes it easier to assign cables to the old and new cabling classes and the corresponding categories.

The type codes also provide:

- Specifications for the bandwidth in comparison with the standard
- Specifications for the design according to international standard
- Specifications for the sheath material used

Copper data cables: MegaLine® F10-130 S/F H

F	according to cable class F _A (1000 MHz)
10	Bandwidth according to standard: 1000 MHz
130	MegaLine bandwidth: 1300 MHz
S/F	in S/FTP design
H	with halogen-free outer sheath

Cable types

MegaLine® copper data cable

		Cable type	xx/xxx
Overall shielding			
Foil shielding	F		
Braided shielding	S		
Braiding and foil shielding	SF		
Individual shielding			
Unshielded	U		
Foil shielding	F		
Symmetrical element		P	

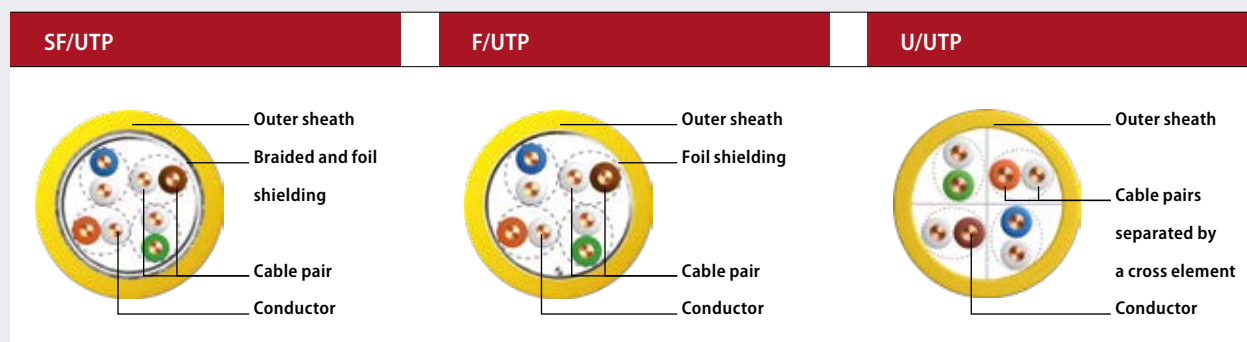
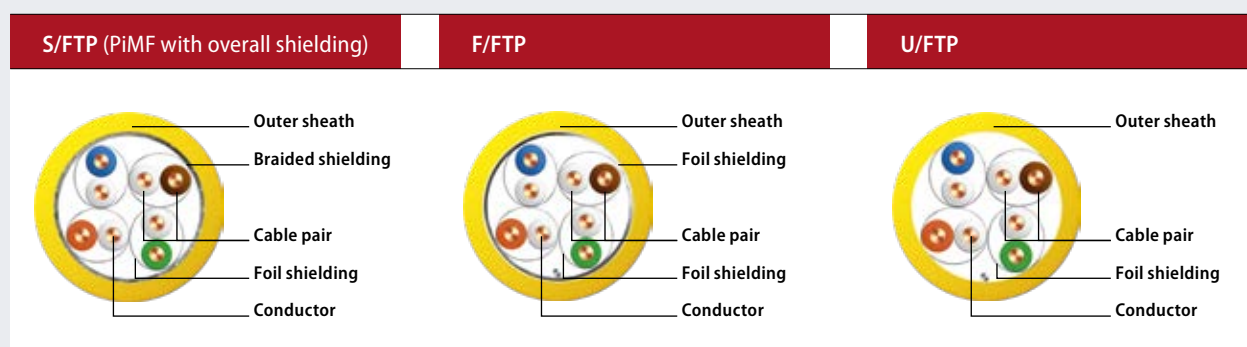

Cable type

There are a large number of different type designations. In the second edition ISO/IEC 11801, a standardisation was defined which unambiguously determines the elements of the design.

SF/UTP Cable with overall braided and foil shielding / with unshielded individual elements.

S/FTP Cable with overall braided shielding / foil-shielded individual elements.

PiMF Pair in metal foil (xx/FTP)

MegaLine® G20 S/F

Category 8.2



Types **KS-02YSCH 4x2x0.62 mm/~AWG 22/1 PIMF**
KS-02YSCH 2x(4x2x0,62 mm/~AWG 22/1 PIMF)

Advantages

- Data center cabling
- Better than Cat. 8.2
- bandwidth 2000 MHz
- excellent shielding characteristics
- VDE certified
- PVP-GHMT
- RoHS and REACh conformity

Construction for 4P

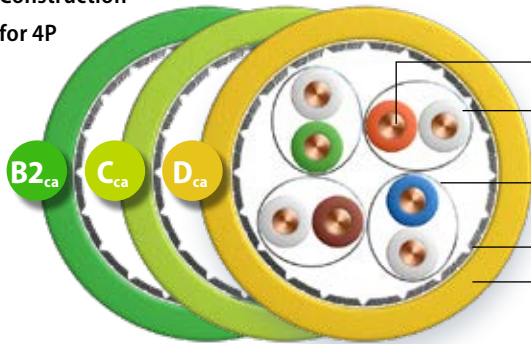

Conductor	Bare copper wire, 0.62 mm/~AWG 22/1
Insulation	Cellular PE, core Ø: nominal value 1.6 mm
Twisting element	Pair
Individual shielding	Aluminium bonded polyester foil, metal on the outside (PiMF)
Twisting	4 pairs
Overall shielding	Tinned copper braid
Outer sheath	Halogen-free, flame-retardant compound

Fire behaviour	
Flame retardancy	acc. to IEC 60332-3-24
Halogen free	acc. to IEC 60754-1/2
Smoke density	acc. to IEC 61034-1/2
Acid formation	acc. to EN 60754-2
Fire load (reference value)	0.74 MJ/m
EU Construction Products Regulation	acc. to EN 50575 / EN 50399

Performance	
Better than Category 8.2 acc. to IEC 61156-9, excellent NEXT, very low attenuation, excellent shielding characteristics (pairs and overall shielding), low skew, bandwidth (typical) 2000 MHz	

Applications	
Installation cable for use in structured cabling acc. to ISO/IEC 11801 and EN 50173 (3rd Edition) and data center cabling acc. to TR 11801-9901 11801-99-1.	
Ideal for all applications of Classes D to F _A and Class II, multimedia (TV, video, data, voice) > 40 GbE acc. to IEEE 802.3 bq, cable sharing, VoIP, PoE/PoE+	

Mechanical characteristics	
Bending radius during installation	8 x outer diameter (min.)
after installation	4 x outer diameter (min.)
Tensile strength (max.)	130 N
Crush strength	1000 N/100 mm
Impact strength (number of shocks)	10

Electromagnetic behaviour	
Coupling resistance at 10 MHz (nom.)	2 mΩ/m
Shield attenuation up to 1200 MHz (nom.)	80 dB
Coupling attenuation up to 1200 MHz (nom.)	90 dB
Separating class acc. to EN 50174-2	d

Security (fire behaviour)

S	1 IEC 60332-2-2	2 IEC-60332-1-2	3 IEC-60332-3-24	4 EFP Grade 1	5 EFP Grade 2
		E _{ca} /D _{ca}	E _{ca} /D _{ca}	C _{ca}	B2 _{ca}

Performance (cable class, bandwidth)

P	1 > Class E > 250 MHz	2 > Class E _A > 500 MHz	3 > Class F > 600 MHz	4 > Class F _A > 1000 MHz	5 > Class F _A + > 1200 MHz
----------	-----------------------------	--	-----------------------------	---	---

Application (Ethernet, TV)

A	1 > 100 MbE	2 > 1 GbE	3 up to 10 GbE	4 > 10 GbE	5 > 10 GbE TV
----------	----------------	--------------	-------------------	---------------	---------------------

Construction (conductor dimension, tensile strength)

C	1 AWG 27	2 AWG 26/25	3 AWG 24	4 AWG 23	5 AWG 22
----------	-------------	----------------	-------------	-------------	-------------

EMC (coupling attenuation)

E	1 > 40 dB	2 > 50 dB	3 > 60 dB	4 > 70 dB	5 > 80 dB
----------	--------------	--------------	--------------	--------------	--------------

Electrical characteristics (HF) at 20 °C

Frequency MHz	Attenuation dB/50 m		NEXT dB		PS-NEXT dB		ACR dB at 50 m		PS-ACR dB at 50 m		EL-FEXT dB at 50 m		PS-ELFEXT dB at 50 m		RL dB	
	typ.	Cat. 8.2 max.*	typ.	Cat. 8.2 min.*	typ.	Cat. 8.2 min.*	typ.	Cat. 8.2 min.*	typ.	Cat. 8.2 min.*	typ.	Cat. 8.2 min.*	typ.	Cat. 8.2 min.*	typ.	Cat. 8.2 min.*
10	2.4	2.9	100	78	97	75	97.6	75.1	94.6	72.1	90	78	87	75	32.3	25
100	8.6	9.3	100	75.4	97	72.4	91.4	66.1	88.4	63.1	90	60.6	87	57.6	36.2	22.5
250	13.7	14.7	100	69.5	97	66.5	86.3	54.8	83.3	51.8	84	52.6	81	49.6	34.8	20.1
500	18.9	21.4	100	64.9	97	61.9	81.1	43.5	78.1	40.5	79	46.6	76	43.6	31.8	17.3
600	22	23.6	100	63.7	97	60.7	78	40.2	75	37.2	78	45	75	42	28.5	17.3
800	25.6	27.5	95	61.9	92	58.9	69.4	34.4	66.4	31.4	71	42.5	68	39.5	25.3	16.1
1000	28.9	31	92	60.4	89	57.4	63.1	29.4	60.1	26.4	62	40.6	59	37.6	22.2	15.2
1200	31.6	34.2	88	59.2	85	56.2	56.4	25	53.4	22	60	39	57	36	20.2	14.7
1500	35.2	38.6	77	57.8	74	54.8	40.8	19.2	37.8	16.2	53	37.1	50	34.1	19.2	14
1600	36.6	40	75	57.3	72	54.3	37.8	17.3	34.8	14.3	50	36.5	47	33.5	18.4	13.8
1700	38.1	41.4	75	56.9	72	53.9	36.9	15.5	33.9	12.5	45	36	42	33	17.1	13.6
1800	39.5	42.7	75	56.6	72	53.6	35.5	13.9	32.5	10.9	42	35.5	39	32.5	16.3	13.4
1900	41.1	44	75	56.2	71	53.2	33.9	12.2	30.9	9.2	40	35	37	32	15.6	13.3
2000	43.5	45.3	75	55.9	72	52.9	31.5	10.7	28.5	7.7	40	34.6	37	31.6	15.1	13.1

* IEC 61156-9 (2016) If IO-FEXT is min. 90 dB to 1000 MHz and min. 80 dB to 2000 MHz, EL-FEXT is fulfilled by design.

Electrical characteristics (LF) at 20 °C

Direct current resistance	max.	68 Ω/km
Insulation resistance	min.	5 GΩ x km
Mutual capacitance	approx.	43 pF/m
Capacitive coupling (e)	approx.	1000 pF/km
Signal tempo (c)	approx.	0.76
Propagation delay	approx.	440 ns/100 m
Skew at 100 MHz	approx.	12 ns/100 m
Charact. impedance	at 100 MHz	100 ± 5 Ω
Testing voltage U _{eff}		1000 V
Operating voltage	max.	125 V

Thermal properties

For fixed installation	-20 °C to +60 °C
For mobile operation	0 °C to +50 °C

Chemical characteristics

Free of hazardous substances acc. to RoHS 2011/65/EU

Cable printing

LEONI MegaLine G20 S/F 4P H SPACE Code "xxxxx" "CPR Class"
"DoP no." "VDE mark" Made in Germany "Batch number"
"Metre marking"

Colour code

WH/BU, WH/OG, WH/GN, WH/BN

Certificates and approvals

Quality mark with production control:

<VDE>, GHMT PVP

Link performance: LEONI MegaLine® systems
and other commonly available connector systems

Test certificates: according to DIN 55350-18-4.2.1 or EN 10204

Compliant with LVD (2014/35/EU): 

Compliant with Construction Products Regulation
(EU/305/2011): 

Dimension	Outer Ø approx.	Weight approx.	Copper no.*	CPR class	DoP no.	Sheath colour	Order no.
	mm	kg/km	kg/km				
4P	8.1	68	38	D _{ca} s2 d2 a1	CDESK0000007	● Rape yellow	LKD 7KS8 0020 xxxx
2 x 4P	8.6 x 17.5	162	90	D _{ca} s2 d2 a1	CDESK0000008	● Rape yellow	LKD 7KS8 0022 xxxx
4P	8.6	68	38	C _{ca} s1 d1 a1	CDESK0000034	● Lime green	LKD 7KS8 C020 xxxx
4P	8.6	68	38	B2 _{ca} s1a d1 a1	CDESK0000010	● Yellow green	LKD 7KS8 B020 xxxx

Packaging: xxxx

Standard length: 0100 = 1000 m 0050 = 500 m 0000 = general

* see page 17: Definition of copper no.

MegaLine® G20 S/F Mini

Category 8.2

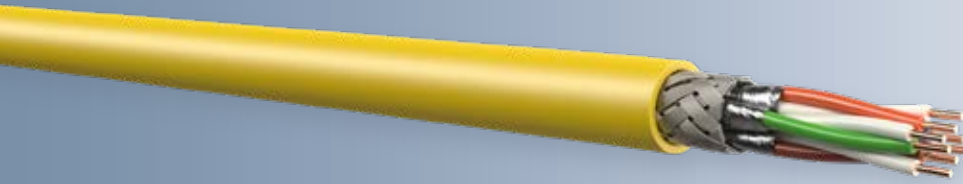

TypeKS-02YSCH 4x2xAWG26/1 PIMF

Advantages

- Better than Cat. 8.2
- Data center cabling
- bandwidth 2000 MHz
- excellent shielding characteristics
- VDE certified
- RoHS and REACh conformity

Construction for 4P

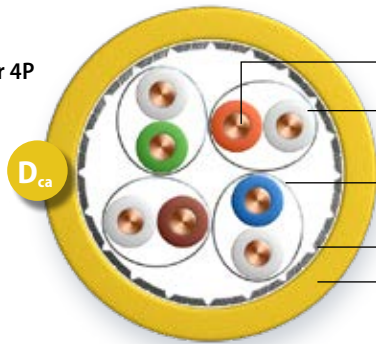

Conductor	Bare copper wire, AWG 26/1
Insulation	Cellular PE, core-diameter: max. 1.05 mm
Twisting element	Pair
Individual shielding	Aluminium bonded polyester foil, metal on the outside (PiMF)
Twisting	4 pairs
Overall shielding	Tinned copper braid
Outer sheath	halogen-free, flame-retardant compound

Fire behaviour

Flame retardancy	acc. to IEC 60332-1-2
Halogen free	acc. to IEC 60754-1/2
Smoke density	acc. to IEC 61034-1/2
Fire load (reference value)	0.38 MJ/m
EU Construction Products Regulation	acc. to EN 50575 / EN 50399

Performance

Better than Cat. 8.2 acc. to IEC 61156-10, excellent NEXT, very low attenuation, excellent shielding characteristics (pairs and overall shielding), low skew, bandwidth (typical) 2000 MHz

Applications

Connection cable and patch cord for use in structured cabling acc. to ISO/IEC 11801 and EN 50173 (3rd Edition) and data center cabling acc. to TR 11801-9901. Ideal for all applications of Classes D to F_x and Class II, multimedia (TV, video, data voice) 25/40 GbE acc. to IEEE 802.3 bq, cable sharing, VoIP, PoE/PoE+

Mechanical characteristics

Bending radius	during installation	8 x outer diameter (min.)
	after installation	4 x outer diameter (min.)
Tensile strength (max.)		60 N

Electromagnetic behaviour

Coupling resistance at 10 MHz (nom.)	5 mΩ/m
Shield attenuation up to 1000 MHz (nom.)	60 dB
Coupling attenuation up to 1000 MHz (nom.)	85 dB
Separating class acc. to EN 50174-2	d

Security (fire behaviour)

S	1 IEC 60332-2-2	2 IEC-60332-1-2 E _{ca} /D _{ca}	3 IEC-60332-3-24 E _{ca} /D _{ca}	4 EFP Grade 1 C _{ca}	5 EFP Grade 2 B2 _{ca}
---	--------------------	--	---	-------------------------------------	--------------------------------------

Performance (cable class, bandwidth)

P	1 > Class E > 250 MHz	2 > Class E _x > 500 MHz	3 > Class F > 600 MHz	4 > Class F _x > 1000 MHz	5 > Class F _x + > 1200 MHz
---	-----------------------------	--	-----------------------------	---	---

Application (Ethernet, TV)

A	1 > 100 MbE	2 > 1 GbE	3 up to 10 GbE	4 > 10 GbE	5 > 10 GbE TV
---	----------------	--------------	-------------------	---------------	---------------------

Construction (conductor dimension, tensile strength)

C	1 AWG 27	2 AWG 26/25	3 AWG 24	4 AWG 23	5 AWG 22
---	-------------	----------------	-------------	-------------	-------------

EMC (coupling attenuation)

E	1 > 40 dB	2 > 50 dB	3 > 60 dB	4 > 70 dB	5 > 80 dB
---	--------------	--------------	--------------	--------------	--------------

Electrical characteristics (HF) at 20 °C

Frequency MHz	Attenuation dB/30 m		NEXT dB		PS-NEXT dB		ACR dB at 30 m		PS-ACR dB at 30 m		EL-FEXT dB at 30 m		PS-ELFEXT dB at 30 m		RL dB	
	typ.	Cat. 8.2 max.*	typ.	Cat. 8.2 min.*	typ.	Cat. 8.2 min.*	typ.	Cat. 8.2 min.*	typ.	Cat. 8.2 min.*	typ.	Cat. 8.2 min.*	typ.	Cat. 8.2 min.*	typ.	Cat. 8.2 min.*
10	1.8	2.6	100	90.4	97	87.4	98.2	87.8	95.2	84.8	120	80.8	117	77.8	26	25.0
100	6.6	8.3	100	75.4	97	72.4	93.4	67.1	90.4	64.1	106	60.8	103	57.8	30	22.2
250	10.6	13.4	100	69.4	97	66.4	89.4	56.1	86.4	53.1	102	52.8	99	49.8	29	19.4
500	15.5	19.2	95	64.9	92	61.9	79.5	45.7	76.5	42.7	92	46.8	89	43.8	28	17.3
600	16.9	21.2	93	63.7	90	60.7	76.2	42.5	73.2	39.5	89	45.2	86	42.2	25	16.8
1000	22.4	27.9	75	60.4	72	57.4	52.3	32.5	49.3	29.5	82	40.8	79	37.8	23	15.2
1200	24.2	30.8	72	59.2	69	56.2	47.7	28.4	44.7	25.4	80	39.2	77	36.2	22	14.7
1500	27.0	34.7	72	57.8	69	54.8	44.6	23.0	41.6	20.0	76	37.3	73	34.3	21	14.0
1600	28.2	36.0	72	57.3	69	54.3	43.4	21.3	40.4	18.3	74	36.7	71	33.7	21	13.8
1700	29.6	37.2	72	56.9	69	53.9	42.0	19.7	39.0	16.7	73	36.2	70	33.2	20	13.6
1800	30.2	38.4	64	56.6	61	53.6	33.6	18.2	30.6	15.2	72	35.7	69	32.7	20	13.4
1900	31.4	39.6	64	56.2	61	53.2	32.4	16.6	29.4	13.6	70	35.2	67	32.2	19	13.3
2000	32.5	40.7	62	55.9	59	52.9	29.5	15.2	26.5	12.2	68	34.8	65	31.8	14	13.1

* IEC 61156-10 (2016 draft) If IO-FEXT is min. 90 dB to 1000 MHz and min. 80 dB to 2000 MHz, EL-FEXT is fulfilled by design.

Electrical characteristics (NF) at 20 °C

Direct current resistance	max.	145 Ω/km
Insulation resistance	min.	5 GΩ x km
Mutual capacitance	approx.	49 pF/m
Signal tempo (c)	approx.	0.78
Propagation delay	approx.	490 ns/100 m
Skew at 100 MHz	approx.	5 ns/100 m
Charact. impedance	at 100 MHz	100 ± 5 Ω
Testing voltage U _{eff}		1000 V
Operating voltage	max.	125 V

Thermal properties

For fixed installation	-20 °C to +60 °C
For mobile operation	0 °C to +50 °C

Chemical characteristics

Free of hazardous substances acc. to RoHS 2011/65/EU

Cable printing

LEONI MegaLine G20 S/F 4P H SPACE Code "xxxxx" "DoP no."
"VDE mark" Made in Germany "Batch number"
"Metre marking"

Colour code

WH/BU, WH/OG, WH/GN, WH/BN

Certificates and approvals

Quality mark with production control: <VDE>

Link performance: LEONI MegaLine® systems
and other commonly available connector systems

Test certificates: according to DIN 55350-18-4.2.1 or EN 10204

Compliant with LVD (2014/35/EU): 

Dimension	Outer Ø approx.	Weight approx.	Copper no.*	CPR class	DoP no.	Sheath colour	Order no.
	mm	kg/km	kg/km				
4P	6.0	40	23.5	D _{ca} s2 d2 a1	CDESK0000030	● Rape yellow	LKD 7KS8 0023 xxxx

Packaging: xxxx

Standard length: 0100 = 1000 m 0050 = 500 m 0000 = general

* see page 17: Definition of copper no.

MegaLine® G12-150 S/F

Category 7_A+

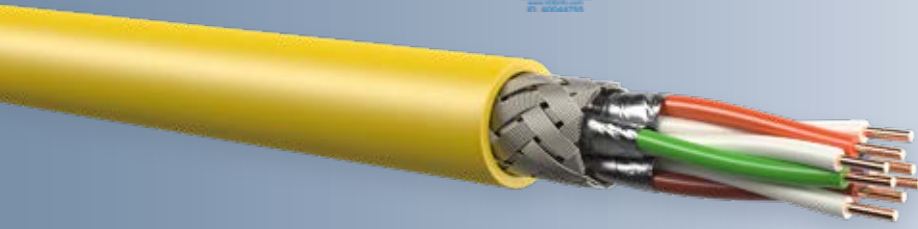

Types **KS-02YSCH 4x2xAWG 22/1 PIMF**
KS-02YSCH 2x(4x2xAWG 22/1 PIMF)

Advantages

- Better than Category 7_A+
- bandwidth 1500 MHz
- excellent shielding characteristics
- VDE certified
- PVP-GHMT
- RoHS and REACH conformity

Construction for 4P

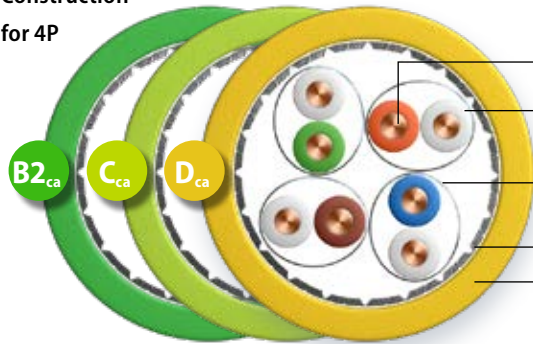

Conductor	Bare copper wire, AWG 22/1
Insulation	Cellular PE, core Ø: nominal value 1.6 mm
Twisting element	Pair
Individual shielding	Aluminium bonded polyester foil, metal on the outside (PiMF)
Twisting	4 pairs
Overall shielding	Tinned copper braid
Outer sheath	Halogen-free, flame-retardant compound

Fire behaviour	
Flame retardancy	acc. to IEC 60332-3-24
Halogen free	acc. to IEC 60754-1/2
Smoke density	acc. to IEC 61034-1/2
Acid formation	acc. to EN 60754-2
Fire load (reference value)	0.74 MJ/m (Sx), 1.5 MJ/m (Dx)
EU Construction Products Regulation	acc. to EN 50575 / EN 50399

Performance	
Better than Category 7, acc. to EN 50288 and IEC 61156, excellent NEXT, low attenuation, excellent shielding characteristics (pairs and overall shielding), low skew, bandwidth (typical) 1500 MHz	

Applications	
Installation cable for use in structured cabling acc. to ISO/IEC 11801 and EN 50173 (3rd Edition). Ideal for all applications of Classes D to F _A , multimedia (TV, video, data, voice) > 10 GbE acc. to IEEE 802.3 an, cable sharing, VoIP, PoE/PoE+.	

Mechanical characteristics	
Bending radius during installation	8 x outer diameter (min.)
after installation	4 x outer diameter (min.)
Tensile strength (max.)	130 N (Sx), 260 N (Dx)
Crush strength	1000 N/100 mm
Impact strength (number of shocks)	10

Electromagnetic behaviour	
Coupling resistance at 10 MHz (nom.)	2 mΩ/m
Shield attenuation up to 1200 MHz (nom.)	80 dB
Coupling attenuation up to 1200 MHz (nom.)	90 dB
Separating class acc. to EN 50174-2	d

Security (fire behaviour)

S	1 IEC 60332-2-2	2 IEC-60332-1-2	3 IEC-60332-3-24	4 EFP Grade 1	5 EFP Grade 2
		E _{ca} /D _{ca}	E _{ca} /D _{ca}	C _{ca}	B2 _{ca}

Performance (class, bandwidth)

P	1 > Class E > 250 MHz	2 > Class E _A > 500 MHz	3 > Class F > 600 MHz	4 > Class F _A > 1000 MHz	5 > Class F _A + > 1200 MHz
----------	-----------------------------	--	-----------------------------	---	---

Application (Ethernet, TV)

A	1 > 100 MbE	2 > 1 GbE	3 up to 10 GbE	4 > 10 GbE	5 > 10 GbE TV
----------	----------------	--------------	-------------------	---------------	------------------

Construction (conductor dimension, tensile strength)

C	1 AWG 27	2 AWG 26/25	3 AWG 24	4 AWG 23	5 AWG 22
----------	-------------	----------------	-------------	-------------	-------------

EMC (coupling attenuation)

E	1 > 40 dB	2 > 50 dB	3 > 60 dB	4 > 70 dB	5 > 80 dB
----------	--------------	--------------	--------------	--------------	--------------

Electrical characteristics (HF) at 20 °C

Frequency MHz	Attenuation dB/100 m		NEXT dB		PS-NEXT dB		ACR dB at 100 m		PS-ACR dB at 100 m		EL-FEXT dB at 100 m		PS-ELFEXT dB at 100 m		RL dB	
	typ.	Cat. 7 _A + max.	typ.	Cat. 7 _A + min.*	typ.	Cat. 7 _A + min.*	typ.	Cat. 7 _A + min.*	typ.	Cat. 7 _A + min.*	typ.	Cat. 7 _A + min.*	typ.	Cat. 7 _A + min.*	typ.	Cat. 7 _A + min.*
1	1.6	1.9	110	80	107	77	108	78	105	75	109	80	106	77	26.1	23
10	4.2	5.4	110	78	107	75	106	72	103	69	109	74	106	71	32.3	25
100	14.4	17.5	110	76	107	73	96	58	93	55	93	54	90	51	36.2	20.1
200	21.5	25.3	110	72	107	69	88	47	85	46	86	48	83	45	35.5	18
250	24.5	28.5	105	70	102	67	81	42	78	39	83	46	80	43	34.8	17.3
500	34	41.8	105	65.5	102	62.5	71	24	68	21	70	40	67	37	31.8	17.3
600	37.7	46.3	100	64.3	97	61.3	62	18	59	15	64	38.4	61	35.4	28.5	17.3
800	44.5	54.5	95	62.5	92	59.5	50	8	47	5	58	35.9	55	32.9	25.3	16.1
900	48.1	58.4	95	61.7	92	58.7	47	3	44	0	54	34.9	51	31.9	23.8	15.5
1000	49	62	92	61	89	58	43	-1.1	40	-4	49	34	46	31	22.2	15.1
1200	54.9	69	88	59.8	85	56.8	34	-9	31	-12	40	32.4	37	29.4	20.2	14.3
1300	57	-	81	-	78	-	24	-	21	-	35	-	32	-	18.3	-
1400	58.1	-	74	-	71	-	16	-	13	-	30	-	27	-	16.3	-
1500	62	-	73	-	70	-	11	-	8	-	25	-	22	-	12.3	-

* EN 50288-9-1(2013)/IEC 61156-5 (2009)/IEC 61156-7(2003). If IO FEXT is min. 90 dB, EL-FEXT is fulfilled by design.

Electrical characteristics (LF) at 20 °C

Direct current resistance	max.	57.1 Ω/km
Insulation resistance	min.	5 GΩ x km
Mutual capacitance	approx.	42 pF/m
Capacitive coupling (e)	approx.	1000 pF/km
Signal tempo (c)	approx.	0.77
Propagation delay	approx.	420 ns/100 m
Skew at 100 MHz	approx.	3 ns/100 m
Charact. impedance	at 100 MHz	100 ± 5 Ω
Testing voltage U _{eff}		1000 V
Operating voltage	max.	125 V

Thermal properties

For fixed installation	-20 °C to +60 °C
For mobile operation	0 °C to +50 °C

Chemical characteristics

Free of hazardous substances acc. to RoHS 2011/65/EU

Cable printing for 4P

LEONI MegaLine G12-150 S/F 4P H SPACE Code "xxxxx"
 "CPR Class" "DoP no." "VDE mark" Made in Germany
 "Batch number" "Metre marking"

Colour code

WH/BU, WH/OG, WH/GN, WH/BN

Certificates and approvals

Quality mark with production control:

<VDE>, GHMT PVP

Link performance: LEONI MegaLine® systems







and other commonly available connector systems

Test certificates: according to DIN 55350-18-4.2.1 or EN 10204

Compliant with LVD (2014/35/EU): 

Compliant with Construction Products Regulation

(EU/305/2011): 

Dimension	Outer Ø approx.	Weight approx.	Copper no.*	CPR class	DoP no.	Sheath colour	Order no.
	mm	kg/km	kg/km				
4P	8.6	80	48	D _{ca} s2 d2 a1	CDESK0000007	 Rape yellow	LKD 7KS8 0001 xxxx
2 x 4P	8.6 x 17.5	162	96	D _{ca} s2 d2 a1	CDESK0000008	 Rape yellow	LKD 7KS8 0010 xxxx
4P	8.6	80	48	C _{ca} s1 d1 a1	CDESK00000034	 Lime green	LKD 7KS8 C001 xxxx
2 x 4P	8.6 x 17.5	162	96	C _{ca} s1 d1 a1	CDESK00000040	 Lime green	LKD 7KS8 C010 xxxx
4P	8.6	80	48	B2ca s1a d1 a1	CDESK00000010	 Yellow green	LKD 7KS8 B001 xxxx
2 x 4P	8.6 x 17.5	162	96	B2ca s1a d1 a1	CDESK00000033	 Yellow green	LKD 7KS8 B010 xxxx

Packaging: xxxx

Standard length: 0100 = 1000 m 0050 = 500 m 0000 = general

* see page 17: Definition of copper no.

MegaLine® F10-130 S/F

Category 7_A

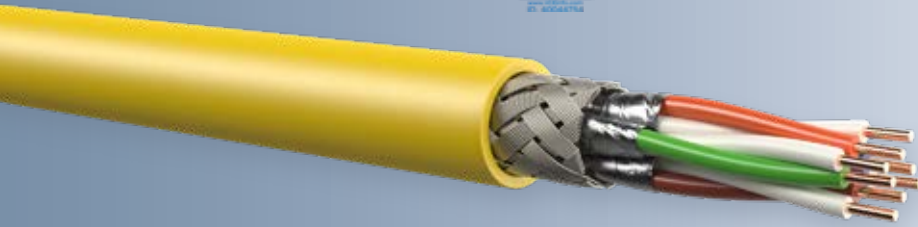

Types **KS-02YSCH 4x2xAWG 22/1 PIMF**
KS-02YSCH 2x(4x2xAWG 22/1 PIMF)

Advantages

- Better than Category 7_A
- bandwidth 1300 MHz
- excellent shielding characteristics
- VDE certified
- PVP-GHMT
- RoHS and REACH conformity

Construction for 4P

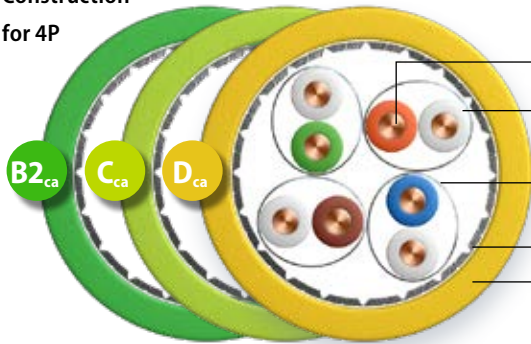

Conductor	Bare copper wire, AWG 22/1
Insulation	Cellular PE, core Ø: nominal value 1.6 mm
Twisting element	Pair
Individual shielding	Aluminium bonded polyester foil, metal on the outside (PiMF)
Twisting	4 pairs
Overall shielding	Tinned copper braid
Outer sheath	Halogen-free, flame-retardant compound

Fire behaviour

Flame retardancy	acc. to IEC 60332-3-24
Halogen free	acc. to IEC 60754-1/2
Smoke density	acc. to IEC 61034-1/2
Acid formation	acc. to EN 60754-2
Fire load (reference value)	0.70 MJ/m (Sx), 1.4 MJ/m (Dx)
EU Construction Products Regulation	acc. to EN 50575 / EN 50399

Performance

Better than Category 7, acc. to EN 50288 and IEC 61156
 excellent NEXT, low attenuation, excellent shielding characteristics (pairs and overall shielding), low skew, bandwidth (typical) 1300 MHz

Applications

Installation cable for use in structured cabling acc. to ISO/IEC 11801 and EN 50173 (3rd Edition).
 Ideal for all applications of Classes D to F_A, multimedia (TV, video, data, voice) > 10 GbE acc. to IEEE 802.3 an, cable sharing, VoIP, PoE/PoE+.

Mechanical characteristics

Bending radius during installation	8 x outer diameter (min.)
after installation	4 x outer diameter (min.)
Tensile strength (max.)	130 N (Sx), 260 N (Dx)
Crush strength	1000 N/100 mm
Impact strength (number of shocks)	10

Electromagnetic behaviour

Coupling resistance at 10 MHz (nom.)	5 mΩ/m
Shield attenuation up to 1000 MHz (nom.)	70 dB
Coupling attenuation up to 1000 MHz (nom.)	85 dB
Separating class acc. to EN 50174-2	d

Security (fire behaviour)

S	1 IEC 60332-2-2	2 IEC-60332-1-2 E_{ca}/D_{ca}	3 IEC-60332-3-24 E_{ca}/D_{ca}	4 EFP Grade 1 C_{ca}	5 EFP Grade 2 B2_{ca}
----------	--------------------	--	---	---	--

Performance (cable class, bandwidth)

P	1 > Class E > 250 MHz	2 > Class E _A > 500 MHz	3 > Class F > 600 MHz	4 > Class F _A > 1000 MHz	5 > Class F _A + > 1200 MHz
----------	-----------------------------	--	-----------------------------	---	---

Application (ethernet, TV)

A	1 > 100 MbE	2 > 1 GbE	3 up to 10 GbE	4 > 10 GbE	5 > 10 GbE TV
----------	----------------	--------------	-------------------	---------------	------------------

Construction (conductor dimension, tensile strength)

C	1 AWG 27	2 AWG 26/25	3 AWG 24	4 AWG 23	5 AWG 22
----------	-------------	----------------	-------------	-------------	-------------

EMC (coupling attenuation)

E	1 > 40 dB	2 > 50 dB	3 > 60 dB	4 > 70 dB	5 > 80 dB
----------	--------------	--------------	--------------	--------------	--------------

Electrical characteristics (HF) at 20 °C

Frequency MHz	Attenuation dB/100 m		NEXT dB		PS-NEXT dB		ACR dB at 100 m		PS-ACR dB at 100 m		ACR-F dB at 100 m		PSACR-F dB at 100 m		RL dB	
	typ.	Cat. 7 _A max.*	typ.	Cat. 7 _A min.*	typ.	Cat. 7 _A min.*	typ.	Cat. 7 _A min.*	typ.	Cat. 7 _A min.*	typ.	Cat. 7 _A min.*	typ.	Cat. 7 _A min.*	typ.	Cat. 7 _A min.*
1	1.7	2.1	105	78	102	75	104	75.9	101	72.9	105	78	102	75	27.1	20
10	4.5	5.8	105	78	102	75	101	72.2	98	69.2	108	75.3	105	72.3	35.2	25
100	15.4	18.5	105	75.4	102	72.4	90	56.9	87	53.9	93	55.3	90	52.3	38.9	20.1
200	22.9	26.5	105	70.9	102	67.9	83	44.4	80	41.4	85	49.3	82	46.3	36.6	18
250	26	29.7	105	69.4	102	66.4	79	39.7	76	36.7	82	47.3	79	44.3	35.3	17.3
500	35.9	42.8	100	64.9	97	61.9	64	22.2	61	19.2	70	41.3	67	38.3	29.4	17.3
600	40.4	47.1	95	63.7	92	60.7	55	16.6	52	13.6	63	39.7	60	36.7	26.6	17.3
700	44.6	51.1	95	62.7	92	59.7	50	11.6	47	8.6	60	38.4	57	35.4	25.8	16.6
800	47.7	54.9	93	61.9	90	58.9	45	6.9	42	3.9	57	37.2	54	34.2	25	16.1
900	51.6	58.5	90	61.1	87	58.1	38	2.6	35	-0.4	53	36.2	50	33.2	23.6	15.5
1000	54.8	61.9	88	60.4	85	57.4	33	-1.5	30	-4.5	48	35.3	45	32.3	22.3	15.1
1100	56.9	-	87	-	84	-	30	-	27	-	44	-	41	-	21.4	-
1300	61.4	-	80	-	77	-	21	-	18	-	39	-	36	-	18.3	-

* EN 50288-9-1 (2013)/IEC 61156-5 (2009). As a result of the configuration of several individual elements, up to 3% higher attenuation values and frequency-selective reflections can occur.

Electrical characteristics (LF) at 20 °C

Direct current resistance	max.	57.1 Ω/km
Insulation resistance	min.	5 GΩ x km
Mutual capacitance	approx.	40 pF/m
Capacitive coupling (e)	approx.	1100 pF/km
Signal tempo (c)	approx.	0.77
Propagation delay	approx.	420 ns/100 m
Skew at 100 MHz	approx.	5 ns/100 m
Charact. impedance	at 100 MHz	100 ± 5 Ω
Testing voltage U _{eff}		1000 V
Operating voltage	max.	125 V

Thermal properties

For fixed installation	-20 °C to +60 °C
For mobile operation	0 °C to +50 °C

Chemical characteristics

Free of hazardous substances acc. to RoHS 2011/65/EU

Cable printing for 4 P

LEONI MegaLine F10-130 S/F 4P H SPACE Code "xxxxx"
 "CPR Class" "DoP no." "VDE mark" Made in Germany
 "Batch number" "Metre marking"

Colour code

WH/BU, WH/OG, WH/GN, WH/BN

Certificates and approvals

Quality mark with production control:

<VDE>, GHMT PVP

Link performance: LEONI MegaLine® systems

and other commonly available connector systems

Test certificates: according to DIN 55350-18-4.2.1 or EN 10204

Compliant with LVD (2014/35/EU): **CE**

Compliant with Construction Products Regulation

(EU/305/2011): **CE**

Dimension	Outer Ø approx.	Weight approx.	Copper no.	CPR class	DoP no.	Sheath colour	Order no.
	mm	kg/km	kg/km				
4P	8.6	80	45	D _{ca} s2 d2 a1	CDESK0000007	● Rape yellow	LKD 7KS7 0001 xxxx
2 x 4P	8.6 x 17.5	162	90	D _{ca} s2 d2 a1	CDESK0000008	● Rape yellow	LKD 7KS7 0002 xxxx
4P	8.6	80	45	C _{ca} s1 d1 a1	CDESK0000034	● Lime green	LKD 7KS7 C001 xxxx
2 x 4P	8.6 x 17.5	162	90	C _{ca} s1 d1 a1	CDESK0000040	● Lime green	LKD 7KS7 C002 xxxx
4P	8.6	80	45	B2 _{ca} s1a d1 a1	CDESK0000010	● Yellow green	LKD 7KS7 B001 xxxx
2 x 4P	8.6 x 17.5	162	90	B2 _{ca} s1a d1 a1	CDESK0000033	● Yellow green	LKD 7KS7 B002 xxxx

Packaging: xxxx

Standard length: 0100 = 1000 m 0050 = 500 m 0000 = general

* see page 17: Definition of copper no.

MegaLine® F10-125 S/F

Category 7_A

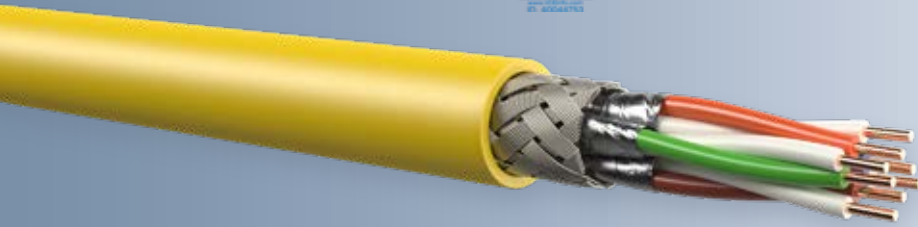

Types **KS-02YSCH 4x2x0.62 mm/~AWG 22/1 PIMF**
KS-02YSCH 2x(4x2x0,62 mm/~AWG 22/1 PIMF)

Advantages

- Better than Category 7_A
- bandwidth 1300 MHz
- excellent shielding characteristics
- VDE certified
- PVP-GHMT
- RoHS and REACH conformity

Construction for 4P

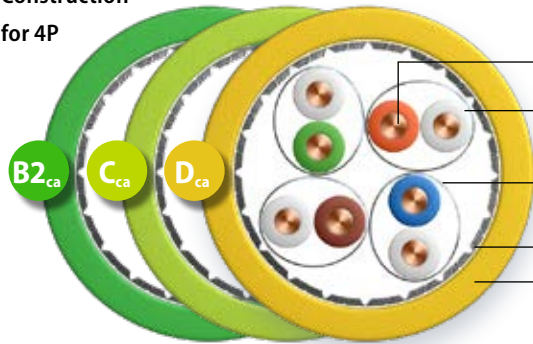

Conductor	Bare copper wire, 0.62 mm/~AWG 22/1
Insulation	Cellular PE, core Ø: nominal value 1.5 mm
Twisting element	Pair
Individual shielding	Aluminium bonded polyester foil, metal on the outside (PiMF)
Twisting	4 pairs
Overall shielding	Tinned copper braid
Outer sheath	Halogen-free, flame-retardant compound

Fire behaviour

Flame retardancy	acc. to IEC 60332-3-24
Halogen free	acc. to IEC 60754-1/2
Smoke density	acc. to IEC 61034-1/2
Fire load (reference value)	0.65 MJ/m (Sx), 1.33 MJ/m (Dx)
Acid formation	acc. to EN 60754-2
EU Construction Products Regulation	acc. to EN 50575 / EN 50399

Performance

Better than Category 7, acc. to EN 50288 and IEC 61156
 excellent NEXT, low attenuation, excellent shielding characteristics
 (pairs and overall shielding), low skew, bandwidth (typical) 1300 MHz

Applications

Installation cable for use in structured cabling acc. to ISO/IEC 11801 and EN 50173 (3rd Edition).
 Ideal for all applications of Classes D to F_A, **multimedia** (video, data, voice)
 > 10 GbE acc. to IEEE 802.3 an, cable sharing, VoIP, PoE/PoE+.

Mechanical characteristics

Bending radius	during installation 8 x outer diameter (min.) after installation 4 x outer diameter (min.)
Tensile strength (max.)	110 N (Sx), 220 N (Dx)
Crush strength	1000 N/100 mm
Impact strength (number of shocks)	10

Electromagnetic behaviour

Coupling resistance at 10 MHz (nom.)	5 mΩ/m
Shield attenuation up to 1000 MHz (nom.)	70 dB
Coupling attenuation up to 1000 MHz (nom.)	85 dB
Separating class acc. to EN 50174-2	d

Security (fire behaviour)

S	1 IEC 60332-2-2	2 IEC-60332-1-2 E _{ca} /D _{ca}	3 IEC-60332-3-24 E _{ca} /D _{ca}	4 EFP Grade 1 C _{ca}	5 EFP Grade 2 B2 _{ca}
----------	--------------------	--	---	-------------------------------------	--------------------------------------

Performance (cable class, bandwidth)

P	1 > Class E > 250 MHz	2 > Class E _A > 500 MHz	3 > Class F > 600 MHz	4 > Class F _A > 1000 MHz	5 > Class F _A + > 1200 MHz
----------	-----------------------------	--	-----------------------------	---	---

Application (ethernet, TV)

A	1 > 100 MbE	2 > 1 GbE	3 up to 10 GbE	4 > 10 GbE	5 > 10 GbE TV
----------	----------------	--------------	-------------------	---------------	---------------------

Construction (conductor dimension, tensile strength)

C	1 AWG 27	2 AWG 26/25	3 AWG 24	4 AWG 23	5 AWG 22
----------	-------------	----------------	-------------	-------------	-------------

EMC (coupling attenuation)

E	1 > 40 dB	2 > 50 dB	3 > 60 dB	4 > 70 dB	5 > 80 dB
----------	--------------	--------------	--------------	--------------	--------------

Electrical characteristics (HF) at 20 °C

Frequency MHz	Attenuation dB/100 m		NEXT dB		PS-NEXT dB		ACR dB at 100 m		PS-ACR dB at 100 m		EL-FEXT dB at 100 m		PS-ELFEXT dB at 100 m		RL dB	
	typ.	Cat. 7 _A max.*	typ.	Cat. 7 _A min.*	typ.	Cat. 7 _A min.*	typ.	Cat. 7 _A min.*	typ.	Cat. 7 _A min.*	typ.	Cat. 7 _A min.*	typ.	Cat. 7 _A min.*	typ.	Cat. 7 _A min.*
1	1.8	2.1	105	78	102	75	104	75.9	101	72.9	105	78	102	75	27.1	20
10	4.7	5.8	105	78	102	75	101	72.2	98	69.2	108	75.3	105	72.3	35.2	25
100	15.9	18.5	105	75.4	102	72.4	89	56.9	86	53.9	93	55.3	90	52.3	38.9	20.1
200	23.5	26.5	105	70.9	102	67.9	81	44.4	78	41.4	85	49.3	82	46.3	36.6	18
250	26.6	29.7	105	69.4	102	66.4	79	39.7	76	36.7	82	47.3	79	44.3	35.3	17.3
500	37	42.8	100	64.9	97	61.9	63	22.2	60	19.2	70	41.3	67	38.3	29.4	17.3
600	41.8	47.1	95	63.7	92	60.7	53	16.6	50	13.6	63	39.7	60	36.7	26.6	17.3
700	45.2	51.1	95	62.7	92	59.7	50	11.6	47	8.6	60	38.4	57	35.4	25.8	16.6
800	48	54.9	93	61.9	90	58.9	45	6.9	42	3.9	57	37.2	54	34.2	25	16.1
900	52.3	58.5	90	61.1	87	58.1	38	2.6	35	-0.4	53	36.2	50	33.2	23.6	15.5
1000	55.2	61.9	88	60.4	85	57.4	33	-1.5	30	-4.5	48	35.3	45	32.3	22.3	15.1
1100	57.6	-	87	-	84	-	29	-	26	-	44	-	41	-	21.4	-
1300	64.9	-	80	-	77	-	15	-	13	-	39	-	36	-	18.3	-

* EN 50288-9-1(2013)/IEC 61156-5 (2009)

Electrical characteristics at 20 °C

Direct current resistance	max.	65 Ω/km
Insulation resistance	min.	5 GΩ x km
Mutual capacitance	approx.	42 pF/m
Capacitive coupling (e)	approx.	1100 pF/km
Signal tempo (c)	approx.	0.80
Propagation delay	approx.	420 ns/100 m
Skew at 100 MHz	approx.	5 ns/100 m
Charact. impedance	at 100 MHz	100 ± 5 Ω
Testing voltage U _{eff}		1000 V
Operating voltage	max.	125 V

Thermal properties

For fixed installation	-20 °C to +60 °C
For mobile operation	0 °C to +50 °C

Chemical characteristics

Free of hazardous substances acc. to RoHS 2011/65/EU

Cable printing for 4 P

LEONI MegaLine F10-125 S/F 4P H SPACE Code "xxxxx"
 "CPR Class" "DoP no." "VDE mark" Made in Germany
 "Batch number" "Metre marking"

Colour code

WH/BU, WH/OG, WH/GN, WH/BN

Certificates and approvals

Quality mark with production control:

<VDE>, GHMT PVP

Link performance: LEONI MegaLine® systems





and other commonly available connector systems

Test certificates: according to DIN 55350-18-4.2.1 or EN 10204

Compliant with LVD (2014/35/EU): 

Compliant with Construction Products Regulation

(EU/305/2011): 

Dimension	Outer Ø approx.	Weight approx.	Copper no.*	CPR class	DoP no.	Sheath colour	Order no.
	mm	kg/km	kg/km				
4P	8.1	68	38	D _{ca} s2 d2 a1	CDESK0000007	 Rape yellow	LKD 7KS7 0253 xxxx
2 x 4P	8.0 x 16.4	141	76	D _{ca} s2 d2 a1	CDESK0000008	 Rape yellow	LKD 7KS7 0293 xxxx
4P	8.6	68	38	C _{ca} s1 d1 a1	CDESK0000034	 Lime green	LKD 7KS7 C253 xxxx
4P	8.6	68	38	B2 _{ca} s1a d1 a1	CDESK0000010	 Yellow green	LKD 7KS7 B253 xxxx

Packaging: xxxx

Standard length: 0100 = 1000 m 0050 = 500 m 0000 = general

* see page 17: Definition of copper no.

MegaLine® F10-115 S/F

Category 7_A

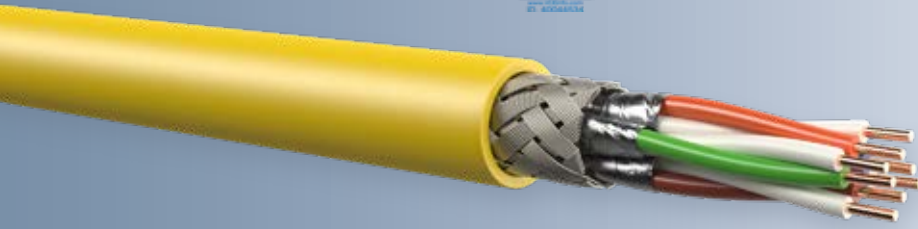

Types **KS-02YSCH 4x2xAWG 23/1 PIMF**
KS-02YSCH 2x(4x2xAWG 23/1 PIMF)

Advantages

- Better than Category 7_A
- bandwidth 1200 MHz
- excellent shielding characteristics
- VDE certified
- PVP-GHMT
- RoHS and REACh conformity

Construction for 4P

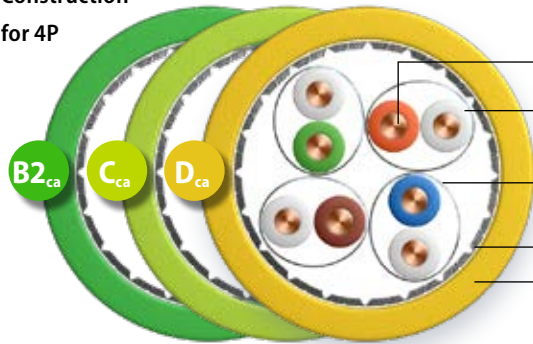

Conductor	Bare copper wire, AWG 23/1
Insulation	Cellular PE, core Ø: nominal value 1.4 mm
Twisting element	Pair
Individual shielding	Aluminium bonded polyester foil, metal on the outside (PiMF)
Twisting	4 pairs
Overall shielding	Tinned copper braid
Outer sheath	halogen-free, flame-retardant compound

Fire behaviour	
Flame retardancy	acc. to IEC 60332-3-24
Halogen free	acc. to IEC 60754-1/2
Smoke density	acc. to IEC 61034-1/2
Acid formation	acc. to EN 60754-2
Fire load (reference value)	0.60 MJ/m (Sx), 1.2 MJ/m (Dx)
EU Construction Products Regulation	acc. to EN 50575 / EN 50399

Performance	
Better than Category 7, acc. to EN 50288 and IEC 61156, excellent NEXT, low attenuation, excellent shielding characteristics (pairs and overall shielding), low skew, bandwidth (typical) 1200 MHz	

Applications	
Installation cable for use in structured cabling acc. to ISO/IEC 11801 and EN 50173 (3rd Edition).	
Ideal for all applications of Classes D to F _A , multimedia (video, data, voice) > 10 GbE acc. to IEEE 802.3 an, cable sharing, VoIP, PoE/PoE+.	

Mechanical characteristics	
Bending radius during installation	8 x outer diameter (min.)
after installation	4 x outer diameter (min.)
Tensile strength (max.)	110 N (Sx), 220 N (Dx)
	440 n (4-fold), 650 N (6-fold)
Crush strength	1000 N/100 mm
Impact strength (number of shocks)	10

Electromagnetic behaviour	
Coupling resistance at 10 MHz (nom.)	5 mΩ/m
Shield attenuation up to 1000 MHz (nom.)	70 dB
Coupling attenuation up to 1000 MHz (nom.)	85 dB
Separating class acc. to EN 50174-2	d

Security (fire behaviour)

S	1 IEC 60332-2-2	2 IEC-60332-1-2 E_{ca}/D_{ca}	3 IEC-60332-3-24 E_{ca}/D_{ca}	4 EFP Grade 1 C_{ca}	5 EFP Grade 2 B2_{ca}
----------	--------------------	--	---	---	--

Performance (cable class, bandwidth)

P	1 > Class E > 250 MHz	2 > Class E _A > 500 MHz	3 > Class F > 600 MHz	4 > Class F _A > 1000 MHz	5 > Class F _A + > 1200 MHz
----------	-----------------------------	--	-----------------------------	---	---

Application (ethernet, TV)

A	1 > 100 MbE	2 > 1 GbE	3 up to 10 GbE	4 > 10 GbE	5 > 10 GbE TV
----------	----------------	--------------	-------------------	---------------	---------------------

Construction (conductor dimension, tensile strength)

C	1 AWG 27	2 AWG 26/25	3 AWG 24	4 AWG 23	5 AWG 22
----------	-------------	----------------	-------------	-------------	-------------

EMC (coupling attenuation)

E	1 > 40 dB	2 > 50 dB	3 > 60 dB	4 > 70 dB	5 > 80 dB
----------	--------------	--------------	--------------	--------------	--------------

Electrical characteristics (HF) at 20 °C

Frequency MHz	Attenuation dB/100 m		NEXT dB		PS-NEXT dB		ACR dB at 100 m		PS-ACR dB at 100 m		EL-FEXT dB at 100 m		PS-ELFEXT dB at 100 m		RL dB	
	typ.	Cat. 7 _A max.*	typ.	Cat. 7 _A min.*	typ.	Cat. 7 _A min.*	typ.	Cat. 7 _A min.*	typ.	Cat. 7 _A min.*	typ.	Cat. 7 _A min.*	typ.	Cat. 7 _A min.*	typ.	Cat. 7 _A min.*
1	1.9	2.1	105	78	102	75	104	75.9	101	72.9	98	78	95	75	26.6	20
10	4.8	5.8	105	78	102	75	101	72.2	98	69.2	103	75.3	100	72.3	35.3	25
100	16.3	18.5	105	75.4	102	72.4	89	56.9	86	53.9	89	55.3	86	52.3	39.6	20.1
200	24.3	26.5	105	70.9	102	67.9	81	44.4	78	41.4	82	49.3	79	46.3	36	18
250	27.5	29.7	105	69.4	102	66.4	78	39.7	75	36.7	79	47.3	76	44.3	34	17.3
500	37.9	42.8	100	64.9	97	61.9	62	22.2	59	19.2	67	41.3	64	38.3	29	17.3
600	42.4	47.1	95	63.7	92	60.7	53	16.6	50	13.6	60	39.7	57	36.7	25.4	17.3
700	47.2	51.1	95	62.7	92	59.7	48	11.6	45	8.6	57	38.4	54	35.4	24.6	16.6
800	50.3	54.9	93	61.9	90	58.9	43	6.9	40	3.9	53	37.2	50	34.2	23.5	16.1
900	54.6	58.5	90	61.1	87	58.1	35	2.6	32	-0.4	49	36.2	46	33.2	22.6	15.5
1000	58	61.9	88	60.4	85	57.4	30	-1.5	27	-4.5	44	35.3	41	32.3	21.5	15.1
1150	61.9	-	86	-	83	-	25	-	22	-	39	-	36	-	20.6	-
1200	64	-	85	-	82	-	21	-	18	-	35	-	32	-	19	-

* EN 50288-9-1 (2013)/IEC 61156-5 (2009)

Electrical characteristics (LF) at 20 °C

Direct current resistance	max.	75 Ω/km
Insulation resistance	min.	5 GΩ x km
Mutual capacitance	approx.	42 pF/m
Capacitive coupling (e)	approx.	1100 pF/km
Signal tempo (c)	approx.	0.78
Propagation delay	approx.	420 ns/100 m
Skew at 100 MHz	approx.	5 ns/100 m
Charact. impedance	at 100 MHz	100 ± 5 Ω
Testing voltage U _{eff}		1000 V
Operating voltage	max.	125 V

Thermal properties

For fixed installation	-20 °C to +60 °C
For mobile operation	0 °C to +50 °C

Chemical characteristics

Free of hazardous substances acc. to RoHS 2011/65/EU

Cable printing for 4 P

LEONI MegaLine F10-115 S/F 4P H SPACE Code "xxxxx"
 "CPR Class" "DoP no." "VDE mark" Made in Germany
 "Batch number" "Metre marking"

Colour code

WH/BU, WH/OG, WH/GN, WH/BN

Certificates and approvals

Quality mark with production control:

<VDE>, GHMT PVP

Link performance: LEONI MegaLine® systems

and other commonly available connector systems

Test certificates: according to DIN 55350-18-4.2.1 or EN 10204

Compliant with LVD (2014/35/EU): **CE**

Compliant with Construction Products Regulation

(EU/305/2011): **CE**

Dimension	Outer Ø approx.	Weight approx.	Copper no.*	CPR class	DoP no.	Sheath colour	Order no.
	mm	kg/km	kg/km				
4P	7.5	67	37	D _{ca} s2 d2 a1	CDESK0000005	● Rape yellow	LKD 7KS7 0008 xxxx
2 x 4P	7.5 x 15.2	136	74	D _{ca} s2 d2 a1	CDESK0000006	● Rape yellow	LKD 7KS7 0009 xxxx
4P	7.4	57	35	C _{ca} s1 d1 a1	CDESK0000035	● Lime green	LKD 7KS7 C008 xxxx
4P	7.4	57	35	B2 _{ca} s1a d1 a1	CDESK0000009	● Yellow green	LKD 7KS7 B008 xxxx

Packaging: xxxx

Standard length: 0100 = 1000 m 0050 = 500 m 0000 = general

* see page 17: Definition of copper no.

MegaLine® F6-90 S/F

Category 7

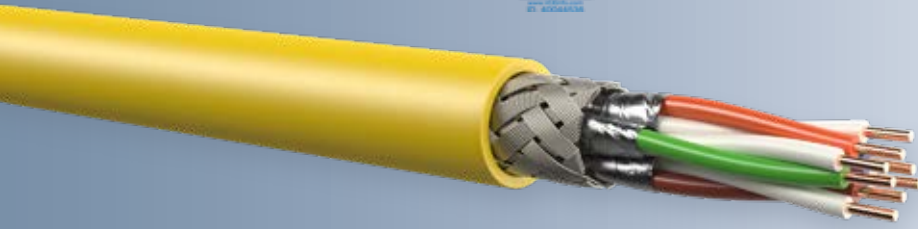

Types **KS-02YSCH 4x2xAWG 23/1 PIMF**
KS-02YSCH 2x(4x2xAWG 23/1 PIMF)

Advantages

- Better than Category 7
- bandwidth 1000 MHz
- excellent shielding characteristics
- VDE certified
- PVP-GHMT
- RoHS and REACH conformity

Construction for 4P

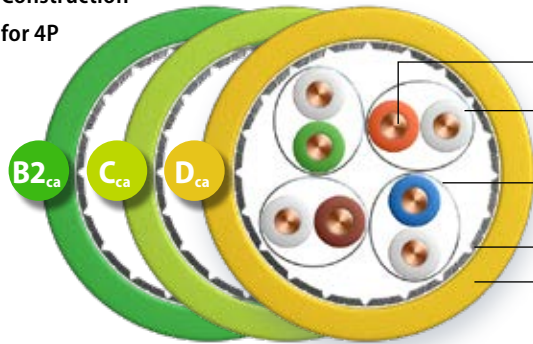

Conductor	Bare copper wire, AWG 23/1
Insulation	Cellular PE, core Ø: nominal value 1.4 mm
Twisting element	Pair
Individual shielding	Aluminium bonded polyester foil, metal on the outside (PiMF)
Twisting	4 pairs
Overall shielding	Tinned copper braid
Outer sheath	halogen-free, flame-retardant compound

Fire behaviour	
Flame retardancy	acc. to IEC 60332-3-24
Halogen free	acc. to IEC 60754-1/2
Smoke density	acc. to IEC 61034-1/2
Acid formation	acc. to EN 60754-2
Fire load (reference value)	0.60 MJ/m (Sx), 1.2 MJ/m (Dx)
EU Construction Products Regulation	acc. to EN 50575 / EN 50399

Performance	
Better than Category 7 acc. to EN 50288 and IEC 61156	
excellent NEXT, excellent shielding characteristics (shielding in pairs and overall shielding), low skew, bandwidth (typical) 1000 MHz	

Applications	
Installation cable for use in structured cabling acc. to ISO/IEC 11801 and EN 50173 (3rd Edition).	
Ideal for all applications of Classes D to F, multimedia (video, data, voice) > 10 GbE acc. to IEEE 802.3 an, cable sharing, VoIP, PoE/PoE+.	

Mechanical characteristics	
Bending radius during installation	8 x outer diameter (min.)
after installation	4 x outer diameter (min.)
Tensile strength (max.)	110 N (Sx), 220 N (Dx), 400 N (4-fold), 600 N (6-fold), 850 N (8-fold)
Crush strength	1000 N/100 mm
Impact strength (number of shocks)	10

Electromagnetic behaviour	
Coupling resistance at 10 MHz (nom.)	5 mΩ/m
Shield attenuation up to 1000 MHz (nom.)	70 dB
Coupling attenuation up to 1000 MHz (nom.)	85 dB
Separating class acc. to EN 50174-2	d

Security (fire behaviour)

	1	2	3	4	5
	IEC 60332-2-2	IEC-60332-1-2	IEC-60332-3-24	EFP Grade 1	EFP Grade 2
S		E _{ca} /D _{ca}	E _{ca} /D _{ca}	C _{ca}	B2 _{ca}

Performance (cable class, bandwidth)

	1	2	3	4	5
	> Class E	> Class E _A	> Class F	> Class F _A	> Class F _A +
	> 250 MHz	> 500 MHz	> 600 MHz	> 1000 MHz	> 1200 MHz
P					

Application (ethernet, TV)

	1	2	3	4	5
	> 100 MbE	> 1 GbE	up to 10 GbE	> 10 GbE	> 10 GbE TV
A					

Construction (conductor dimension, tensile strength)

	1	2	3	4	5
	AWG 27	AWG 26/25	AWG 24	AWG 23	AWG 22
C					

EMC (coupling attenuation)

	1	2	3	4	5
	> 40 dB	> 50 dB	> 60 dB	> 70 dB	> 80 dB
E					

Electrical characteristics (HF) at 20 °C

Frequency MHz	Attenuation dB/100 m		NEXT dB		PS-NEXT dB		ACR dB at 100 m		PS-ACR dB at 100 m		EL-FEXT dB at 100 m		PS-ELFEXT dB at 100 m		RL dB	
	typ.	Cat. 7 max.*	typ.	Cat. 7 min.*	typ.	Cat. 7 min.*	typ.	Cat. 7 min.*	typ.	Cat. 7 min.*	typ.	Cat. 7 min.*	typ.	Cat. 7 min.*	typ.	Cat. 7 min.*
1	1.9	2	102	80	99	77	101	78	98	75	109	80	106	77	25.4	23
10	4.8	5.7	102	80	99	77	98	74	95	71	108	74	105	71	31.1	25
100	16.4	18.5	102	72	99	69	86	54	83	51	93	54	90	51	33.2	20.1
200	24.5	26.8	102	68	99	65	78	41	75	38	85	48	82	45	33.2	18
250	27.8	30.2	102	66	99	63	75	36	72	33	82	46	79	43	33.4	17.3
450	36.1	41.6	97	63	94	60	61	21	58	18	72	41	69	38	31.4	17.3
500	38.2	44.1	97	62	94	59	59	18	56	15	68	40	65	37	30.5	17.3
600	42.9	48.9	92	61	89	58	49	12	46	9	62	38	59	35	27.6	17.3
700	47.7	–	92	–	89	–	44	–	41	–	59	–	56	–	26.2	–
800	50.8	–	90	–	87	–	39	–	36	–	56	–	53	–	23.9	–
900	55.1	–	85	–	82	–	30	–	27	–	52	–	49	–	21.7	–
1000	58.0	–	80	–	77	–	22	–	19	–	42	–	39	–	18.0	–

* EN 50288-4-1 (2014)/IEC 61156-5 (2009)

Electrical characteristics (LF) at 20 °C

Direct current resistance	max.	75 Ω/km
Insulation resistance	min.	5 GΩ x km
Mutual capacitance	approx.	42 pF/m
Capacitive coupling (e)	approx.	1100 pF/km
Signal tempo (c)	approx.	0.80
Propagation delay	approx.	420 ns/100 m
Skew at 100 MHz	approx.	5 ns/100 m
Charact. impedance	at 100 MHz	100 ± 5 Ω
Testing voltage U _{eff}		1000 V
Operating voltage	max.	125 V

Thermal properties

For fixed installation	–20 °C to +60 °C
For mobile operation	0 °C to +50 °C

Chemical characteristics

Free of hazardous substances acc. to RoHS 2011/65/EU

Cable printing for 4P

LEONI MegaLine F6-90 S/F 4P H SPACE Code "xxxxx"
 "CPR Class" "DoP no." "VDE mark" Made in Germany
 "Batch number" "Metre marking"

Colour code

WH/BU, WH/OG, WH/GN, WH/BN

Certificates and approvals

Quality mark with production control:

<VDE>, GHMT PVP

Link performance: LEONI MegaLine® systems

and other commonly available connector systems

Test certificates: according to DIN 55350-18-4.2.1 or EN 10204

Compliant with LVD (2014/35/EU): **CE**

Compliant with Construction Products Regulation

(EU/305/2011): **CE**

Dimension	Outer Ø approx.	Weight approx.	Copper no.*	CPR class	DoP no.	Sheath colour	Order no.
	mm	kg/km	kg/km				
4P	7.4	57	35	D _{ca} s2 d2 a1	CDESK0000005	● Rape yellow	LKD 7KS7 0010 xxxx
2 x 4P	7.5 x 15.2	117	70	D _{ca} s2 d2 a1	CDESK0000006	● Rape yellow	LKD 7KS7 0011 xxxx
4P	7.4	57	35	C _{ca} s1 d1 a1	CDESK0000035	● Lime green	LKD 7KS7 C010 xxxx
2 x 4P	7.5 x 15.2	117	70	C _{ca} s1 d1 a1	CDESK0000039	● Lime green	LKD 7KS7 C011 xxxx
4P	7.4	57	35	B2 _{ca} s1a d1 a1	CDESK0000009	● Yellow green	LKD 7KS7 B010 xxxx
2 x 4P	7.5 x 15.2	117	70	B2 _{ca} s1a d1 a1	CDESK0000032	● Yellow green	LKD 7KS7 B011 xxxx

Packaging: xxxx

Standard length: 0100 = 1000 m 0050 = 500 m 0000 = general

* see page 17: Definition of copper no.

MegaLine® F6-90 S/F CI

Category 7



Type KS-02YSCH CI 4x2xAWG 23/1 PIMF

Construction for 4P

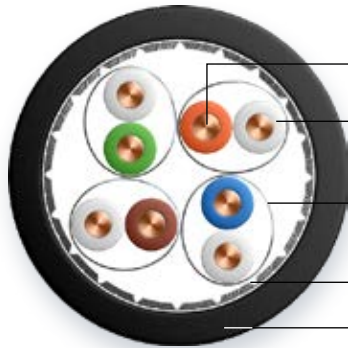

Conductor	Bare copper wire, AWG 23/1
Insulation	Cellular PE, core Ø: nominal value 1.4 mm
Twisting element	Pair
Taping	Fire protection foil
Individual shielding	Aluminium bonded polyester foil, metal on the outside (PiMF)
Twisting	4 pairs
Overall shielding	Tinned copper braid, opt. coverage 65 %
Taping	Fire protection foil
Outer sheath	halogen-free, flame-retardant compound

Fire behaviour

Flame retardancy	acc. to IEC 60332-3-24/22
Halogen free	acc. to IEC 60754-1/2
Smoke density	acc. to IEC 61034-1/2
Fire load (reference value)	1.05 MJ/m

Performance

Better than Category 7 acc. to EN 50288 and IEC 61156, excellent NEXT, excellent shielding characteristics (pairs and overall shielding), low skew, circuit integrity acc. to IEC 60331-23 (FE90) and system integrity based on EN 50200 (PH120) and EN 50289-4-16 (Cat. 6_s), bandwidth (typical) 900 MHz

Applications

Installation cable for use in structured cabling acc. to ISO/IEC 11801 and EN 50173 (3rd Edition).

Ideal for all applications of Classes D to F, multimedia (video, data, voice) > 10 GbE acc. to IEEE 802.3 an, cable sharing, VoIP, PoE/PoE+ and for IT wiring systems with circuit and system integrity.

Mechanical characteristics

Bending radius during installation	8 x outer diameter (min.)
after installation	4 x outer diameter (min.)
Tensile strength (max.)	110 N
Crush strength	2000 N/100 mm
Impact strength (number of shocks)	20

Electromagnetic behaviour

Coupling resistance at 10 MHz (nom.)	5 mΩ/m
Shield attenuation up to 1000 MHz (nom.)	70 dB
Coupling attenuation up to 1000 MHz (nom.)	85 dB
Separating class acc. to EN 50174-2	d



Advantages

- Better than Category 7
- bandwidth 900 MHz
- excellent shielding characteristics
- RoHS and REACh conformity

System integrity on exposure to fire for at least.

90 minutes

Security (fire behaviour)

S	1	2	3	4	5
	IEC 60332-2-2	IEC-60332-1-2	IEC-60332-3-24	EFP Grade 1	EFP Grade 2

Performance (cable class, bandwidth)

P	1	2	3	4	5
	> Class E	> Class E _A	> Class F	> Class F _A	> Class F _{A+}
	> 250 MHz	> 500 MHz	> 600 MHz	> 1000 MHz	> 1200 MHz

Application (ethernet, TV)

I	1	2	3	4	5
	> 100 MbE	> 1 GbE	up to 10 GbE	> 10 GbE	> 10 GbE TV

Construction (conductor dimension, tensile strength)

C	1	2	3	4	5
	AWG 27	AWG 26/25	AWG 24	AWG 23	AWG 22

EMC (coupling attenuation)

E	1	2	3	4	5
	> 40 dB	> 50 dB	> 60 dB	> 70 dB	> 80 dB

Electrical characteristics (HF) at 20 °C

Frequency MHz	Attenuation dB/100 m		NEXT dB		PS-NEXT dB		ACR dB at 100 m		PS-ACR dB at 100 m		EL-FEXT dB at 100 m		PS-ELFEXT dB at 100 m		RL dB	
	typ.	Cat. 7 max.*	typ.	Cat. 7 min.*	typ.	Cat. 7 min.*	typ.	Cat. 7 min.*	typ.	Cat. 7 min.*	typ.	Cat. 7 min.*	typ.	Cat. 7 min.*	typ.	Cat. 7 min.*
1	1.9	2	102	80	99	77	101	78	98	75	109	80	106	77	25.4	23
10	4.8	5.7	102	80	99	77	98	74	95	71	108	74	105	71	31.1	25
100	16.4	18.5	102	72	99	69	86	54	83	51	93	54	90	51	33.2	21.1
200	24.5	26.8	102	68	99	65	78	41	75	38	85	48	82	45	33.2	18
250	27.8	30.2	102	66	99	63	75	36	72	33	82	46	79	43	33.4	17.3
450	36.1	41.6	97	63	94	60	61	21	58	18	72	41	69	38	31.4	17.3
500	38.2	44.1	97	62	94	59	59	18	56	15	68	40	65	37	30.5	17.3
600	42.9	48.9	92	61	89	58	49	12	46	9	62	38	59	35	27.6	17.3
700	47.7	–	92	–	89	–	44	–	41	–	59	–	56	–	26.2	–
800	50.8	–	90	–	87	–	39	–	36	–	56	–	53	–	23.9	–
900	55.1	–	85	–	82	–	30	–	27	–	52	–	49	–	21.7	–

* EN 50288-4-1 (2014)/IEC 61156-5 (2009)

Electrical characteristics (LF) at 20 °C

Direct current resistance	max.	75 Ω/km
Insulation resistance	min.	5 GΩ x km
Mutual capacitance	approx.	42 pF/m
Capacitive coupling (e)	approx.	1100 pF/km
Signal tempo (c)	approx.	0.80
Propagation delay	approx.	420 ns/100 m
Skew at 100 MHz	approx.	5 ns/100 m
Charact. impedance	at 100 MHz	100 ± 5 Ω
Testing voltage U _{eff}		1000 V
Operating voltage	max.	125 V

Thermal properties

For fixed installation	-25 °C to +75 °C
For mobile operation	-10 °C to +50 °C

Chemical characteristics

Free of hazardous substances acc. to RoHS 2011/65/EU
 UV resistance according to UL 1581 and ISO 4892
 Free of lacquer-wetting substances (e.g. silicon oil)

Cable printing

LEONI MegaLine F6-90 S/F CI 4P H SPICE Code "xxxxx"
 FIRE RESISTANT EN 50289-4-16 EN 50200 PH120
 "Batch number" "Metre marking"

Colour code

WH/BU, WH/OG, WH/GN, WH/BN

Certificates and approvals

Link performance: LEONI MegaLine® systems
 and other commonly available connector systems
 Test certificates: according to DIN 55350-18-4.2.1 or EN 10204
 Compliant with LVD (2014/35/EU): **CE**

Dimension	Outer Ø approx.	Weight approx.	Copper no.*	Sheath colour	Order no.
	mm	kg/km	kg/km		
4P	10.5	133	54.9	● Jet black RAL 9005	LKD 7KS7 0324 0000)

Package: Drum 1000 m

* see page 17: Definition of copper no.

MegaLine® E5-70 S/F

Category 6_A

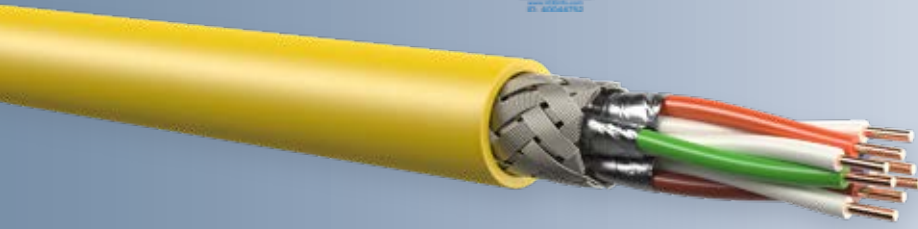

Types **KS-02YSCH 4x2xAWG 23/1 PIMF**
KS-02YSCH 2x(4x2xAWG 23/1 PIMF)

Advantages

- Better than Category 6_A
- bandwidth 700 MHz
- excellent shielding characteristics
- VDE certified
- PVP-GHMT
- RoHS and REACH conformity

Construction for 4P

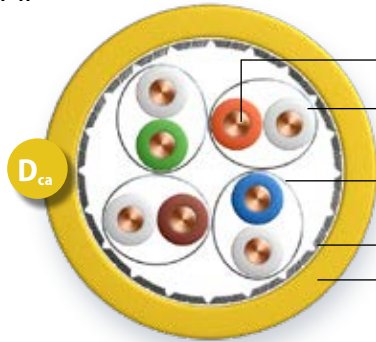

Conductor	Bare copper wire, AWG 23/1
Insulation	Cellular PE, core Ø: nominal value 1.24 mm
Twisting element	Pair
Individual shielding	Aluminium bonded polyester foil, metal on the outside (PiMF)
Twisting	4 pairs
Overall shielding	Tinned copper braid
Outer sheath	halogen-free, flame-retardant compound

Fire behaviour	
Flame retardancy	acc. to IEC 60332-3-24
Halogen free	acc. to IEC 60754-1/2
Smoke density	acc. to IEC 61034-1/2
Acid formation	acc. to EN 60754-2
Fire load (reference value)	0.60 MJ/m (Sx), 1.2 MJ/m (Dx)
EU Construction Products Regulation	acc. to EN 50575 / EN 50399

Performance	
Better than Category 6 _A , acc. to EN 50288 and IEC 61156, very good NEXT, excellent shielding characteristics (pairs and overall shielding), low skew, bandwidth (typical) 700 MHz	

Applications	
Installation cable for use in structured cabling acc. to ISO/IEC 11801 and EN 50173 (3rd Edition). Ideal for all applications of classes D to E _x , up to 10 GbE acc. to IEEE 802.3 an, cable sharing, VoIP, PoE/PoE+.	

Mechanical characteristics	
Bending radius during installation	8 x outer diameter (min.)
after installation	4 x outer diameter (min.)
Tensile strength (max.)	110 N (Sx), 220 N (Dx)
Crush strength	1000 N/100 mm
Impact strength (number of shocks)	10

Electromagnetic behaviour	
Coupling resistance at 10 MHz (nom.)	5 mΩ/m
Shield attenuation up to 1000 MHz (nom.)	60 dB
Coupling attenuation up to 1000 MHz (nom.)	80 dB
Separating class acc. to EN 50174-2	c

Security (fire behaviour)

S	1 IEC 60332-2-2	2 IEC-60332-1-2	3 IEC-60332-3-24	4 EFP Grade 1	5 EFP Grade 2
		E _{ca} /D _{ca}	E _{ca} /D _{ca}	C _{ca}	B2 _{ca}

Performance (cable class, bandwidth)

P	1 > Class E > 250 MHz	2 > Class E _x > 500 MHz	3 > Class F > 600 MHz	4 > Class F _x > 1000 MHz	5 > Class F _x + > 1200 MHz
----------	-----------------------------	--	-----------------------------	---	---

Application (ethernet, TV)

A	1 > 100 MbE	2 > 1 GbE	3 up to 10 GbE	4 > 10 GbE	5 > 10 GbE TV
----------	----------------	--------------	-------------------	---------------	------------------

Construction (conductor dimension, tensile strength)

C	1 AWG 27	2 AWG 26/25	3 AWG 24	4 AWG 23	5 AWG 22
----------	-------------	----------------	-------------	-------------	-------------

EMC (coupling attenuation)

E	1 > 40 dB	2 > 50 dB	3 > 60 dB	4 > 70 dB	5 > 80 dB
----------	--------------	--------------	--------------	--------------	--------------

Electrical characteristics (HF) at 20 °C

Frequency MHz	Attenuation dB/100 m		NEXT dB		PS-NEXT dB		ACR dB at 100 m		PS-ACR dB at 100 m		ACR-F dB at 100 m		PSACR-F dB at 100 m		RL dB	
	typ.	Cat. 6 _A max.*	typ.	Cat. 6 _A min.*	typ.	Cat. 6 _A min.*	typ.	Cat. 6 _A min.*	typ.	Cat. 6 _A min.*	typ.	Cat. 6 _A min.*	typ.	Cat. 6 _A min.*	typ.	Cat. 6 _A min.*
1	1.9	2.1	95	75.3	92	72.3	93	73.2	90	70.2	91	68	88	65	26	20
10	5.2	5.9	90	60.3	87	57.3	85	54.4	82	51.4	96	48	93	45	35.9	25
100	17.7	19.1	75	45.3	72	42.3	57	26.2	54	23.2	90	28	87	25	37.2	20.1
200	26.4	27.6	68	40.8	65	37.8	42	13.2	39	10.2	78	22	75	19	33.1	18
250	29.9	31.1	66	39.3	63	36.3	36	8.3	33	5.3	75	20	72	17	30.5	17.3
300	31.9	34.3	65	38.1	62	35.1	33	3.9	30	0.9	72	18.5	69	15.5	29.9	17.3
450	38.9	42.7	63	35.5	60	32.5	24	-7.2	21	-10.2	69	14.9	66	11.9	28.9	17.3
500	41.2	45.3	61	34.8	58	31.8	20	-10.4	17	-13.4	66	14	63	11	28.3	17.3
600	46.2	-	57	-	54	-	11	-	8	-	60	-	57	-	27.2	-
700	51.4	-	54	-	51	-	3	-	0	-	56	-	53	-	26.2	-

* EN 50288-10-1 (2013)/EN 50288-5-1 (2004)/IEC 61156-5 (2009)

Electrical characteristics (LF) at 20 °C

Direct current resistance	max.	82 Ω/km
Insulation resistance	min.	5 GΩ x km
Mutual capacitance	approx.	42 pF/m
Capacitive coupling (e)	approx.	1100 pF/km
Signal tempo (c)	approx.	0.80
Propagation delay	approx.	420 ns/100 m
Skew at 100 MHz	approx.	7 ns/100 m
Charact. impedance	at 100 MHz	100 ± 5 Ω
Testing voltage U _{eff}		1000 V
Operating voltage	max.	125 V

Thermal properties

For fixed installation	-20 °C to +60 °C
For mobile operation	0 °C to +50 °C

Chemical characteristics

Free of hazardous substances acc. to RoHS 2011/65/EU

Cable printing for 4 P

LEONI MegaLine E5-70 S/F 4P H SPACE Code "xxxxx"
 "CPR Class" "DoP no." "VDE mark" Made in Germany
 "Batch number" "Metre marking"

Colour code

WH/BU, WH/OG, WH/GN, WH/BN

Certificates and approvals

Quality mark with production control:

<VDE>, GHMT PVP

Link performance: LEONI MegaLine® systems

and other commonly available connector systems

Test certificates: according to DIN 55350-18-4.2.1 or EN 10204

Compliant with LVD (2014/35/EU): **CE**

Compliant with Construction Products Regulation

(EU/305/2011): **CE**

Dimension	Outer Ø approx.	Weight approx.	Copper no.*	CPR class	DoP no.	Sheath colour	Order no.
	mm	kg/km	kg/km				
4P	7.4	55	30	D _{ca} s2 d2 a1	CDESK0000005	● Rape yellow	LKD 7KS6 0024 xxxx
2 x 4P	7.5 x 15.2	112	60	D _{ca} s2 d2 a1	CDESK0000006	● Rape yellow	LKD 7KS6 0025 xxxx

Packaging: xxxx

Standard length: 0100 = 1000 m 0050 = 500 m 0000 = general

* see page 17: Definition of copper no.

MegaLine® E5-70 F/F

Category 6_A

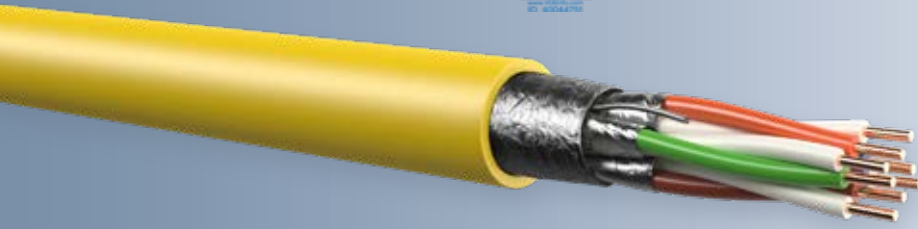

Types **KS-02YS(ST)H 4x2xAWG 23/1 PIMF**
KS-02YS(ST)H 2x(4x2xAWG 23/1 PIMF)

Advantages

- Better than Category 6_A
- bandwidth 700 MHz
- good shielding characteristics
- VDE certified
- PVP-GHMT
- RoHS and REACH conformity

Construction for 4P

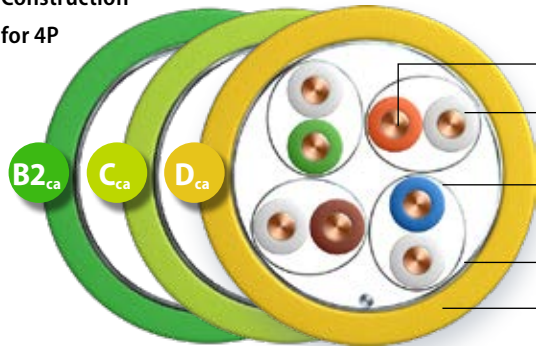

Conductor	Bare copper wire, AWG 23/1
Insulation	Cellular PE, core Ø: nominal value 1.24 mm
Twisting element	Pair
Individual shielding	Aluminium bonded polyester foil, metal on the outside (PiMF)
Twisting	4 pairs
Overall shielding	Aluminium bonded polyester foil, metal on the inside and copper supplementary cable
Outer sheath	halogen-free, flame-retardant compound

Fire behaviour

Flame retardancy	acc. to IEC 60332-3-24
Halogen free	acc. to IEC 60754-1/2
Smoke density	acc. to IEC 61034-1/2
Acid formation	acc. to EN 60754-2
Fire load (reference value)	0.60 MJ/m (Sx), 1.2 MJ/m (Dx)
EU Construction Products Regulation	acc. to EN 50575 / EN 50399

Performance

Better than Category 6_A, acc. to EN 50288 and IEC 61156, very good NEXT, good shielding characteristics (pairs and overall shielding), low skew, bandwidth (typical) 700 MHz

Applications

Installation cable for use in structured cabling acc. to ISO/IEC 11801 and EN 50173 (3rd Edition).
 Ideal for all Class D to Class E applications_A, up to 10 GbE acc. to IEEE 802.3 an, cable sharing, VoIP, PoE/PoE+.

Mechanical characteristics

Bending radius during installation	8 x outer diameter (min.)
after installation	4 x outer diameter (min.)
Tensile strength (max.)	110 N (Sx), 220 N (Dx)
Crush strength	1000 N/100 mm
Impact strength (number of shocks)	10

Electromagnetic behaviour

Coupling resistance at 10 MHz (nom.)	50 mΩ/m
Shield attenuation up to 1000 MHz (nom.)	60 dB
Coupling attenuation up to 1000 MHz (nom.)	70 dB
Separating class acc. to EN 50174-2	c

Security (fire behaviour)

S	1 IEC 60332-2-2	2 IEC-60332-1-2	3 IEC-60332-3-24	4 EFP Grade 1	5 EFP Grade 2
		E _{ca} /D _{ca}	E _{ca} /D _{ca}	C _{ca}	B2 _{ca}

Performance (cable class, bandwidth)

P	1 > Class E > 250 MHz	2 > Class E _A > 500 MHz	3 > Class F > 600 MHz	4 > Class F _A > 1000 MHz	5 > Class F _A + > 1200 MHz
----------	-----------------------------	--	-----------------------------	---	---

Application (ethernet, TV)

A	1 > 100 MbE	2 > 1 GbE	3 up to 10 GbE	4 > 10 GbE	5 > 10 GbE TV
----------	----------------	--------------	-------------------	---------------	------------------

Construction (conductor dimension, tensile strength)

C	1 AWG 27	2 AWG 26/25	3 AWG 24	4 AWG 23	5 AWG 22
----------	-------------	----------------	-------------	-------------	-------------

EMC (coupling attenuation)

E	1 > 40 dB	2 > 50 dB	3 > 60 dB	4 > 70 dB	5 > 80 dB
----------	--------------	--------------	--------------	--------------	--------------

Electrical characteristics (HF) at 20 °C

Frequency MHz	Attenuation dB/100 m		NEXT dB		PS-NEXT dB		ACR dB at 100 m		PS-ACR dB at 100 m		ACR-F dB at 100 m		PSACR-F dB at 100 m		RL dB	
	typ.	Cat. 6 _A max.*	typ.	Cat. 6 _A min.*	typ.	Cat. 6 _A min.*	typ.	Cat. 6 _A min.*	typ.	Cat. 6 _A min.*	typ.	Cat. 6 _A min.*	typ.	Cat. 6 _A min.*	typ.	Cat. 6 _A min.*
1	1.9	2.1	95	75.3	92	72.3	93	73.2	90	70.2	91	68	88	65	25.1	–
10	5.2	5.9	90	60.3	87	57.3	85	54.4	82	51.4	96	48	93	45	35.2	25
100	17.7	19.1	75	45.3	72	42.3	57	26.2	54	23.2	90	28	87	25	37.2	20.1
200	26.4	27.6	68	40.8	65	37.8	42	13.2	39	10.2	78	22	75	19	31.1	18
250	29.9	31.1	66	39.3	63	36.3	36	8.3	33	5.3	75	20	72	17	29.5	17.3
300	31.9	34.3	65	38.1	62	35.1	33	3.9	30	0.9	72	18.5	69	15.5	28.3	17.3
450	38.9	42.7	63	35.5	60	32.5	24	-7.2	21	-10.2	69	14.9	66	11.9	26.7	17.3
500	41.2	45.3	61	34.8	58	31.8	20	-10.4	17	-13.4	66	14	63	11	26.3	17.3
600	46.2	–	57	–	54	–	11	–	8	–	60	–	57	–	25.8	–
700	51.4	–	54	–	51	–	3	–	0	–	56	–	53	–	–	–

* EN 50288-10-1 (2013)/EN 50288-5-1 (2004)/IEC 61156-5 (2009)

Electrical characteristics (LF) at 20 °C

Direct current resistance	max.	82 Ω/km
Insulation resistance	min.	5 GΩ x km
Mutual capacitance	approx.	42 pF/m
Capacitive coupling (e)	approx.	1100 pF/km
Signal tempo (c)	approx.	0.80
Propagation delay	approx.	417 ns/100 m
Skew at 100 MHz	approx.	7 ns/100 m
Charact. impedance	at 100 MHz	100 ± 5 Ω
Testing voltage U _{eff}		1000 V
Operating voltage	max.	125 V

Thermal properties

For fixed installation	–20 °C to +60 °C
For mobile operation	0 °C to +50 °C

Chemical characteristics

Free of hazardous substances acc. to RoHS 2011/65/EU

Cable printing for 4P

LEONI MegaLine E5-70 F/F 4P H SPACE Code "xxxxx"
 "CPR Class" "DoP no." "VDE mark" Made in Germany
 "Batch number" "Metre marking"

Colour code

WH/BU, WH/OG, WH/GN, WH/BN

Certificates and approvals

Quality mark with production control:

<VDE>, GHMT PVP

Link performance: LEONI MegaLine® systems





and other commonly available connector systems

Test certificates: according to DIN 55350-18-4.2.1 or EN 10204

Compliant with LVD (2014/35/EU): 

Compliant with Construction Products Regulation

(EU/305/2011): 

Dimension	Outer Ø approx.	Weight approx.	Copper no.*	CPR class	DoP no.	Sheath colour	Order no.
	mm	kg/km	kg/km				
4P	7.5	58	23.5	D _{ca} s2 d2 a1	CDESK0000003	 Rape yellow	LKD 7KS6 0022 xxxx
2 x 4P	7.5 x 15.2	120	47	D _{ca} s2 d2 a1	CDESK0000004	 Rape yellow	LKD 7KS6 0023 xxxx
4P	7.5	58	23.5	C _{ca} s1 d1 a1	CDESK0000042	 Lime green	LKD 7KS6 C022 xxxx
4P	7.5	58	23.5	B2 _{ca} s1a d1 a1	CDESK0000041	 Yellow green	LKD 7KS6 B022 xxxx

Packaging: xxxx

Standard length: 0100 = 1000 m 0050 = 500 m 0000 = general

* see page 17: Definition of copper no.

MegaLine® E5-60 U/F

Category 6_A

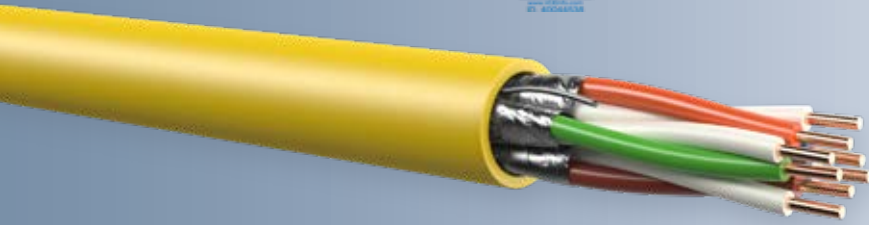

Types **KS-02YSH 4x2xAWG 23/1 PIMF**
KS-02YSH 2x(4x2xAWG 23/1 PIMF)

Advantages

- Better than Category 6_A
- bandwidth 600 MHz
- VDE certified
- PVP-GHMT
- RoHS and REACh conformity

Construction for 4P

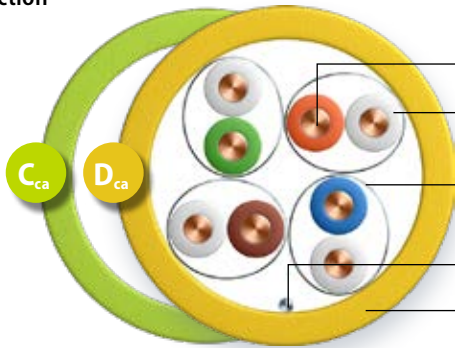

Conductor	Bare copper wire, AWG 23/1
Insulation	Cellular PE, core Ø: nominal value 1.24 mm
Twisting element	Pair
Individual shielding	Aluminium bonded polyester foil, metal on the outside (PiMF)
Twisting	4 pairs
Overall shielding	plastic foil (optional) and supplementary copper wire AWG24/1
Outer sheath	halogen-free, flame-retardant compound

Fire behaviour

Flame retardancy	acc. to IEC 60332-3-24
Halogen free	acc. to IEC 60754-1/2
Smoke density	acc. to IEC 61034-1/2
Acid formation	acc. to EN 60754-2
Fire load (reference value)	0.60 MJ/m (Sx), 1.2 MJ/m (Dx)
EU Construction Products Regulation	acc. to EN 50575 / EN 50399

Performance

Better than Category 6_A, acc. to EN 50288 and IEC 61156
 very good NEXT, good shielding characteristics (pairs and overall shielding),
 low skew, bandwidth (typical) 600 MHz

Applications

Installation cable for use in structured cabling acc. to ISO/IEC 11801 and EN 50173 (3rd Edition).
 Ideal for all applications of classes D to E_A up to 10 GbE acc. to IEEE 802.3 an, cable sharing, VoIP, PoE/PoE+.

Mechanical characteristics

Bending radius during installation	8 x outer diameter (min.)
after installation	4 x outer diameter (min.)
Tensile strength (max.)	110 N (Sx), 220 N (Dx)
Crush strength	1000 N/100 mm
Impact strength (number of shocks)	10

Electromagnetic behaviour

Coupling resistance at 10 MHz (nom.)	50 mΩ/m
Shield attenuation up to 1000 MHz (nom.)	55 dB
Coupling attenuation up to 1000 MHz (nom.)	65 dB
Separating class acc. to EN 50174-2	c

Security (fire behaviour)

S	1 IEC 60332-2-2	2 IEC-60332-1-2	3 IEC-60332-3-24	4 EFP Grade 1	5 EFP Grade 2
		E _{ca} /D _{ca}	E _{ca} /D _{ca}	C _{ca}	B2 _{ca}

Performance (cable class, bandwidth)

P	1 > Class E > 250 MHz	2 > Class E _A > 500 MHz	3 > Class F > 600 MHz	4 > Class F _A > 1000 MHz	5 > Class F _A + > 1200 MHz
----------	-----------------------------	--	-----------------------------	---	---

Application (ethernet, TV)

A	1 > 100 MbE	2 > 1 GbE	3 up to 10 GbE	4 > 10 GbE	5 > 10 GbE TV
----------	----------------	--------------	-------------------	---------------	------------------

Construction (conductor dimension, tensile strength)

C	1 AWG 27	2 AWG 26/25	3 AWG 24	4 AWG 23	5 AWG 22
----------	-------------	----------------	-------------	-------------	-------------

EMC (coupling attenuation)

E	1 > 40 dB	2 > 50 dB	3 > 60 dB	4 > 70 dB	5 > 80 dB
----------	--------------	--------------	--------------	--------------	--------------

Electrical characteristics (HF) at 20 °C

Frequency MHz	Attenuation dB/100 m		NEXT dB		PS-NEXT dB		ACR dB at 100 m		PS-ACR dB at 100 m		ACR-F dB at 100 m		PSACR-F dB at 100 m		RL dB	
	typ.	Cat. 6 _A max.*	typ.	Cat. 6 _A min.*	typ.	Cat. 6 _A min.*	typ.	Cat. 6 _A min.*	typ.	Cat. 6 _A min.*	typ.	Cat. 6 _A min.*	typ.	Cat. 6 _A min.*	typ.	Cat. 6 _A min.*
1	1.9	2.1	95	75.3	92	72.3	93	73.2	90	70.2	91	68	88	65	25.1	–
10	5.2	5.9	90	60.3	87	57.3	85	54.4	82	51.4	96	48	93	45	35.2	25
100	17.7	19.1	75	45.3	72	42.3	57	26.2	54	23.2	90	28	87	25	37.2	20.1
200	26.4	27.6	68	40.8	65	37.8	42	13.2	39	10.2	78	22	75	19	31.1	18
250	29.9	31.1	66	39.3	63	36.3	36	8.3	33	5.3	75	20	72	17	29.5	17.3
300	31.9	34.3	65	38.1	62	35.1	33	3.9	30	0.9	72	18.5	69	15.5	28.3	17.3
450	38.9	42.7	63	35.5	60	32.5	24	-7.2	21	-10.2	69	14.9	66	11.9	26.7	17.3
500	41.2	45.3	61	34.8	58	31.8	20	-10.4	17	-13.4	66	14	63	11	26.3	17.3
600	46.2	–	57	–	54	–	11	–	8	–	60	–	57	–	25.8	–

* EN 50288-10-1 (2013)/EN 50288-5-1(2004)/IEC 61156-5 (2009)

Electrical characteristics (LF) at 20 °C

Direct current resistance	max.	82 Ω/km
Insulation resistance	min.	5 GΩ x km
Mutual capacitance	approx.	42 pF/m
Capacitive coupling (e)	approx.	1100 pF/km
Signal tempo (c)	approx.	0.80
Propagation delay	approx.	420 ns/100 m
Skew at 100 MHz	approx.	7 ns/100 m
Charact. impedance	at 100 MHz	100 ± 5 Ω
Testing voltage U _{eff}		1000 V
Operating voltage	max.	125 V

Thermal properties

For fixed installation	–20 °C to +60 °C
For mobile operation	0 °C to +50 °C

Chemical characteristics

Free of hazardous substances acc. to RoHS 2011/65/EU



Cable printing for 4 P

LEONI MegaLine E5-60 U/F 4P H SPACE Code "xxxxx"
 "CPR Class" "DoP no." "VDE mark" Made in Germany
 "Batch number" "Metre marking"

Colour code

WH/BU, WH/OG, WH/GN, WH/BN

Certificates and approvals

Quality mark with production control: <VDE>
 Link performance: LEONI MegaLine® systems
 and other commonly available connector systems
 Test certificates: according to DIN 55350-18-4.2.1 or EN 10204
 Compliant with LVD (2014/35/EU): 
 Compliant with Construction Products Regulation
 (EU/305/2011): 

Dimension	Outer Ø approx.	Weight approx.	Copper no.*	CPR class	DoP no.	Sheath colour	Order no.
	mm	kg/km	kg/km				
4P	7.2	53	23.5	D _{ca} s2 d2 a1	CDESK0000001	● Rape yellow	LKD 7KS6 0035 xxxx
2 x 4P	7.4 x 15.0	112	47	D _{ca} s2 d2 a1	CDESK0000002	● Rape yellow	LKD 7KS6 0036 xxxx
4P	7.2	53	23.5	C _{ca} s1 d1 a1	CDESK0000043	● Lime green	LKD 7KS6 C035 xxxx

Packaging: xxxx

Standard length: 0100 = 1000 m 0050 = 500 m 0000 = general

* see page 17: Definition of copper no.

MegaLine® E2-45 U/F

Category 6

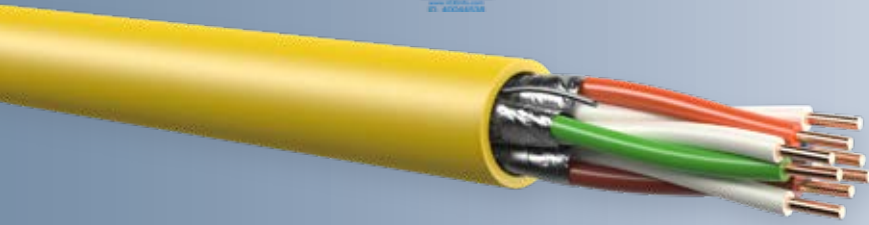

Types **KS-02YSH 4x2xAWG 23/1 PIMF**
KS-02YSH 2x(4x2xAWG 23/1 PIMF)

Advantages

- Better than Category 6
- bandwidth 450 MHz
- VDE certified
- RoHS and REACh conformity

Construction for 4P

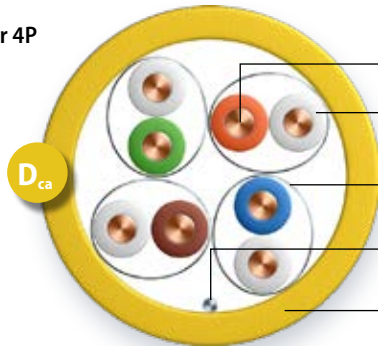

Conductor	Bare copper wire, AWG 23/1
Insulation	Cellular PE, core Ø: nominal value 1.24 mm
Twisting element	Pair
Individual shielding	Aluminium bonded polyester foil, metal on the outside (PiMF)
Twisting	4 pairs
Taping	plastic foil (optional) and supplementary copper wire AWG24/1
Outer sheath	halogen-free, flame-retardant compound

Fire behaviour

Flame retardancy	acc. to IEC 60332-1-2
Halogen free	acc. to IEC 60754-1/2
Smoke density	acc. to IEC 61034-1/2
Acid formation	acc. to EN 60754-2
Fire load (reference value)	0.60 MJ/m (Sx), 1.2 MJ/m (Dx)
EU Construction Products Regulation	acc. to EN 50575 / EN 50399

Performance

Better than Category 6 acc. to EN 50288 and IEC 61156
 very good NEXT, low skew, bandwidth (typical) 450 MHz

Applications

Installation cable for use in structured cabling acc. to ISO/IEC 11801 and EN 50173 (3rd Edition).
 Ideal for all applications of classes D to E up to 1 GbE acc. to IEEE 802.3 ab, cable sharing, VoIP, PoE/PoE+.

Mechanical characteristics

Bending radius during installation	8 x outer diameter (min.)
after installation	4 x outer diameter (min.)
Tensile strength (max.)	110 N (Sx), 220 N (Dx)
Crush strength	1000 N/100 mm
Impact strength (number of shocks)	10

Electromagnetic behaviour

Coupling resistance at 10 MHz (nom.)	80 mΩ/m
Shield attenuation up to 1000 MHz (nom.)	50 dB
Coupling attenuation up to 1000 MHz (nom.)	60 dB
Separating class acc. to EN 50174-2	b

Security (fire behaviour)

S	1 IEC 60332-2-2	2 IEC-60332-1-2	3 IEC-60332-3-24	4 EFP Grade 1	5 EFP Grade 2
		E _{ca} /D _{ca}	E _{ca} /D _{ca}	C _{ca}	B2 _{ca}

Performance (cable class, bandwidth)

P	1 > Class E > 250 MHz	2 > Class E _A > 500 MHz	3 > Class F > 600 MHz	4 > Class F _A > 1000 MHz	5 > Class F _A + > 1200 MHz
----------	-----------------------------	--	-----------------------------	---	---

Application (Ethernet, TV)

A	1 > 100 MbE	2 > 1 GbE	3 up to 10 GbE	4 > 10 GbE	5 > 10 GbE TV
----------	----------------	--------------	-------------------	---------------	------------------

Construction (conductor dimension, tensile strength)

C	1 AWG 27	2 AWG 26/25	3 AWG 24	4 AWG 23	5 AWG 22
----------	-------------	----------------	-------------	-------------	-------------

EMC (coupling attenuation)

E	1 > 40 dB	2 > 50 dB	3 > 60 dB	4 > 70 dB	5 > 80 dB
----------	--------------	--------------	--------------	--------------	--------------

Electrical characteristics (HF) at 20 °C

Frequency MHz	Attenuation dB/100 m		NEXT dB		PS-NEXT dB		ACR dB at 100 m		PS-ACR dB at 100 m		EL-FEXT dB at 100 m		PS-ELFEXT dB at 100 m		RL dB	
	typ.	Cat. 6 max.*	typ.	Cat. 6 min.*	typ.	Cat. 6 min.*	typ.	Cat. 6 min.*	typ.	Cat. 6 min.*	typ.	Cat. 6 min.*	typ.	Cat. 6 min.*	typ.	Cat. 6 min.*
1	1.9	2.1	95	66	92	64	93	64	90	62	88	66	85	64	25.4	–
4	3.2	3.8	95	65	92	63	92	61	89	59	89	58	86	55	28.6	23
10	5.2	6	90	59	87	57	85	53	82	51	92	50	89	47	33.5	25
16	7	7.6	90	56	87	54	83	49	80	47	98	46	95	43	35.6	25
31.25	9.9	10.7	85	52	82	50	75	41	72	39	98	40	95	37	37	23.6
62.5	13.5	15.5	80	47	77	45	66	32	63	30	95	34	92	31	35.9	21.5
100	17.9	19.9	75	44	72	42	57	24	54	22	88	30	85	27	34.3	20.1
155	22.5	25.3	72	41	69	39	49	16	46	14	81	26	78	23	32.2	18.8
200	26.9	29.1	68	40	65	38	41	11	38	9	75	24	72	21	31.3	18
250	30.4	33	66	38	63	36	36	5	33	3	72	22	69	19	29.2	17.3
300	33.1	–	65	–	62	–	32	–	29	–	69	–	66	–	28	–
450	39.3	–	63	–	60	–	24	–	21	–	64	–	61	–	27	–

* EN 50288-5-1(2014)/IEC 61156-5 (2009)

Electrical characteristics (LF) at 20 °C

Direct current resistance	max.	82 Ω/km
Insulation resistance	min.	5 GΩ x km
Mutual capacitance	approx.	42 pF/m
Capacitive coupling (e)	approx.	1100 pF/km
Signal tempo (c)	approx.	0.80
Propagation delay	approx.	420 ns/100 m
Skew at 100 MHz	approx.	7 ns/100 m
Charact. impedance	at 100 MHz	100 ± 5 Ω
Testing voltage U _{eff}		1000 V
Operating voltage	max.	125 V

Thermal properties

For fixed installation	–20 °C to +60 °C
For mobile operation	0 °C to +50 °C

Chemical characteristics

Free of hazardous substances acc. to RoHS 2011/65/EU



Cable printing for 4 P

LEONI MegaLine E2-45 U/F 4P H SPACE Code "xxxxx"
 "CPR Class" "DoP no." "VDE mark" Made in Germany
 "Batch number" "Metre marking"

Colour code

WH/BU, WH/OG, WH/GN, WH/BN

Certificates and approvals

Quality mark with production control: <VDE>
 Link performance: LEONI MegaLine® systems
 and other commonly available connector systems
 Test certificates: according to DIN 55350-18-4.2.1 or EN 10204
 Compliant with LVD (2014/35/EU): 
 Compliant with Construction Products Regulation
 (EU/305/2011): 

Dimension	Outer Ø approx.	Weight approx.	Copper no.*	CPR class	DoP no.	Sheath colour	Order no.
	mm	kg/km	kg/km				
4P	7.4	55	23.5	D _{ca} s2 d2 a1	CDESK0000001	● Rape yellow	LKD 7KS6 0005 xxxx
2 x 4P	7.4 x 15.0	114	47	D _{ca} s2 d2 a1	CDESK0000002	● Rape yellow	LKD 7KS6 0006 xxxx

Packaging: xxxx

Standard length: 0100 = 1000 m 0050 = 500 m 0000 = general

* see page 17: Definition of copper no.

MegaLine® E2-30 U/U

Category 6

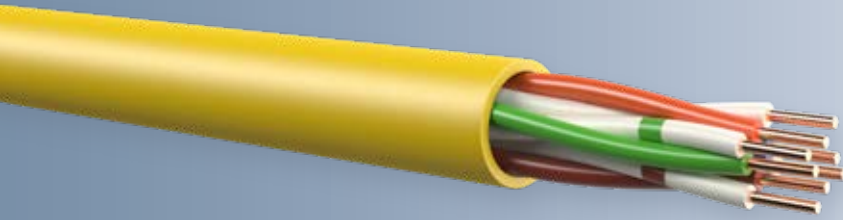

Type KS-2YH 4x2xAWG 23/1

Advantages

- Better than Category 6
- bandwidth 300 MHz
- RoHS and REACh conformity

Construction for 4P

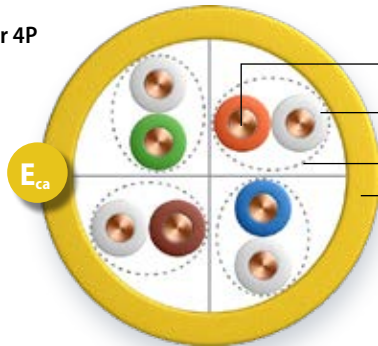

Conductor	Bare copper wire, AWG 23/1
Insulation	PE
Twisting element	Pair
Twisting	4 pairs separated by a cross element
Outer sheath	halogen-free, flame-retardant compound

Fire behaviour

Flame retardancy	acc. to IEC 60332-1-2
Halogen free	acc. to IEC 60754-1/2
Smoke density	acc. to IEC 61034-1/2
Acid formation	acc. to EN 60754-2
Fire load (reference value)	0.65 MJ/m
EU Construction Products Regulation	acc. to EN 50575 / EN 50399

Performance

Better than Category 6 acc. to EN 50288 and IEC 61156, bandwidth (typical) 300 MHz

Applications

Installation cable for use in structured cabling acc. to ISO/IEC 11801 and EN 50173 (3rd Edition).
Ideal for all applications of classes D to E up to 1 GbE acc. to IEEE 802.3 ab, VoIP, PoE/PoE+.

Mechanical characteristics

Bending radius during installation	8 x outer diameter (min.)
after installation	4 x outer diameter (min.)
Tensile strength (max.)	110 N
Crush strength	1000 N/100 mm
Impact strength (number of shocks)	10

Electromagnetic behaviour

Coupling attenuation up to 1000 MHz (nom.)	45 dB
Separating class acc. to EN 50174-2	b

Security (fire behaviour)

S	1 IEC 60332-2-2	2 IEC-60332-1-2	3 IEC-60332-3-24	4 EFP Grade 1	5 EFP Grade 2
		E _{ca} /D _{ca}	E _{ca} /D _{ca}	C _{ca}	B2 _{ca}

Performance (cable class, bandwidth)

P	1 > Class E > 250 MHz	2 > Class E _A > 500 MHz	3 > Class F > 600 MHz	4 > Class F _A > 1000 MHz	5 > Class F _A + > 1200 MHz

Application (ethernet, TV)

A	1 > 100 MbE	2 > 1 GbE	3 up to 10 GbE	4 > 10 GbE	5 > 10 GbE TV

Construction (conductor dimension, tensile strength)

C	1 AWG 27	2 AWG 26/25	3 AWG 24	4 AWG 23	5 AWG 22

EMC (coupling attenuation)

E	1 > 40 dB	2 > 50 dB	3 > 60 dB	4 > 70 dB	5 > 80 dB

Electrical characteristics (HF) at 20 °C

Frequency MHz	Attenuation dB/100 m		NEXT dB		PS-NEXT dB		ACR dB at 100 m		PS-ACR dB at 100 m		EL-FEXT dB at 100 m		PS-ELFEXT dB at 100 m		RL dB	
	typ.	Cat. 6 max.*	typ.	Cat. 6 min.*	typ.	Cat. 6 min.*	typ.	Cat. 6 min.*	typ.	Cat. 6 min.*	typ.	Cat. 6 min.*	typ.	Cat. 6 min.*	typ.	Cat. 6 min.*
1	1.8	2.1	94	66	91	64	92	64	89	62	102	66	99	64	25.4	–
4	2.7	3.8	88	65	85	63	85	61	82	59	96	58	93	55	30.3	23
10	4.7	6	81	59	78	57	76	53	73	51	85	50	82	47	33.9	25
16	6.6	7.6	76	56	73	54	70	49	67	47	78	46	75	43	33.6	25
32.25	9.5	10.9	72	52	69	50	62	41	59	39	70	40	67	37	33.7	23.6
62.5	13	15.5	68	47	65	45	55	32	52	30	63	34	60	31	34.4	21.5
100	17.4	19.9	64	44	61	42	46	24	43	22	57	30	54	27	33.5	20.1
155	22	25.3	60	41	57	39	38	16	35	14	50	26	47	23	32.2	18.8
200	26.6	29.1	58	40	55	38	31	11	28	9	45	24	42	21	30.5	18
250	30.4	33	57	38	54	36	27	5	24	3	40	22	37	19	29	17.3
300	33.1	–	54	–	51	–	20	–	17	–	37	–	34	–	27	–

* EN 50288-6-1(2014)/IEC 61156-5 (2009)

Electrical characteristics (LF) at 20 °C

Direct current resistance	max.	78 Ω/km
Insulation resistance	min.	5 GΩ x km
Mutual capacitance	approx.	50 pF/m
Capacitive coupling (e)	approx.	1100 pF/km
Signal tempo (c)	approx.	0.67
Propagation delay	approx.	528 ns/100 m
Skew at 100 MHz	approx.	30 ns/100 m
Charact. impedance	at 100 MHz	100 ± 5 Ω
Testing voltage U _{eff}		1000 V
Operating voltage	max.	125 V

Thermal properties

For fixed installation	–20 °C to +60 °C
For mobile operation	0 °C to +50 °C

Chemical characteristics

Free of hazardous substances acc. to RoHS 2011/65/EU

Cable printing

LEONI MegaLine E2-30 U/U 4P H SPACE Code "xxxxx"
"CPR Class" "DoP no." "Batch number" "Metre marking"

Colour code

WH-BU/BU, WH-OG/OG, WH-GN/GN, WH-BN/BN

Certificates and approvals

Link performance: LEONI MegaLine® systems
and other commonly available connector systems
Test certificates: according to DIN 55350-18-4.2.1 or EN 10204
Compliant with LVD (2014/35/EU): **CE**
Compliant with Construction Products Regulation
(EU/305/2011): **CE**

Dimension	Outer Ø approx.	Weight approx.	Copper no.*	CPR class	DoP no.	Sheath colour	Order no.
	mm	kg/km	kg/km				
4P	6.4	45	21	E _a	CDESK0000011	● Rape yellow	LKD 7KS6 0002 xxxx

Packaging: xxxx

Standard length: 0100 = 1000 m 0050 = 500 m 0000 = general

* see page 17: Definition of copper no.

MegaLine® D1-20 SF/U

Category 5

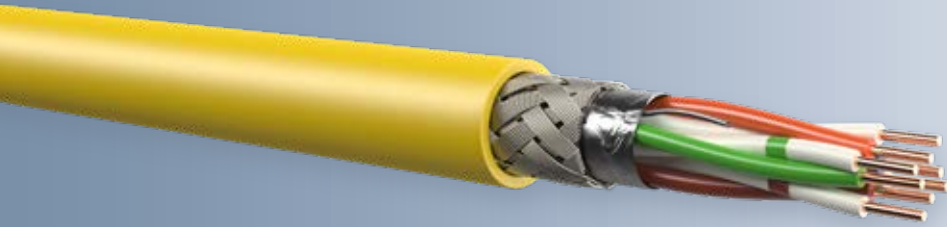

Types **KS-02YS(ST+C)H 4x2xAWG 24/1**
KS-02YS(ST+C)H 2x(4x2xAWG 24/1)

Advantages

- Better than Category 5
- bandwidth 200 MHz
- good shielding characteristics
- RoHS and REACh conformity

Construction for 4P

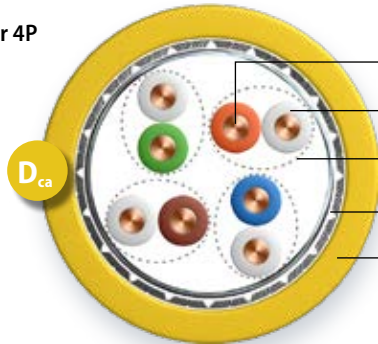

Conductor	Bare copper wire, AWG 24/1
Insulation	Cellular PE, core Ø: nominal value 1.1 mm
Twisting element	Pair
Twisting	4 pairs
Overall shielding	Aluminium bonded polyester foil and Tinned copper braid
Outer sheath	halogen-free, flame-retardant compound

Fire behaviour	
Flame retardancy	acc. to IEC 60332-1-2
Halogen free	acc. to IEC 60754-1/2
Acid formation a	cc. to EN 60754-2
Fire load (reference value)	0.4 MJ/m (Sx), 0.81 MJ/m (Dx)
EU Construction Products Regulation	acc. to EN 50575 / EN 50399

Performance	
Better than Category 5 acc. to EN 50288 and IEC 61156	
excellent shielding characteristics, bandwidth (typical) 200 MHz	

Applications	
Installation cable for use in structured cabling acc. to ISO/IEC 11801 and EN 50173 (3rd Edition).	
Ideal for all applications of classes D up to 1 GbE acc. to IEEE 802.3 ab, VoIP, PoE/PoE+.	

Mechanical characteristics	
Bending radius during installation	8 x outer diameter (min.)
after installation	4 x outer diameter (min.)
Tensile strength (max.)	85 N (Sx), 170 N (Dx)
Crush strength	1000 N/100 mm
Impact strength (number of shocks)	10

Electromagnetic behaviour	
Coupling resistance at 10 MHz (nom.)	10 mΩ/m
Shield attenuation up to 1000 MHz (nom.)	55 dB
Coupling attenuation up to 1000 MHz (nom.)	70 dB
Separating class acc. to EN 50174-2	c

Security (fire behaviour)

S	1 IEC 60332-2-2	2 IEC-60332-1-2 E_{ca}/D_{ca}	3 IEC-60332-3-24 E_{ca}/D_{ca}	4 EFP Grade 1 C_{ca}	5 EFP Grade 2 B2_{ca}
----------	--------------------	--	---	---	--

Performance (cable class, bandwidth)

P	1 > Class E > 250 MHz	2 > Class E _A > 500 MHz	3 > Class F > 600 MHz	4 > Class F _A > 1000 MHz	5 > Class F _A + > 1200 MHz
----------	-----------------------------	--	-----------------------------	---	---

Application (ethernet, TV)

A	1 > 100 MbE	2 > 1 GbE	3 up to 10 GbE	4 > 10 GbE	5 > 10 GbE TV
----------	----------------	--------------	-------------------	---------------	------------------

Construction (conductor dimension, tensile strength)

C	1 AWG 27	2 AWG 26/25	3 AWG 24	4 AWG 23	5 AWG 22
----------	-------------	----------------	-------------	-------------	-------------

EMC (coupling attenuation)

E	1 > 40 dB	2 > 50 dB	3 > 60 dB	4 > 70 dB	5 > 80 dB
----------	--------------	--------------	--------------	--------------	--------------

Electrical characteristics (HF) at 20 °C

Frequency MHz	Attenuation dB/100 m		NEXT dB		PS-NEXT dB		ACR dB at 100 m		PS-ACR dB at 100 m		EL-FEXT dB at 100 m		PS-ELFEXT dB at 100 m		RL dB	
	typ.	Cat. 5 max.*	typ.	Cat. 5 min.*	typ.	Cat. 5 min.*	typ.	Cat. 5 min.*	typ.	Cat. 5 min.*	typ.	Cat. 5 min.*	typ.	Cat. 5 min.*	typ.	Cat. 5 min.*
1	2	2.1	75	65	72	62	73	63	70	60	89	64	86	61	24.8	–
4	3.1	4	69	56	66	53	66	52	63	49	84	52	81	49	28.6	23
10	5.1	6.3	62	50	59	47	57	44	54	41	76	44	73	41	33.3	25
16	7	8	58	47	55	44	51	39	48	36	70	40	67	37	34.3	25
31.25	9.7	11.4	53	43	50	40	44	31	41	28	63	34	60	31	33.9	23.6
62.5	13.2	16.5	49	38	46	35	36	22	33	19	58	28	55	25	31.3	21.5
100	17.6	21.3	45	35	42	32	28	14	25	11	52	24	49	21	27.7	20.1
155	22.3	–	42	–	39	–	20	–	17	–	49	–	46	–	24.7	–
200	26.5	–	40	–	37	–	14	–	11	–	45	–	42	–	22.4	–

* EN 50288-2-1(2014)/IEC 61156-5 (2009)

Electrical characteristics (LF) at 20 °C

Direct current resistance	max.	95 Ω/km
Insulation resistance	min.	5 GΩ x km
Mutual capacitance	approx.	45 pF/m
Capacitive coupling (e)	approx.	1100 pF/km
Signal tempo (c)	approx.	0.75
Propagation delay	approx.	440 ns/100 m
Skew at 100 MHz	approx.	15 ns/100 m
Charact. impedance	at 100 MHz	100 ± 5 Ω
Testing voltage U _{eff}		1000 V
Operating voltage	max.	125 V

Thermal properties

For fixed installation	–20 °C to +60 °C
For mobile operation	0 °C to +50 °C

Chemical characteristics

Free of hazardous substances acc. to RoHS 2011/65/EU

Cable printing for 4P

LEONI MegaLine D1–20 SF/U 4P H SPACE Code "xxxxx"
 "CPR Class" "DoP no." Made in Germany "Batch number"
 "Metre marking"

Colour code

WH-BU/BU, WH-OG/OG, WH-GN/GN, WH-BN/BN

Certificates and approvals

Link performance: LEONI MegaLine® systems
 and other commonly available connector systems
 Test certificates: according to DIN 55350-18-4.2.1 or EN 10204
 Compliant with LVD (2014/35/EU): **CE**
 Compliant with Construction Products Regulation
 (EU/305/2011): **CE**

Dimension	Outer Ø approx.	Weight approx.	Copper no.*	CPR class	DoP no.	Sheath colour	Order no.
	mm	kg/km	kg/km				
4P	6.0	42	26	D _{ca} s2 d2 a1	CDESK0000020	● Rape yellow	LKD 7KS5 0005 xxxx
2 x 4P	6.0 x 12.5	86	52	D _{ca} s2 d2 a1	CDESK0000021	● Rape yellow	LKD 7KS5 0006 xxxx

Packaging: xxxx

Standard length: 0100 = 1000 m 0050 = 500 m 0000 = general

* see page 17: Definition of copper no.

MegaLine® Pro 1500

Category 7_A

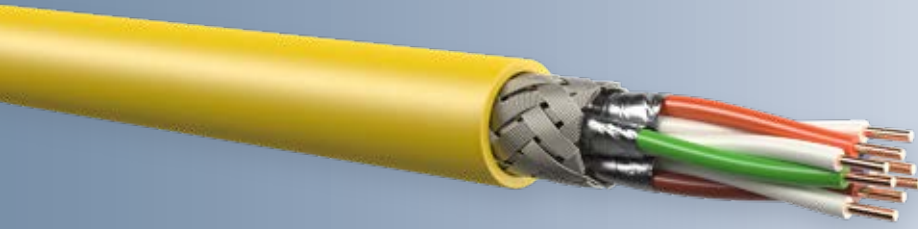

Types **KS-02YSCH 4x2xAWG22/1 PIMF**
KS-02YSCH 2x(4x2xAWG22/1 PIMF)

Advantages

- Better than Category 7_A
- bandwidth 1500 MHz
- RoHS and REACh conformity

Construction for 4P

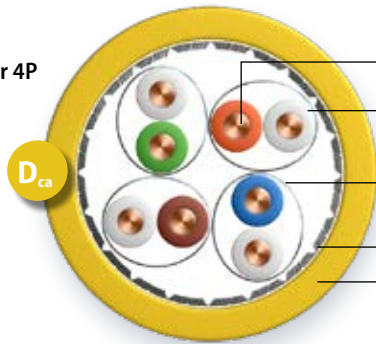

Conductor	Bare copper wire, AWG 22/1
Insulation	Cellular PE, core Ø: nominal value 1.6 mm
Twisting element	Pair
Individual shielding	Aluminium bonded polyester foil, metal on the outside (PiMF)
Twisting	4 pairs
Overall shielding	Tinned copper braid
Outer sheath	halogen-free, flame-retardant compound

Fire behaviour

Flame retardancy	acc. to IEC 60332-3-24
Halogen free	acc. to IEC 60754-1/2
Smoke density	acc. to IEC 61034-1/2
Fire load (reference value)	0.65 MJ/m (Sx), 1.33 MJ/m (Dx)
Acid formation	acc. to EN 60754-2
EU Construction Products Regulation	acc. to EN 50575 / EN 50399

Performance

Better than Category 7, acc. to EN 50288 and IEC 61156
 excellent NEXT, low attenuation, excellent shielding characteristics (pairs and overall shielding), low skew, bandwidth (typical) 1500 MHz

Applications

Installation cable for use in structured cabling acc. to ISO/IEC 11801 and EN 50173 (3rd Edition).
 Ideal for all applications of Classes D to F_A, **multimedia** (video, data, voice) > 10 GbE acc. to IEEE 802.3 an, cable sharing, VoIP, PoE/PoE+.

Mechanical characteristics

Bending radius during installation	8 x outer diameter (min.)
after installation	4 x outer diameter (min.)
Tensile strength (max.)	110 N (Sx), 220 N (Dx)
Crush strength	1000 N/100 mm
Impact strength (number of shocks)	10

Electromagnetic behaviour

Coupling resistance at 10 MHz (nom.)	5 mΩ/m
Shield attenuation up to 1000 MHz (nom.)	70 dB
Coupling attenuation up to 1000 MHz (nom.)	85 dB
Separating class acc. to EN 50174-2	d

Security (fire behaviour)

S	1 IEC 60332-2-2	2 IEC-60332-1-2	3 IEC-60332-3-24	4 EFP Grade 1	5 EFP Grade 2
		E _{ca} /D _{ca}	E _{ca} /D _{ca}	C _{ca}	B2 _{ca}

Performance (cable class, bandwidth)

P	1 > Class E > 250 MHz	2 > Class E _A > 500 MHz	3 > Class F > 600 MHz	4 > Class F _A > 1000 MHz	5 > Class F _A + > 1200 MHz
----------	-----------------------------	--	-----------------------------	---	---

Application (ethernet, TV)

A	1 > 100 MbE	2 > 1 GbE	3 up to 10 GbE	4 > 10 GbE	5 > 10 GbE TV
----------	----------------	--------------	-------------------	---------------	------------------

Construction (conductor dimension, tensile strength)

C	1 AWG 27	2 AWG 26/25	3 AWG 24	4 AWG 23	5 AWG 22
----------	-------------	----------------	-------------	-------------	-------------

EMC (coupling attenuation)

E	1 > 40 dB	2 > 50 dB	3 > 60 dB	4 > 70 dB	5 > 80 dB
----------	--------------	--------------	--------------	--------------	--------------

Electrical characteristics (HF) at 20 °C

Frequency MHz	Attenuation dB/100 m		NEXT dB		PS-NEXT dB		ACR dB at 100 m		PS-ACR dB at 100 m		EL-FEXT dB at 100 m		PS-ELFEXT dB at 100 m		RL dB	
	typ.	Cat. 7 _A max.	typ.	Cat. 7 _A min.*	typ.	Cat. 7 _A min.*	typ.	Cat. 7 _A min.*	typ.	Cat. 7 _A min.*	typ.	Cat. 7 _A min.*	typ.	Cat. 7 _A min.*	typ.	Cat. 7 _A min.*
1	1.8	2.1	105	78	102	75	103	75.9	100	72.9	106	78	103	75	32	20
10	4.7	5.8	105	78	102	75	100	72.2	97	69.2	98	75.3	95	72.3	35	25
100	16.4	18.5	105	75.4	102	72.4	89	56.9	86	53.9	87	55.3	84	52.3	26	20.1
200	23.6	26.5	101	70.9	98	67.9	77	44.4	74	41.4	80	49.3	77	46.3	25	18
250	26.4	29.7	101	69.4	98	66.4	74	39.7	71	36.7	77	47.3	74	44.3	23	17.3
500	38.2	42.8	100	64.9	97	61.9	62	22.2	59	19.2	64	41.3	61	38.3	21	17.3
600	42.0	47.1	100	63.7	97	60.7	58	16.6	55	13.6	59	39.7	56	36.7	21	17.3
800	48.5	54.9	95	61.9	92	58.9	46	6.9	43	3.9	53	37.2	50	34.2	19	16.1
900	52.0	58.5	95	61.1	92	58.1	43	2.6	40	-0.4	49	36.2	46	33.2	18	15.5
1000	55.3	61.9	92	60.4	89	57.4	37	-1.5	34	-4.5	45	35.3	42	32.3	18	15.1
1200	61.7	-	88	-	85	-	26	-	23	-	38	-	35	-	18	-
1300	64.8	-	81	-	78	-	16	-	13	-	35	-	32	-	16	-
1400	66.2	-	74	-	71	-	8	-	5	-	34	-	31	-	10	-
1500	68.5	-	73	-	70	-	5	-	2	-	31	-	28	-	9	-

* EN 50288-9-1(2013)/IEC 61156-5(2009). If IO FEXT is min. 90 dB, EL-FEXT is fulfilled by design.

Electrical characteristics at 20 °C

Direct current resistance	max.	57.1 Ω/km
Insulation resistance	min.	5 GΩ x km
Mutual capacitance	approx.	42 pF/m
Capacitive coupling (e)	approx.	1100 pF/km
Signal tempo (c)	approx.	0.77
Propagation delay	approx.	420 ns/100 m
Skew at 100 MHz	approx.	5 ns/100 m
Charact. impedance	at 100 MHz	100 ± 5 Ω
Testing voltage U _{eff}		1000 V
Operating voltage	max.	125 V

Thermal properties

For fixed installation	-20 °C to +60 °C
For mobile operation	0 °C to +50 °C

Chemical characteristics

Free of hazardous substances acc. to RoHS 2011/65/EU

Cable printing for 4 P

LEONI MegaLine Pro 1500 "CPR Class" "DoP no."
Made in Germany "Batch number" "Metre marking"

Colour code

WH/BU, WH/OG, WH/GN, WH/BN

Certificates and approvals

Link performance: LEONI MegaLine® systems
and other commonly available connector systems
Test certificates: according to DIN 55350-18-4.2.1 or EN 10204
Compliant with LVD (2014/35/EU): **CE**
Compliant with Construction Products Regulation
(EU/305/2011): **CE**

Dimension	Outer Ø approx.	Weight approx.	Copper no.*	CPR class	DoP no.	Sheath colour	Order no.
	mm	kg/km	kg/km				
4P	8.6	75	38	D _{ca} s2 d2 a1	CDESK0000007	● Rape yellow	LKD 7KS8 0026 xxxx
2 x 4P	8.6 x 17.5	153	76	D _{ca} s2 d2 a1	CDESK0000008	● Rape yellow	LKD 7KS8 0028 xxxx

Packaging: xxxx

Standard length: 0100 = 1000 m 0050 = 500 m 0000 = general

* see page 17: Definition of copper no.

MegaLine® Pro 1300

Category 7_A

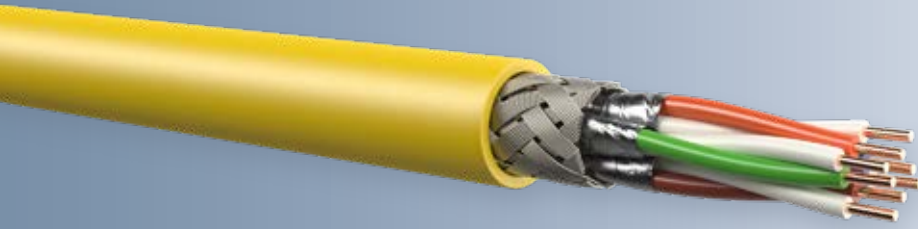

Types **KS-02YSCH 4x2x0,62 mm/~AWG 22/1 PIMF**
KS-02YSCH 4x2x0.62 mm/~AWG 22/1 PIMF

Advantages

- Better than Category 7_A
- bandwidth 1300 MHz
- RoHS and REACh conformity

Construction for 4P

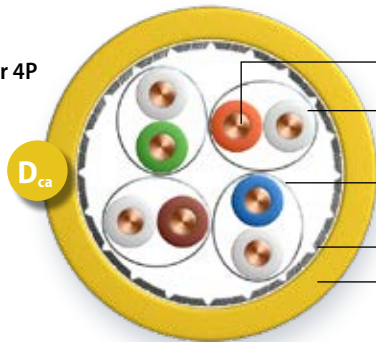

Conductor	Bare copper wire, 0.62mm/~AWG 22/1
Insulation	Cellular PE, core Ø: nominal value 1.5 mm
Twisting element	Pair
Individual shielding	Aluminium bonded polyester foil, metal on the outside (PIMF)
Twisting	4 pairs
Overall shielding	Tinned copper braid
Outer sheath	halogen-free, flame-retardant compound

Fire behaviour

Flame retardancy	acc. to IEC 60332-3-24
Halogen free	acc. to IEC 60754-1/2
Smoke density	acc. to IEC 61034-1/2
Acid formation	acc. to EN 60754-2
Fire load (reference value)	0.74 MJ/m (Sx), 1.5 MJ/m (Dx)
EU Construction Products Regulation	acc. to EN 50575 / EN 50399

Performance

Better than Category 7_A acc. to EN 50288 and IEC 61156, excellent NEXT, low attenuation, excellent shielding characteristics (pairs and overall shielding), low skew, bandwidth (typical) 1300 MHz

Applications

Installation cable for use in structured cabling acc. to ISO/IEC 11801 and EN 50173 (3rd Edition).
 Ideal for all applications of Classes D to F_A, multimedia (TV, video, data, voice) > 10 GbE acc. to IEEE 802.3 an, cable sharing, VoIP, PoE/PoE+.

Mechanical characteristics

Bending radius during installation	8 x outer diameter (min.)
after installation	4 x outer diameter (min.)
Tensile strength (max.)	130 N (Sx), 260 N (Dx)
Crush strength	1000 N/100 mm
Impact strength (number of shocks)	10

Electromagnetic behaviour

Coupling resistance at 10 MHz (nom.)	5 mΩ/m
Shield attenuation up to 1200 MHz (nom.)	70 dB
Coupling attenuation up to 1200 MHz (nom.)	85 dB
Separating class acc. to EN 50174-2	d

Security (fire behaviour)

S	1	2	3	4	5
	IEC 60332-2-2	IEC-60332-1-2	IEC-60332-3-24	EFP Grade 1	EFP Grade 2
		E _{ca} /D _{ca}	E _{ca} /D _{ca}	C _{ca}	B2 _{ca}

Performance (cable class, bandwidth)

P	1	2	3	4	5
	> Class E > 250 MHz	> Class E _A > 500 MHz	> Class F > 600 MHz	> Class F _A > 1000 MHz	> Class F _A + > 1200 MHz

Application (Ethernet, TV)

A	1	2	3	4	5
	> 100 MbE	> 1 GbE	up to 10 GbE	> 10 GbE	> 10 GbE TV

Construction (conductor dimension, tensile strength)

C	1	2	3	4	5
	AWG 27	AWG 26/25	AWG 24	AWG 23	AWG 22

EMC (coupling attenuation)

E	1	2	3	4	5
	> 40 dB	> 50 dB	> 60 dB	> 70 dB	> 80 dB

Electrical characteristics (HF) at 20 °C

Frequency MHz	Attenuation dB/100 m		NEXT dB		PS-NEXT dB		ACR dB at 100 m		PS-ACR dB at 100 m		EL-FEXT dB at 100 m		PS-ELFEXT dB at 100 m		RL dB	
	typ.	Cat. 7 _A max.*	typ.	Cat. 7 _A min.*	typ.	Cat. 7 _A min.*	typ.	Cat. 7 _A min.*	typ.	Cat. 7 _A min.*	typ.	Cat. 7 _A min.*	typ.	Cat. 7 _A min.*	typ.	Cat. 7 _A min.*
1	1.8	2.1	105	78	102	75	104	75.9	101	72.9	105	78	102	75	32.6	20
10	4.7	5.8	105	78	102	75	101	72.2	98	69.2	108	75.3	105	72.3	31.5	25
100	15.9	18.5	105	75.4	102	72.4	89	56.9	86	53.9	93	55.3	90	52.3	29.0	20.1
200	23.5	26.5	105	70.9	102	67.9	81	44.4	78	41.4	85	49.3	82	46.3	25.4	18
250	26.6	29.7	105	69.4	102	66.4	79	39.7	76	36.7	82	47.3	79	44.3	24.1	17.3
500	37	42.8	100	64.9	97	61.9	63	22.2	60	19.2	70	41.3	67	38.3	21.6	17.3
600	41.8	47.1	95	63.7	92	60.7	53	16.6	50	13.6	63	39.7	60	36.7	19.8	17.3
700	45.2	51.1	95	62.7	92	59.7	50	11.6	47	8.6	60	38.4	57	35.4	21.1	16.6
800	48	54.9	93	61.9	90	58.9	45	6.9	42	3.9	57	37.2	54	34.2	21.0	16.1
900	52.3	58.5	90	61.1	87	58.1	38	2.6	35	-0.4	53	36.2	50	33.2	20.0	15.5
1000	55.2	61.9	88	60.4	85	57.4	33	-1.5	30	-4.5	48	35.3	45	32.3	20.0	15.1
1100	57.6	-	87	-	84	-	29	-	26	-	44	-	41	-	18.8	-
1300	64.9	-	80	-	77	-	15	-	13	-	39	-	36	-	17.6	-

* EN 50288-9-1 (2013) / IEC 61156-5 (2009)

Electrical characteristics (LF) at 20 °C

Direct current resistance	max.	65 Ω/km
Insulation resistance	min.	5 GΩ x km
Mutual capacitance	approx.	42 pF/m
Capacitive coupling (e)	approx.	1100 pF/km
Signal tempo (c)	approx.	0.80
Propagation delay	approx.	420 ns/100 m
Skew at 100 MHz	approx.	5 ns/100 m
Charact. impedance	at 100 MHz	100 ± 5 Ω
Testing voltage U _{eff}		1000 V
Operating voltage	max.	125 V

Thermal properties

For fixed installation	-20 °C to +60 °C
For mobile operation	0 °C to +50 °C

Chemical characteristics

Free of hazardous substances acc. to RoHS 2011/65/EU

Cable printing for 4P

LEONI MegaLine Pro 1300 "CPR Class" "DoP no."
Made in Germany "Batch number" "Metre marking"

Colour code

WH/BU, WH/OG, WH/GN, WH/BN

Certificates and approvals

Link performance: LEONI MegaLine® systems
and other commonly available connector systems
Test certificates: according to DIN 55350-18-4.2.1 or EN 10204
Compliant with LVD (2014/35/EU): **CE**
Compliant with Construction Products Regulation
(EU/305/2011): **CE**

Dimension	Outer Ø approx.	Weight approx.	Copper no.*	CPR class	DoP no.	Sheath colour	Order no.
	mm	kg/km	kg/km				
4P	7.5	57	35	D _{ca} s2 d2 a1	CDESK0000007	● Rape yellow	LKD 7KS7 0380 xxxx
2 x 4P	8.1 x 16.4	135	76	D _{ca} s2 d2 a1	CDESK0000008	● Rape yellow	LKD 7KS7 0381 xxxx

Packaging: xxxx

Standard length: 0100 = 1000 m 0050 = 500 m 0000 = general

* see page 17: Definition of copper no.

MegaLine® Pro 1200

Category 7A

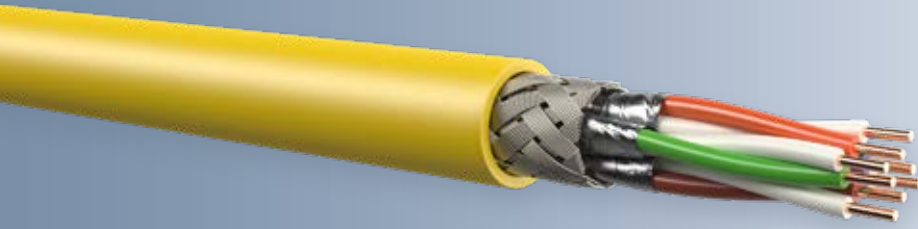

Types **KS-02YSCH 4x2xAWG 23/1 PIMF**
KS-02YSCH 2x(4x2xAWG 23/1 PIMF)

Advantages

- Better than Category 7_A
- bandwidth 1200 MHz
- RoHS and REACh conformity

Construction for 4P

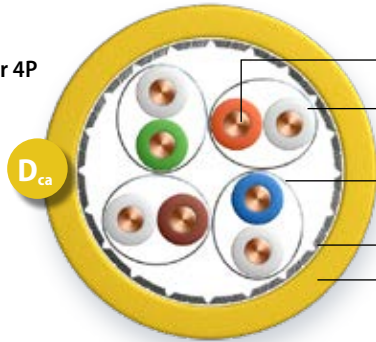

Conductor	Bare copper wire, AWG 23/1
Insulation	Cellular PE, core Ø: nominal value 1.4 mm
Twisting element	Pair
Individual shielding	Aluminium bonded polyester foil, metal on the outside (PIMF)
Twisting	4 pairs
Overall shielding	Tinned copper braid
Outer sheath	halogen-free, flame-retardant compound

Fire behaviour	
Flame retardancy	acc. to IEC 60332-3-24
Halogen free	acc. to IEC 60754-1/2
Smoke density	acc. to IEC 61034-1/2
Acid formation	acc. to EN 60754-2
Fire load (reference value)	0.60 MJ/m (Sx), 1.2 MJ/m (Dx)
EU Construction Products Regulation	acc. to EN 50575 / EN 50399

Performance	
Better than Category 7, acc. to EN 50288 and IEC 61156	
excellent NEXT, excellent shielding characteristics (pairs and overall shielding), low skew, bandwidth (typical) 1200 MHz	

Applications	
Installation cable for use in structured cabling acc. to ISO/IEC 11801 and EN 50173 (3rd Edition).	
Ideal for all applications of Classes D to F _x , multimedia (video, data, voice) > 10 GbE acc. to IEEE 802.3 an, cable sharing, VoIP, PoE/PoE+.	

Mechanical characteristics	
Bending radius during installation	8 x outer diameter (min.)
after installation	4 x outer diameter (min.)
Tensile strength (max.)	110 N (Sx), 220 N (Dx)
Crush strength	1000 N/100 mm
Impact strength (number of shocks)	10

Electromagnetic behaviour	
Coupling resistance at 10 MHz (nom.)	5 mΩ/m
Shield attenuation up to 1000 MHz (nom.)	70 dB
Coupling attenuation up to 1000 MHz (nom.)	85 dB
Separating class acc. to EN 50174-2	d

Security (fire behaviour)

S	1 IEC 60332-2-2	2 IEC-60332-1-2	3 IEC-60332-3-24	4 EFP Grade 1	5 EFP Grade 2
		E _{ca} /D _{ca}	E _{ca} /D _{ca}	C _{ca}	B2 _{ca}

Performance (cable class, bandwidth)

P	1 > Class E > 250 MHz	2 > Class E _x > 500 MHz	3 > Class F > 600 MHz	4 > Class F _x > 1000 MHz	5 > Class F _x + > 1200 MHz
----------	-----------------------------	--	-----------------------------	---	---

Application (ethernet, TV)

A	1 > 100 MbE	2 > 1 GbE	3 up to 10 GbE	4 > 10 GbE	5 > 10 GbE TV
----------	----------------	--------------	-------------------	---------------	------------------

Construction (conductor dimension, tensile strength)

C	1 AWG 27	2 AWG 26/25	3 AWG 24	4 AWG 23	5 AWG 22
----------	-------------	----------------	-------------	-------------	-------------

EMC (coupling attenuation)

E	1 > 40 dB	2 > 50 dB	3 > 60 dB	4 > 70 dB	5 > 80 dB
----------	--------------	--------------	--------------	--------------	--------------

Electrical characteristics (HF) at 20 °C

Frequency MHz	Attenuation dB/100 m		NEXT dB		PS-NEXT dB		ACR dB at 100 m		PS-ACR dB at 100 m		EL-FEXT dB at 100 m		PS-ELFEXT dB at 100 m		RL dB	
	typ.	Cat. 7 _A max.*	typ.	Cat. 7 _A min.*	typ.	Cat. 7 _A min.*	typ.	Cat. 7 _A min.*	typ.	Cat. 7 _A min.*	typ.	Cat. 7 _A min.*	typ.	Cat. 7 _A min.*	typ.	Cat. 7 _A min.*
1	2.0	2.1	105	78.0	102	75.0	103	75.9	100	72.9	98	78	95	75	30	20.0
10	5.3	5.8	100	78.0	97	75.0	95	72.2	92	69.2	98	75.3	95	72.3	29	25.0
100	17.8	18.5	100	75.4	97	72.4	82	56.9	79	53.9	96	55.3	93	52.3	29	20.1
200	24.3	26.5	100	70.9	97	67.9	76	44.4	73	41.4	88	49.3	85	46.3	29	18.0
250	28.5	29.7	100	69.4	97	66.4	72	39.7	69	36.7	84	47.3	81	44.3	27	17.3
500	41.2	42.8	98	64.9	95	61.9	57	22.2	54	19.2	72	41.3	69	38.3	23	15.2
600	45.1	47.1	95	63.7	92	60.7	50	16.6	47	13.6	64	39.7	61	36.7	21	14.7
800	52.5	54.9	93	61.9	90	58.9	41	6.9	38	3.9	58	37.2	55	34.2	20	16.1
1000	59.0	61.9	87	60.4	84	57.4	28	-1.5	25	-4.5	51	35.3	48	32.3	19	15.1
1200	66.3		85	-	82	-	19	-	16	-	42	-	39	-	14	-

* EN 50288-9-1 (2013)/IEC 61156-5 (2009)

Electrical characteristics (LF) at 20 °C

Direct current resistance	max.	75 Ω/km
Insulation resistance	min.	5 GΩ x km
Mutual capacitance	approx.	42 pF/m
Capacitive coupling (e)	approx.	1100 pF/km
Signal tempo (c)	approx.	0.78
Propagation delay	approx.	420 ns/100 m
Skew at 100 MHz	approx.	5 ns/100 m
Charact. impedance	at 100 MHz	100 ± 5 Ω
Testing voltage U _{eff}		1000 V
Operating voltage	max.	125 V

Thermal properties

For fixed installation	-20 °C to +60 °C
For mobile operation	0 °C to +50 °C

Chemical characteristics

Free of hazardous substances acc. to RoHS 2011/65/EU

Cable printing for 4 P

LEONI MegaLine Pro 1200 "CPR Class" "DoP no."
Made in Germany "Batch number" "Metre marking"

Colour code

WH/BU, WH/OG, WH/GN, WH/BN

Certificates and approvals

Link performance: LEONI MegaLine® systems
and other commonly available connector systems
Test certificates: according to DIN 55350-18-4.2.1 or EN 10204
Compliant with LVD (2014/35/EU): **CE**
Compliant with Construction Products Regulation
(EU/305/2011): **CE**

Dimension	Outer Ø approx.	Weight approx.	Copper no.*	CPR class	DoP no.	Sheath colour	Order no.
	mm	kg/km	kg/km				
4P	7.5	57	35	D _{ca} s2 d2 a1	CDESK0000005	● Rape yellow	LKD 7KS7 0311 xxxx
2 x 4P	7.5 x 15.2	117	70	D _{ca} s2 d2 a1	CDESK0000006	● Rape yellow	LKD 7KS7 0312 xxxx

Packaging: xxxx

Standard length: 0100 = 1000 m 0050 = 500 m 0000 = general

* see page 17: Definition of copper no.

MegaLine® Pro 1000

Category 7

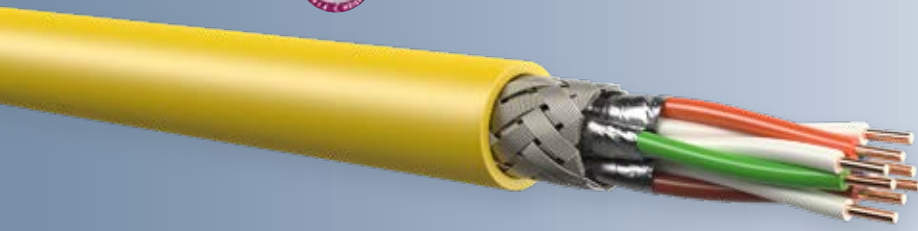

Types **KS-02YSCH 4x2x0,56 mm/~AWG 23/1 PIMF**
KS-02YSCH 2x(4x2x0.56 mm/~AWG 23/1 PIMF)

Advantages

- Better than Category 7
- bandwidth 1000 MHz
- PVP-GHMT
- RoHS and REACh conformity

Construction for 4P

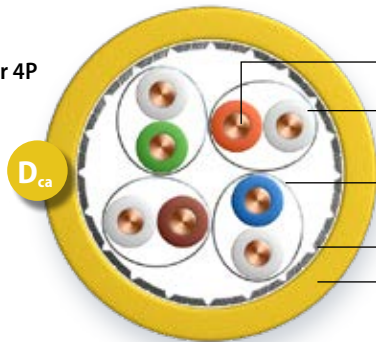

Conductor	Bare copper wire, AWG 23/1
Insulation	Cellular PE, core Ø: nominal value 1.3 mm
Twisting element	Pair
Individual shielding	Aluminium bonded polyester foil, metal on the outside (PiMF)
Twisting	4 pairs
Overall shielding	Tinned copper braid
Outer sheath	halogen-free, flame-retardant compound

Fire behaviour

Flame retardancy	acc. to IEC 60332-3-24/EN 50266-2-4
Halogen free	acc. to IEC 60754-1/2
Smoke density	acc. to IEC 61034-1/2
Acid formation	acc. to EN 60754-2
Fire load (reference value)	0.5 MJ/m (Sx), 1.2 MJ/m (Dx)
EU Construction Products Regulation	acc. to EN 50575 /EN 50399

Performance

Better than Category 7 acc. to EN 50288 and IEC 61156
 excellent NEXT, excellent shielding characteristics (pairs and overall shielding),
 low skew, bandwidth (typical) 1000 MHz

Applications

Installation cable for use in structured cabling acc. to ISO/IEC 11801 and EN 50173 (3rd Edition).
 Ideal for all applications of Classes D to F, multimedia (video, data, voice)
 >10 GbE acc. to IEEE 802.3 an, cable sharing, VoIP, PoE/PoE+.

Mechanical characteristics

Bending radius during installation	8 x outer diameter (min.)
after installation	4 x outer diameter (min.)
Tensile strength (max.)	100 N (Sx), 220 N (Dx)
Crush strength	1000 N/100 mm
Impact strength (number of shocks)	10

Electromagnetic behaviour

Coupling resistance at 10 MHz (nom.)	5 mΩ/m
Shield attenuation up to 1000 MHz (nom.)	70 dB
Coupling attenuation up to 1000 MHz (nom.)	85 dB
Separating class acc. to EN 50174-2	d

Security (fire behaviour)

S	1	2	3	4	5
	IEC 60332-2-2	IEC-60332-1-2	IEC-60332-3-24	EFP Grade 1	EFP Grade 2
		E _{ca} /D _{ca}	E _{ca} /D _{ca}	C _{ca}	B2 _{ca}

Performance (cable class, bandwidth)

P	1	2	3	4	5
	> Class E > 250 MHz	> Class E _A > 500 MHz	> Class F > 600 MHz	> Class F _A > 1000 MHz	> Class F _{A+} > 1200 MHz

Application (ethernet, TV)

A	1	2	3	4	5
	> 100 MbE	> 1 GbE	up to 10 GbE	> 10 GbE	> 10 GbE TV

Construction (conductor dimension, tensile strength)

C	1	2	3	4	5
	AWG 27	AWG 26/25	AWG 24	AWG 23	AWG 22

EMC (coupling attenuation)

E	1	2	3	4	5
	> 40 dB	> 50 dB	> 60 dB	> 70 dB	> 80 dB

Electrical characteristics (HF) at 20 °C

Frequency MHz	Attenuation dB/100 m		NEXT dB		PS-NEXT dB		ACR dB at 100 m		PS-ACR dB at 100 m		EL-FEXT dB at 100 m		PS-ELFEXT dB at 100 m		RL dB	
	typ.	Cat. 7 max.*	typ.	Cat. 7 min.*	typ.	Cat. 7 min.*	typ.	Cat. 7 min.*	typ.	Cat. 7 min.*	typ.	Cat. 7 min.*	typ.	Cat. 7 min.*	typ.	Cat. 7 min.*
1	1.95	2	100	80	97	77	98	78	95	75	100	80	97	77	27	23
10	5.5	5.7	100	80	97	77	94	74	91	71	100	74	97	71	30	25
100	18.4	18.5	100	72	97	69	81	54	78	51	86	54	83	51	25	20.1
200	26.3	26.8	90	68	87	65	63	41	60	38	81	48	78	45	21	18
250	29.4	30.2	90	66	87	63	60	36	57	33	72	46	69	43	33.4	17.3
500	42.3	44.1	85	62	82	59	42	18	39	15	60	40	57	37	19	17.3
600	46.3	48.9	85	61	82	58	38	12	35	9	52	38	49	35	18	17.3
1000	64	–	70	–	67	–	6	–	3	–	29	–	26	–	15	–

* EN 50288-4-1 (2014)/IEC 61156-5 (2009)

Electrical characteristics (LF) at 20 °C

Direct current resistance	max.	78 Ω/km
Insulation resistance	min.	5 GΩ x km
Mutual capacitance	approx.	40 pF/m
Capacitive coupling (e)	approx.	1100 pF/km
Signal tempo (c)	approx.	0.80
Propagation delay	approx.	400 ns/100 m
Skew at 100 MHz	approx.	5 ns/100 m
Charact. impedance	at 100 MHz	100 ± 5 Ω
Testing voltage U _{eff}		1000 V
Operating voltage	max.	125 V

Thermal properties

For fixed installation	–20 °C to +60 °C
For mobile operation	0 °C to +50 °C

Chemical characteristics

Free of hazardous substances acc. to RoHS 2011/65/EU



Cable printing for 4 P

LEONI MegaLine Pro 1000 "CPR Class" "DoP no."
Made in Germany "Batch number" "Metre marking"

Colour code

WH/BU, WH/OG, WH/GN, WH/BN

Certificates and approvals

Quality mark with production control: GHMT PVP
Link performance: LEONI MegaLine® systems
and other commonly available connector systems
Test certificates: according to DIN 55350-18-4.2.1 or EN 10204
Compliant with LVD (2014/35/EU): 
Compliant with Construction Products Regulation
(EU/305/2011): 

Dimension	Outer Ø approx.	Weight approx.	Copper no.*	CPR class	DoP no.	Sheath colour	Order no.
	mm	kg/km	kg/km				
4P	7.4	56	32	D _{ca} s2 d2 a1	CDESK0000005	● Rape yellow	LKD 7KS7 0305 xxxx
2 x 4P	7.4 x 14.8	112	64	D _{ca} s2 d2 a1	CDESK0000006	● Rape yellow	LKD 7KS7 0308 xxxx

Packaging: xxxx

Standard length: 0100 = 1000 m 0050 = 500 m 0000 = general

* see page 17: Definition of copper no.

MegaLine® G20 S/F flex

Category 8.2



Type KS-02YSCH 4x2xAWG 26/7 PIMF

Advantages

- Data center cabling
- better than Cat. 8.2
- bandwidth 2000 MHz
- excellent shielding characteristics
- VDE certified
- RoHS and REACh conformity

Construction for 4P

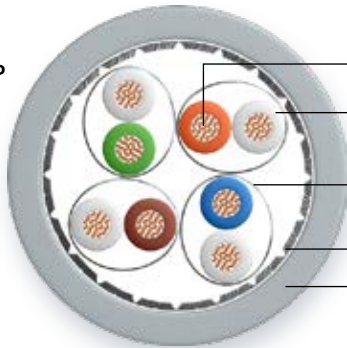

Conductor	Bare stranded copper wire, AWG26/7
Insulation	Cellular PE, core-diameter: max. 1.05 mm
Twisting element	Pair
Individual shielding	Aluminium bonded polyester foil, metal on the outside (PiMF)
Twisting	4 pairs
Overall shielding	Tinned copper braid
Outer sheath	halogen-free, flame-retardant compound

Fire behaviour

Flame retardancy	acc. to IEC 60332-1-2
Halogen free	acc. to IEC 60754-1/2
Smoke density	acc. to IEC 61034-1/2
Fire load (reference value)	0.38 MJ/m
EU Construction Products Regulation	acc. to EN 50575 / EN 50399

Performance

Better than Category 8.2 acc. to draft IEC 61156-10 excellent NEXT, low attenuation, excellent shielding characteristics (pairs and overall shielding), low skew, bandwidth (typical) 2000 MHz

Applications

Connection cable and patch cord for use in structured cabling acc. to ISO/IEC 11801 and EN 50173 (2nd Edition) and for data center cabling acc. to ISO/IEC 24764 and EN 50173-5, as well as PDTR 11801-99-9901. Ideal for all applications of Classes D to F_A and Class II, multimedia (TV, video, data, voice) > 40 GbE acc. to IEEE 802.3 bq (draft), cable sharing, VoIP, PoE/PoE+.

Mechanical characteristics

Bending radius	in operation	5 x outer diameter (min.)
Tensile strength (max.)		60 N

Electromagnetic behaviour

Coupling resistance at 10 MHz (nom.)	5 mΩ/m
Shield attenuation up to 1000 MHz (nom.)	60 dB
Coupling attenuation up to 1000 MHz (nom.)	85 dB
Separating class acc. to EN 50174-2	d

Security (fire behaviour)

S	1 IEC 60332-2-2	2 IEC-60332-1-2	3 IEC-60332-3-24	4 EFP Grade 1	5 EFP Grade 2
		E _{ca} /D _{ca}	E _{ca} /D _{ca}	C _{ca}	B2 _{ca}

Performance (cable class, bandwidth)

P	1 > Class E > 250 MHz	2 > Class E _A > 500 MHz	3 > Class F > 600 MHz	4 > Class F _A > 1000 MHz	5 > Class F _A + > 1200 MHz
----------	-----------------------------	--	-----------------------------	---	---

Application (ethernet, TV)

A	1 > 100 MbE	2 > 1 GbE	3 up to 10 GbE	4 > 10 GbE	5 > 10 GbE TV
----------	----------------	--------------	-------------------	---------------	---------------------

Construction (conductor dimension, tensile strength)

C	1 AWG 27	2 AWG 26/25	3 AWG 24	4 AWG 23	5 AWG 22
----------	-------------	----------------	-------------	-------------	-------------

EMC (coupling attenuation)

E	1 > 40 dB	2 > 50 dB	3 > 60 dB	4 > 70 dB	5 > 80 dB
----------	--------------	--------------	--------------	--------------	--------------

Electrical characteristics (HF) at 20 °C

Frequency MHz	Attenuation dB/50 m		NEXT dB		PS-NEXT dB		ACR dB at 30 m		PS-ACR dB at 30 m		EL-FEXT dB		PS-ELFEXT dB		RL dB	
	typ.	Cat. 8.2 max.*	typ.	Cat. 8.2 min.*	typ.	Cat. 8.2 min.*	typ.	Cat. 8.2 min.*	typ.	Cat. 8.2 min.*	typ.	Cat. 8.2 min.*	typ.	Cat. 8.2 min.*	typ.	Cat. 8.2 min.*
10	1.7	2.6	100.0	90.4	97	87.4	98	87.8	95	84.8	95	80.8	92	77.8	28.4	25.0
100	6.4	8.3	100.0	75.4	97	72.4	94	67.1	91	64.1	95	60.8	92	57.8	31.2	22.2
250	10.3	13.4	100.0	69.4	97	66.4	90	56.1	87	53.1	90	52.8	87	49.8	28.4	19.4
500	15.0	19.2	94	64.9	91	61.9	79	45.7	76	42.7	84	46.8	81	43.8	25.6	17.3
600	16.4	21.2	93	63.7	90	60.7	77	42.5	74	39.5	82	45.2	79	42.2	24.7	16.8
1000	21.2	27.9	77	60.4	74	57.4	56	32.5	53	29.5	66	40.8	63	37.8	17.5	15.2
1200	23.2	30.8	72	59.2	69	56.2	49	28.4	46	25.4	61	39.2	58	36.2	17.1	14.7
1500	26.1	34.7	72	57.8	69	54.8	45	23.0	42	20.0	56	37.3	53	34.3	16.1	14.0
1600	27.4	36.0	72	57.3	69	54.3	44	21.3	41	18.3	55	36.7	52	33.7	15.8	13.8
1700	28.6	37.2	71	56.9	68	53.9	43	19.7	40	16.7	53	36.2	50	33.2	14.2	13.6
1800	29.3	38.4	66	56.6	63	53.6	37	18.2	34	15.2	53	35.7	50	32.7	14.0	13.4
1900	30.4	39.6	65	56.2	62	53.2	35	16.6	32	13.6	46	35.2	43	32.2	13.8	13.3
2000	31.4	40.7	63	55.9	60	52.9	32	15.2	29	12.2	43	34.8	40	31.8	13.5	13.1

* IEC 61156-10 (2016). If IO FEXT is min. 90 dB to 1000 MHz and min. 80 dB to 2,000 MHz, EL-FEXT is fulfilled by design.

Electrical characteristics (LF) at 20 °C

Direct current resistance	max.	145 Ω/km
Insulation resistance	min.	5 GΩ x km
Mutual capacitance	approx.	43 pF/m
Signal tempo (c)	approx.	0.78
Propagation delay	approx.	430 ns/100 m
Skew at 100 MHz	approx.	5 ns/100 m
Charact. impedance	at 100 MHz	100 ± 5 Ω
Testing voltage U _{eff}		1000 V
Operating voltage	max.	125 V

Thermal properties

For fixed installation	-20 °C to +60 °C
For mobile operation	0 °C to +50 °C

Chemical characteristics

Free of hazardous substances acc. to RoHS 2011/65/EU

Cable printing

LEONI MegaLine G20 S/F flex 4P H SPACE Code "xxxxx"
 "CPR Class" "DoP no." "VDE mark" Made in Germany
 "Batch number" "Metre marking"

Colour code

WH/BU, WH/OG, WH/GN, WH/BN

Certificates and approvals

Quality mark with production control: <VDE>

Link performance: LEONI MegaLine® systems

and other commonly available connector systems

Test certificates: according to DIN 55350-18-4.2.1 or EN 10204

Compliant with LVD (2014/35/EU): 

Compliant with Construction Products Regulation
 (EU/305/2011): 

Dimension	Outer Ø approx.	Weight approx.	Copper no.*	CPR class	DoP no.	Sheath colour	Order no.
	mm	kg/km	kg/km				
4P	5.8	41	23.5	D _{ca} s2 d2 a1	CDESK0000023	● Light grey	LKD 7KS8 0013 xxxx

Packaging: xxxx

Standard length: 0100 = 1000 m 0050 = 500 m 0000 = general

* see page 17: Definition of copper no.

MegaLine® F10-120 S/F flex

Category 7



Advantages

- Better than Category 7
- bandwidth 1200 MHz
- excellent shielding characteristics
- VDE certified
- RoHS and REACH conformity

Types KS-02YSCH 4x2xAWG 26/7 PIMF

Construction for 4P

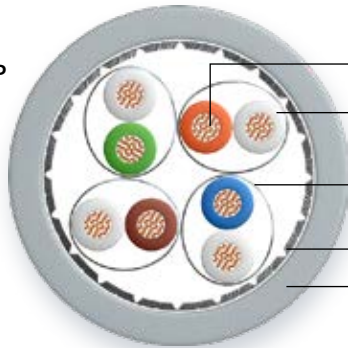

Conductor	Bare stranded copper wire, AWG26/7
Insulation	Cellular PE, core-diameter: max. 1.05 mm
Twisting element	Pair
Individual shielding	Aluminium bonded polyester foil, metal on the outside (PiMF)
Twisting	4 pairs
Overall shielding	Tinned copper braid
Outer sheath	halogen-free, flame-retardant compound

Fire behaviour

Flame retardancy	acc. to IEC 60332-1-2
Halogen free	acc. to IEC 60754-1/2
Smoke density	acc. to IEC 61034-1/2
Fire load (reference value)	0.38 MJ/m (Sx)
EU Construction Products Regulation	acc. to EN 50575 / EN 50399

Performance

Better than Category 7 acc. to EN 50288 and IEC 61156
excellent NEXT, low attenuation, excellent shielding characteristics
(pairs and overall shielding), low skew, bandwidth (typical) 1200 MHz

Applications

Collection point, connection cables and patch cords for use in structured cabling acc. to ISO/IEC 11801 and EN 50173 (3rd Edition), as well as ISO/IEC 24764 and EN 50173-5.

Ideal for all applications of Classes D to F₊, multimedia (TV, video, data voice) > 10 GbE acc. to IEEE 802.3 an, cable sharing, VoIP, PoE/PoE+.

Mechanical characteristics

Bending radius	in operation	5 x outer diameter (min.)
Tensile strength (max.)		60 N (Sx), 400 N (8-fold)

Electromagnetic behaviour

Coupling resistance at 10 MHz (nom.)	5 mΩ/m
Shield attenuation up to 1000 MHz (nom.)	60 dB
Coupling attenuation up to 1000 MHz (nom.)	85 dB
Separating class acc. to EN 50174-2	d

Security (fire behaviour)

S	1 IEC 60332-2-2	2 IEC-60332-1-2	3 IEC-60332-3-24	4 EFP Grade 1	5 EFP Grade 2
		E _{ca} /D _{ca}	E _{ca} /D _{ca}	C _{ca}	B2 _{ca}

Performance (cable class, bandwidth)

P	1 > Class E > 250 MHz	2 > Class E ₁ > 500 MHz	3 > Class F > 600 MHz	4 > Class F ₁ > 1000 MHz	5 > Class F ₁₊ > 1200 MHz
----------	-----------------------------	--	-----------------------------	---	--

Application (ethernet, TV)

A	1 > 100 MbE	2 > 1 GbE	3 up to 10 GbE	4 > 10 GbE	5 > 10 GbE TV
----------	----------------	--------------	-------------------	---------------	---------------------

Construction (conductor dimension, tensile strength)

C	1 AWG 27	2 AWG 26/25	3 AWG 24	4 AWG 23	5 AWG 22
----------	-------------	----------------	-------------	-------------	-------------

EMC (coupling attenuation)

E	1 > 40 dB	2 > 50 dB	3 > 60 dB	4 > 70 dB	5 > 80 dB
----------	--------------	--------------	--------------	--------------	--------------

Electrical characteristics (HF) at 20 °C

Frequency MHz	Attenuation dB/10m		NEXT dB		PS-NEXT dB		ACR dB at 10m		PS-ACR dB at 10m		EL-FEXT dB at 10m		PS-ELFEXT dB at 10m		RL dB	
	typ.	Cat. 7 max.*	typ.	Cat. 7 min.*	typ.	Cat. 7 min.*	typ.	Cat. 7 min.*	typ.	Cat. 7 min.*	typ.	Cat. 7 min.*	typ.	Cat. 7 min.*	typ.	Cat. 7 min.*
1	0.25	0.29	100	80	97	77	100	80	97	77	100	80	97	77	24	23
10	0.76	0.85	99	80	96	77	99	79	96	77	95	74	92	71	33.9	25
100	2.49	2.78	95	78	92	75	93	75	90	72	69	54	66	51	38.3	20.1
200	3.69	3.97	92	74	89	71	88	70	85	67	65	48	62	45	35.3	18
250	4.18	4.46	90	72	87	69	86	68	83	65	62	46	59	43	32.9	17.3
500	5.6	6.41	83	68	80	65	78	62	75	59	54	40	51	37	29.7	17.3
600	6.74	7.06	81	67	78	64	74	60	71	57	50	38	47	35	30.6	17.3
700	7.32	7.67	80	66	77	63	72	58	69	55	50	37	47	34	31	15
800	7.89	8.24	77	65	74	62	69	57	66	54	50	36	47	33	26.7	14.5
900	8.5	8.78	75	64	72	61	67	55	64	52	36	35	33	32	28.6	14.1
1000	9.11	9.29	74	63.4	71	60	65	54	62	51	35	34	32	31	27.5	13.7
1100	9.5	-	72	-	69	-	63	-	60	-	28	-	25	-	26.9	-
1200	9.9	-	70	-	67	-	61	-	58	-	24	-	21	-	26.3	-

* EN 50288-9-2 (2015)/IEC 61156-6 (2010)

Electrical characteristics (LF) at 20 °C

Direct current resistance	max.	145 Ω/km
Insulation resistance	min.	5 GΩ x km
Mutual capacitance	approx.	44 pF/m
Signal tempo (c)	approx.	0.78
Propagation delay	approx.	440 ns/100 m
Skew at 100 MHz	approx.	2.5 ns/100 m
Charact. impedance	at 100 MHz	100 ± 5 Ω
Testing voltage U _{eff}		1000 V
Operating voltage	max.	125 V

Thermal properties

For fixed installation	-20 °C to +60 °C
For mobile operation	0 °C to +50 °C

Chemical characteristics

Free of hazardous substances acc. to RoHS 2011/65/EU

Cable printing for 4 P

LEONI MegaLine F10-120 S/F flex 4P H SPACE Code "xxxxx"
 "CPR Class" "DoP no." "VDE mark" Made in Germany
 "Batch number" "Metre marking"

Colour code

WH/BU, WH/OG, WH/GN, WH/BN

Certificates and approvals

Quality mark with production control: <VDE>

Link performance: LEONI MegaLine® systems

and other commonly available connector systems

Test certificates: according to DIN 55350-18-4.2.1 or EN 10204

Compliant with LVD (2014/35/EU): **CE**

Compliant with Construction Products Regulation

(EU/305/2011): **CE**

Dimension	Outer Ø approx.	Weight approx.	Copper no.*	CPR class	DoP no.	Sheath colour	Order no.
	mm	kg/km	kg/km				
4P	5.8	41	23.5	D _{ca} s2 d2 a1	CDESK0000023	● Light grey	LKD 7KS7 0003 xxxx

Packaging: xxxx

Standard length: 0100 = 1000 m 0050 = 500 m 0000 = general

* see page 17: Definition of copper no.

MegaLine® F6-90 S/F flex

Category 7



Type KS-02YSCH 4x2xAWG 27/7 PIMF

Advantages

- Better than Category 7
- bandwidth 900 MHz
- excellent shielding characteristics
- VDE certified
- RoHS and REACH conformity

Construction for 4P

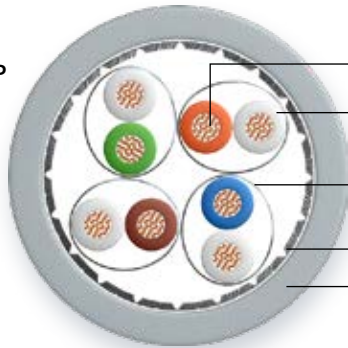

Conductor	Bare stranded copper wire, AWG27/7
Insulation	Cellular PE, core-diameter: max. 1.0 mm
Twisting element	Pair
Individual shielding	Aluminium bonded polyester foil, metal on the outside (PiMF)
Twisting	4 pairs
Overall shielding	Tinned copper braid
Outer sheath	halogen-free, flame-retardant compound

Fire behaviour	
Flame retardancy	acc. to IEC 60332-1-2
Halogen free	acc. to IEC 60754-1/2
Smoke density	acc. to IEC 61034-1/2
Fire load (reference value)	0.33 MJ/m
EU Construction Products Regulation	acc. to EN 50575 / EN 50399

Performance	
Better than Category 7 acc. to EN 50288 and IEC 61156	
excellent NEXT, excellent shielding characteristics (pairs and overall shielding), low skew, bandwidth (typical) 900 MHz	

Applications	
Connection cable and patch cord for use in structured cabling acc. to ISO/IEC 11801 and EN 50173 (3rd Edition).	
Ideal for all applications of Classes D to F, multimedia (video, data, voice) > 10 GbE acc. to IEEE 802.3 an, cable sharing, VoIP, PoE/PoE+.	

Mechanical characteristics		
Bending radius	in operation	5 x outer diameter (min.)
Tensile strength (max.)		40 N

Electromagnetic behaviour	
Coupling resistance at 10 MHz (nom.)	5 mΩ/m
Shield attenuation up to 1000 MHz (nom.)	60 dB
Coupling attenuation up to 1000 MHz (nom.)	80 dB
Separating class acc. to EN 50174-2	d

Security (fire behaviour)

S	1 IEC 60332-2-2	2 IEC-60332-1-2	3 IEC-60332-3-24	4 EFP Grade 1	5 EFP Grade 2
		E _{ca} /D _{ca}	E _{ca} /D _{ca}	C _{ca}	B2 _{ca}

Performance (cable class, bandwidth)

P	1 > Class E > 250 MHz	2 > Class E _A > 500 MHz	3 > Class F > 600 MHz	4 > Class F _A > 1000 MHz	5 > Class F _A + > 1200 MHz
----------	-----------------------------	--	-----------------------------	---	---

Application (ethernet, TV)

A	1 > 100 MbE	2 > 1 GbE	3 up to 10 GbE	4 > 10 GbE	5 > 10 GbE TV
----------	----------------	--------------	-------------------	---------------	------------------

Construction (conductor dimension, tensile strength)

C	1 AWG 27	2 AWG 26/25	3 AWG 24	4 AWG 23	5 AWG 22
----------	-------------	----------------	-------------	-------------	-------------

EMC (coupling attenuation)

E	1 > 40 dB	2 > 50 dB	3 > 60 dB	4 > 70 dB	5 > 80 dB
----------	--------------	--------------	--------------	--------------	--------------

Electrical characteristics (HF) at 20 °C

Frequency MHz	Attenuation dB/10m		NEXT dB		PS-NEXT dB		ACR dB at 10m		PS-ACR dB at 10m		EL-FEXT dB at 10m		PS-ELFEXT dB at 10m		RL dB	
	typ.	Cat. 7 max.*	typ.	Cat. 7 min.*	typ.	Cat. 7 min.*	typ.	Cat. 7 min.*	typ.	Cat. 7 min.*	typ.	Cat. 7 min.*	typ.	Cat. 7 min.*	typ.	Cat. 7 min.*
1	0.26	0.29	95	80	92	77	95	80	92	77	92	80	89	80	21.8	-
10	0.83	0.85	94	80	91	77	94	79	91	77	84	74	81	71	29.7	25
100	2.74	2.78	90	72	87	69	88	70	85	69	70	54	67	51	35	20.1
200	3.9	4.01	87	68	84	65	83	64	80	65	60	48	57	45	33	18
250	4.39	4.53	85	66	82	63	81	62	78	63	56	46	53	43	31.6	17.3
500	6.21	6.62	78	62	75	59	72	55	69	59	52	40	49	37	28.8	17.3
600	6.91	7.33	76	61	73	58	69	53	66	58	48	38	45	35	27.1	17.3
700	7.48	-	75	-	72	-	67	-	64	-	34	-	31	-	26.4	-
800	8.06	-	72	-	69	-	64	-	61	-	34	-	31	-	24.7	-
900	8.62	-	70	-	67	-	62	-	59	-	11	-	8	-	24.4	-

* EN 50288-4-2 (2014)/IEC 61156-6 (2010)

Electrical characteristics (LF) at 20 °C

Direct current resistance	max.	170 Ω/km
Insulation resistance	min.	5 GΩ x km
Mutual capacitance	approx.	44 pF/m
Signal tempo (c)	approx.	0.78
Propagation delay	approx.	430 ns/100 m
Skew at 100 MHz	approx.	2.5 ns/100 m
Charact. impedance	at 100 MHz	100 ± 5 Ω
Testing voltage U _{eff}		1000 V
Operating voltage	max.	125 V

Thermal properties

For fixed installation	-20 °C to +60 °C
For mobile operation	0 °C to +50 °C

Chemical characteristics

Free of hazardous substances acc. to RoHS 2011/65/EU

Cable printing

LEONI MegaLine F6-90 S/F flex 4P H SPACE Code "xxxxx"
 "CPR Class" "DoP no." "VDE mark" "Made in Germany" "Batch
 number" "Metre marking"

Colour code

WH/BU, WH/OG, WH/GN, WH/BN

Certificates and approvals

Quality mark with production control: <VDE>

Link performance: LEONI MegaLine® systems





and other commonly available connector systems

Test certificates: according to DIN 55350-18-4.2.1 or EN 10204

Compliant with LVD (2014/35/EU): 

Compliant with Construction Products

Regulation (EU/305/2011): 

Dimension	Outer Ø approx.	Weight approx.	Copper no.*	CPR class	DoP no.	Sheath colour	Order no.
	mm	kg/km	kg/km				
4P	5.7	34	17	D _{ca} s2 d2 a1	CDESK0000022	 Light grey	LKD 7KS7 0014 xxxx
						 Rape yellow	LKD 7KS7 0015 xxxx
						 Turquoise green	LKD 7KS7 0016 xxxx
						 Sky blue	LKD 7KS7 0017 xxxx
						 Fire red	LKD 7KS7 0018 xxxx

Packaging: xxxx

Standard length: 0100 = 1000 m 0050 = 500 m 0000 = general

* see page 17: Definition of copper no.

MegaLine® D1-20 SF/U flex

Category 5

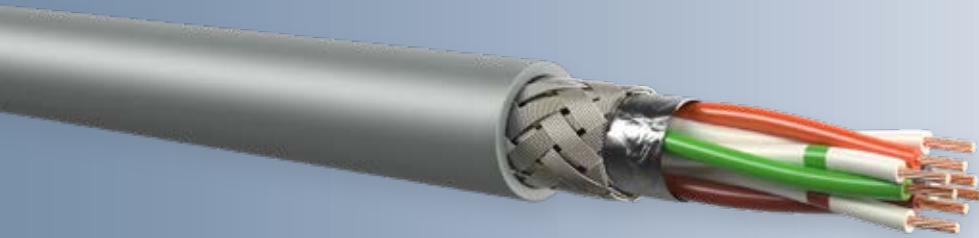

Type KS-02YS(ST+C)Y 4x2xAWG 26/7

Advantages

- Better than Category 5
- bandwidth 200 MHz
- good shielding characteristics
- RoHS and REACh conformity

Construction for 4P

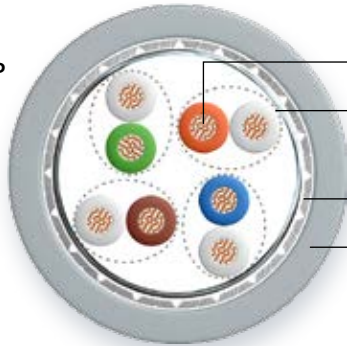

Conductor	bare copper wire, AWG 26/7
Insulation	Cellular PE, core-diameter: max. 1.0 mm
Twisting element	Pair
Twisting	4 pairs
Overall shielding	Aluminium bonded polyester foil and Tinned copper braid
Outer sheath	PVC

Fire behaviour	
Flame retardancy	acc. to IEC 60332-1-2
Fire load (reference value)	0.4 MJ/m

Performance	
Better than Category 5 acc. to EN 50288 and IEC 61156 excellent shielding characteristics bandwidth (typical) 200 MHz	

Applications	
Connection cable and patch cord for use in structured cabling acc. to ISO/IEC 11801 and EN 50173 (3rd Edition).	
Ideal for all applications of Classes D up to 1 GbE acc. to IEEE 802.3 ab, VoIP, PoE/PoE+	

Mechanical characteristics	
Bending radius	in operation 5 x outer diameter (min.)
Tensile strength (max.)	60 N

Electromagnetic behaviour	
Coupling resistance at 10 MHz (nom.)	10 mΩ/m
Shield attenuation up to 1000 MHz (nom.)	50 dB
Coupling attenuation up to 1000 MHz (nom.)	65 dB
Separating class acc. to EN 50174-2	c

Security (fire behaviour)

S	1	2	3	4	5
	IEC 60332-2-2	IEC-60332-1-2	IEC-60332-3-24	EFP Grade 1	EFP Grade 2

Performance (cable class, bandwidth)

P	1	2	3	4	5
	> Class E > 250 MHz	> Class E _A > 500 MHz	> Class F > 600 MHz	> Class F _A > 1000 MHz	> Class F _{A+} > 1200 MHz

Application (ethernet, TV)

A	1	2	3	4	5
	> 100 MbE	> 1 GbE	up to 10 GbE	> 10 GbE	> 10 GbE TV

Construction (conductor dimension, tensile strength)

C	1	2	3	4	5
	AWG 27	AWG 26/25	AWG 24	AWG 23	AWG 22

EMC (coupling attenuation)

E	1	2	3	4	5
	> 40 dB	> 50 dB	> 60 dB	> 70 dB	> 80 dB

Electrical characteristics (HF) at 20 °C

Frequency MHz	Attenuation dB/10m		NEXT dB		PS-NEXT dB		ACR dB at 10m		PS-ACR dB at 10m		EL-FEXT dB at 10m		PS-ELFEXT dB at 10m		RL dB	
	typ.	Cat. 5 max.*	typ.	Cat. 5 min.*	typ.	Cat. 5 min.*	typ.	Cat. 5 min.*	typ.	Cat. 5 min.*	typ.	Cat. 5 min.*	typ.	Cat. 5 min.*	typ.	Cat. 5 min.*
1	0.24	0.32	76	65	73	62	76	65	73	62	91	64	88	61	24.9	-
4	0.44	0.60	71	56	68	53	70	56	67	53	76	52	73	49	29.8	23
10	0.80	0.95	64	50	61	47	63	49	60	47	68	44	65	41	38.2	25
16	1.01	1.21	60	47	57	44	59	46	56	44	64	40	61	37	39.3	25
31.25	1.44	1.71	56	43	53	40	54	41	51	40	58	34	55	31	36.7	23.6
62.5	2.07	2.48	52	38	49	35	50	36	47	35	52	28	49	25	35	21.5
100	2.66	3.2	48	35	45	32	45	32	42	32	47	24	44	21	29.9	20.1
155	3.26	-	45	-	42	-	42	-	39	-	42	-	39	-	26.2	-
200	3.86	-	42	-	39	-	39	-	36	-	37	-	34	-	23.5	-

* EN 50288-2-2 (2014)/IEC 61156-6 (2010)

Electrical characteristics (LF) at 20 °C

Direct current resistance	max.	145 Ω/km
Insulation resistance	min.	5 GΩ x km
Mutual capacitance	approx.	51 pF/m
Signal tempo (c)	approx.	0.65
Propagation delay	approx.	510 ns/100 m
Skew at 100 MHz	approx.	15 ns/100 m
Charact. impedance	at 100 MHz	100 ± 5 Ω
Testing voltage U_{eff}		1000 V
Operating voltage	max.	125 V

Thermal properties

For fixed installation	-20 °C to +60 °C
For mobile operation	0 °C to +50 °C

Chemical characteristics

Free of hazardous substances acc. to RoHS 2011/65/EU

Cable printing

LEONI MegaLine D1-20 SF/U flex 4P Y SPACE Code „xxxxx“
Made in Germany "Batch number" "Metre marking"

Colour code

WH-BU/BU, WH-OG/OG, WH-GN/GN, WH-BN/BN

Certificates and approvals

Link performance: LEONI MegaLine® systems
and other commonly available connector systems
Test certificates: according to DIN 55350-18-4.2.1 or EN 10204
Compliant with LVD (2014/35/EU): **CE**



Dimension	Outer Ø approx.	Weight approx.	Copper no.*	Sheath colour	Order no.
	mm	kg/km	kg/km		
4P	5.5	33	21	● Light grey	LKD 7KS5 0008 xxxx
				● Rape yellow	LKD 7KS5 0009 xxxx
				● Turquoise green	LKD 7KS5 0010 xxxx
				● Sky blue	LKD 7KS5 0011 xxxx
				● Fire red	LKD 7KS5 0012 xxxx

Packaging: xxxx

Standard length: 0100 = 1000 m 0050 = 500 m 0000 = general

* see page 17: Definition of copper no.

MegaLine® F10-130 S/F (L)2Y

Category 7A



Advantages

- Better than Category 7_A
- bandwidth 1300 MHz
- excellent shielding characteristics
- for installation outdoors and in the ground
- VDE certified
- PVP-GHMT
- RoHS and REACH conformity

Type KS-02YSCH(L)2Y 4x2xAWG 22/1 PIMF

Construction for 4P

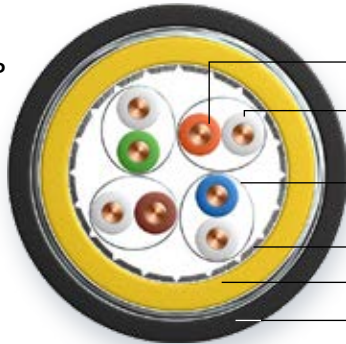

Conductor	Bare copper wire, AWG 22/1
Insulation	Cellular PE, core Ø: nominal value 1.6 mm
Twisting element	Pair
Individual shielding	Aluminium bonded polyester foil, metal on the outside (PiMF)
Twisting	4 pairs
Overall shielding	Tinned copper braid
Inner sheath	halogen-free, flame-retardant compound
Outer sheath	AL-PE

Fire behaviour	
Halogen free	acc. to IEC 60754-1/2
Smoke density	acc. to IEC 61034-1/2
Fire load (reference value)	3.04 MJ/m

Performance	
Better than Category 7 acc. to EN 50288 and IEC 61156	
excellent NEXT, low attenuation, excellent shielding characteristics (pairs and overall shielding), low skew, bandwidth (typical) 1300 MHz	

Applications	
Installation cable for use in structured cabling acc. to ISO/IEC 11801 and EN 50173 (3rd Edition).	
Ideal for all applications of Classes D to F _A , multimedia (video, data voice) > 10 GbE acc. to IEEE 802.3 an, cable sharing, VolP, PoE/PoE+.	
For use outdoors and underground installation.	

Mechanical characteristics	
Bending radius during installation	8 x outer diameter (min.)
after installation	4 x outer diameter (min.)
Tensile strength (max.)	130 N
Crush strength	2000 N/100 mm
Impact strength (number of shocks)	20

Electromagnetic behaviour	
Coupling resistance at 10 MHz (nom.)	5 mΩ/m
Shield attenuation up to 1000 MHz (nom.)	70 dB
Coupling attenuation up to 1000 MHz (nom.)	85 dB
Separating class acc. to EN 50174-2	d

Security (fire behaviour)

S	1	2	3	4	5
	IEC 60332-2-2	IEC-60332-1-2	IEC-60332-3-24	EFP Grade 1	EFP Grade 2

Performance (cable class, bandwidth)

P	1	2	3	4	5
	> Class E > 250 MHz	> Class E _A > 500 MHz	> Class F > 600 MHz	> Class F _A > 1000 MHz	> Class F _A + > 1200 MHz

Industrial application (ethernet, TV)

I	1	2	3	4	5
	> 100 MbE	> 1 GbE	up to 10 GbE	> 10 GbE	> 10 GbE TV

Construction (conductor dimension, tensile strength)

C	1	2	3	4	5
	AWG 27	AWG 26/25	AWG 24	AWG 23	AWG 22

EMC (coupling attenuation)

E	1	2	3	4	5
	> 40 dB	> 50 dB	> 60 dB	> 70 dB	> 80 dB

Electrical characteristics (HF) at 20 °C

Frequency MHz	Attenuation dB/100 m		NEXT dB		PS-NEXT dB		ACR dB at 100 m		PS-ACR dB at 100 m		EL-FEXT dB at 100 m		PS-ELFEXT dB at 100 m		RL dB	
	typ.	Cat. 7 max.*	typ.	Cat. 7 max.*	typ.	Cat. 7 max.*	typ.	Cat. 7 max.*	typ.	Cat. 7 max.*	typ.	Cat. 7 max.*	typ.	Cat. 7 max.*	typ.	Cat. 7 max.*
1	1.7	2	105	80	102	77	104	78	101	75	105	80	102	77	27.1	23
10	4.5	5.7	105	80	102	77	101	74	98	71	108	74	105	71	35.2	25
100	15.4	18.5	105	72	102	69	90	54	87	51	93	54	90	51	38.9	20.1
200	22.9	26.8	105	68	102	65	83	41	80	38	85	48	82	45	36.6	18
250	26	30.2	105	66	102	63	79	36	76	33	82	46	79	43	35.3	17.3
500	35.9	44.1	100	62	97	59	64	18	61	15	70	40	67	37	29.4	17.3
600	40.4	48.9	95	61	92	58	55	12	52	9	63	38	60	35	26.6	17.3
700	44.6	-	95	-	92	-	50	-	47	-	60	-	57	-	25.8	-
800	47.7	-	93	-	90	-	45	-	42	-	57	-	54	-	25	-
900	51.6	-	90	-	87	-	38	-	35	-	53	-	50	-	23.6	-
1000	54.8	-	88	-	85	-	33	-	30	-	48	-	45	-	22.3	-
1100	56.9	-	87	-	84	-	30	-	27	-	44	-	41	-	21.4	-
1300	61.4	-	80	-	77	-	21	-	18	-	39	-	36	-	18.3	-

* EN 50288-4-1 (2014)/IEC 61156-5 (2009)

Electrical characteristics (LF) at 20 °C

Direct current resistance	max.	57.1 Ω/km
Insulation resistance	min.	5 GΩ x km
Mutual capacitance	approx.	40 pF/m
Capacitive coupling (e)	approx.	1100 pF/km
Signal tempo (c)	approx.	0.80
Propagation delay	approx.	420 ns/100 m
Skew at 100 MHz	approx.	5 ns/100 m
Charact. impedance	at 100 MHz	100 ± 5 Ω
Testing voltage U _{eff}		1000 V
Operating voltage	max.	125 V

Thermal properties

For fixed installation	-25 °C to +70 °C
For mobile operation	-10 °C bis +50 °C

Chemical characteristics

Free of hazardous substances acc. to RoHS 2011/65/EU
UV resistance according to UL 1581 and ISO 4892

Cable printing

Inner sheath >>

LEONI MegaLine F10-130 S/F 4P H SPACE Code "xxxxx"
"CPR Class" "DoP no." "VDE mark" Made in Germany
"Batch number" "Metre marking"

Outer sheath >>

LEONI MegaLine F10-130 S/F 4P H(L)2Y SPICE Code "xxxxx" Made
in Germany "Batch number" "Metre marking"

Colour code

WH/BU, WH/OG, WH/GN, WH/BN

Certificates and approvals

Quality mark with production control:

<VDE>, GHMT PVP

Link performance: LEONI MegaLine® systems

and other commonly available connector systems

Test certificates: according to DIN 55350-18-4.2.1 or EN 10204

Compliant with LVD (2014/35/EU): 

Dimension	Outer Ø approx.	Weight approx.	Copper no.*	Sheath colour	Order no.
	mm	kg/km	kg/km		
4P	12.0	150	45	● Jet black	LKD 7K57 002U xxxx

Packaging: xxxx

Standard length: 0100 = 1000 m 0000 = general

* see page 17: Definition of copper no.

MegaLine® F10-130 S/F QH

Category 7A



Type KS-02YSCHQH 4x2xAWG 22/1 PIMF

Advantages

- Better than Category 7_A
- bandwidth 1300 MHz
- excellent shielding characteristics
- for installation in outdoor areas and in harsh environments
- VDE certified
- PVP-GHMT
- RoHS and REACH conformity

Construction for 4P

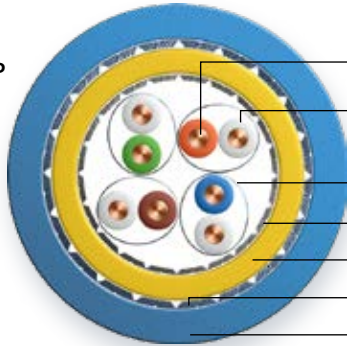

Conductor	Bare copper wire, AWG 22/1
Insulation	Cellular PE, core Ø: nominal value 1.6 mm
Twisting element	Pair
Individual shielding	Aluminium bonded polyester foil, metal on the outside (PiMF)
Twisting	4 pairs
Overall shielding	Tinned copper braid
Inner sheath	halogen-free, flame-retardant compound
Armour	Galvanised steel wire braiding
Outer sheath	halogen-free, flame-retardant compound

Fire behaviour

Flame retardancy	acc. to IEC 60332-3-24
Halogen free	acc. to IEC 60754-1/2
Smoke density	acc. to IEC 61034-1/2
Fire load (reference value)	1.53 MJ/m

Performance

Better than Category 7 acc. to EN 50288 and IEC 61156
excellent NEXT, low attenuation, excellent shielding characteristics (pairs and overall shielding), low skew, bandwidth (typical) 1300 MHz

Applications

Installation cable for use in structured cabling acc. to ISO/IEC 11801 and EN 50173 (3rd Edition). Ideal for all applications of Classes D to F_A, **multimedia** (video, data, voice) > 10 GbE acc. to IEEE 802.3 an, cable sharing, VoIP, PoE/PoE+. For use indoors and outdoors (conditionally) and in harsh environments. With rodent protection.

Mechanical characteristics

Bending radius during installation	8 x outer diameter (min.)
after installation	4 x outer diameter (min.)
Tensile strength (max.)	1400 N
Crush strength	3000 N/100 mm
Impact strength (number of shocks)	50

Electromagnetic behaviour

Coupling resistance at 10 MHz (nom.)	5 mΩ/m
Shield attenuation up to 1000 MHz (nom.)	70 dB
Coupling attenuation up to 1000 MHz (nom.)	85 dB
Separating class acc. to EN 50174-2	d

Security (fire behaviour)

S	1 IEC 60332-2-2	2 IEC-60332-1-2	3 IEC-60332-3-24	4 EFP Grade 1	5 EFP Grade 2
----------	--------------------	--------------------	---------------------	---------------------	---------------------

Performance (cable class, bandwidth)

P	1 > Class E > 250 MHz	2 > Class E _A > 500 MHz	3 > Class F > 600 MHz	4 > Class F _A > 1000 MHz	5 > Class F _A + > 1200 MHz
----------	-----------------------------	--	-----------------------------	---	---

Industrial application (ethernet, TV)

I	1 > 100 MbE	2 > 1 GbE	3 up to 10 GbE	4 > 10 GbE	5 > 10 GbE TV
----------	----------------	--------------	-------------------	---------------	---------------------

Construction (conductor dimension, tensile strength)

C	1 AWG 27	2 AWG 26/25	3 AWG 24	4 AWG 23	5 AWG 22
----------	-------------	----------------	-------------	-------------	-------------

EMC (coupling attenuation)

E	1 > 40 dB	2 > 50 dB	3 > 60 dB	4 > 70 dB	5 > 80 dB
----------	--------------	--------------	--------------	--------------	--------------

Electrical characteristics (HF) at 20 °C

Frequency MHz	Attenuation dB/100 m		NEXT dB		PS-NEXT dB		ACR dB at 100 m		PS-ACR dB at 100 m		EL-FEXT dB at 100 m		PS-ELFEXT dB at 100 m		RL dB	
	typ.	Cat. 7 max.*	typ.	Cat. 7 max.*	typ.	Cat. 7 max.*	typ.	Cat. 7 max.*	typ.	Cat. 7 max.*	typ.	Cat. 7 max.*	typ.	Cat. 7 max.*	typ.	Cat. 7 max.*
1	1.7	2	105	80	102	77	104	78	101	75	105	80	102	77	27.1	23
10	4.5	5.7	105	80	102	77	101	74	98	71	108	74	105	71	35.2	25
100	15.4	18.5	105	72	102	69	90	54	87	51	93	54	90	51	38.9	20.1
200	22.9	26.8	105	68	102	65	83	41	80	38	85	48	82	45	36.6	18
250	26	30.2	105	66	102	63	79	36	76	33	82	46	79	43	35.3	17.3
500	35.9	44.1	100	62	97	59	64	18	61	15	70	40	67	37	29.4	17.3
600	40.4	48.9	95	61	92	58	55	12	52	9	63	38	60	35	26.6	17.3
700	44.6	–	95	–	92	–	50	–	47	–	60	–	57	–	25.8	–
800	47.7	–	93	–	90	–	45	–	42	–	57	–	54	–	25	–
900	51.6	–	90	–	87	–	38	–	35	–	53	–	50	–	23.6	–
1000	54.8	–	88	–	85	–	33	–	30	–	48	–	45	–	22.3	–
1100	56.9	–	87	–	84	–	30	–	27	–	44	–	41	–	21.4	–
1300	61.4	–	80	–	77	–	21	–	18	–	39	–	36	–	18.3	–

* EN 50288-4-1 (2014)/IEC 61156-5 (2009)

Electrical characteristics (LF) at 20 °C

Direct current resistance	max.	57.1 Ω/km
Insulation resistance	min.	5 GΩ x km
Mutual capacitance	approx.	40 pF/m
Capacitive coupling (e)	approx.	1100 pF/km
Signal tempo (c)	approx.	0.80
Propagation delay	approx.	420 ns/100 m
Skew at 100 MHz	approx.	5 ns/100 m
Charact. impedance	at 100 MHz	100 ± 5 Ω
Testing voltage U _{eff}		1000 V
Operating voltage	max.	125 V

Thermal properties

For fixed installation	–20 °C to +60 °C
For mobile operation	0 °C to +50 °C

Chemical characteristics

Free of hazardous substances acc. to RoHS 2011/65/EU

Cable printing

Inner sheath >>
LEONI MegaLine F10-130 S/F 4P H SPACE Code "xxxxx"
"CPR Class" "DoP no." "VDE mark" Made in Germany
"Batch number" "Metre marking"

Outer sheath >>
LEONI MegaLine F10-130 S/F 4P HQH SPICE Code "xxxxx"
Made in Germany "Batch number" "Metre marking"

Colour code

WH/BU, WH/OG, WH/GN, WH/BN

Certificates and approvals

Quality mark with production control:

<VDE>, GHMT PVP

Link performance: LEONI MegaLine® systems

and other commonly available connector systems

Test certificates: according to DIN 55350-18-4.2.1 or EN 10204

Compliant with LVD (2014/35/EU): 

Dimension	Outer Ø approx.	Weight approx.	Copper no.*	Sheath colour	Order no.
	mm	kg/km	kg/km		
4P	11.7	185	45	● Sky blue	LKD 7KS7 001U xxxx

Packaging: xxxx

Standard length: 0100 = 1000 m 0000 = general

* see page 17: Definition of copper no.

MegaLine® F10-130 S/F Vö

Category 7A

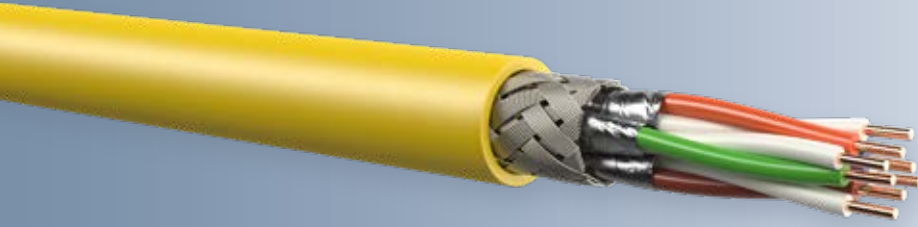

Advantages

- Better than Category 7_A
- bandwidth 1300 MHz
- excellent shielding characteristics
- reinforced outer sheath
- VDE certified
- PVP-GHMT
- RoHS and REACH conformity

TypeKS-02YSCHVö 4x2xAWG 22/1 PIMF

Construction for 4P

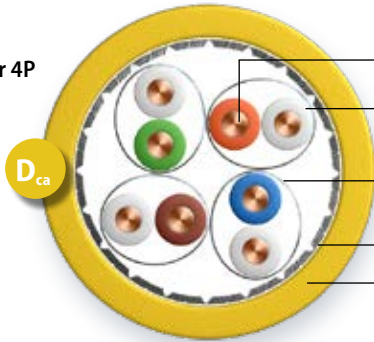

Conductor	Bare copper wire, AWG 22/1
Insulation	Cellular PE, core Ø: nominal value 1.6 mm
Twisting element	Pair
Individual shielding	Aluminium bonded polyester foil, metal on the outside (PiMF)
Twisting	4 pairs
Overall shielding	Tinned copper braid
Outer sheath	halogen-free, flame-retardant compound

Fire behaviour

Flame retardancy	acc. to IEC 60332-3-24
Halogen free	acc. to IEC 60754-1/2
Smoke density	acc. to IEC 61034-1/2
Fire load (reference value)	0.80 MJ/m

Performance

Better than Category 7 acc. to EN 50288 and IEC 61156
excellent NEXT, low attenuation, excellent shielding characteristics (pairs and overall shielding), low skew, bandwidth (typical) 1300 MHz

Applications

Installation cable for use in structured cabling acc. to ISO/IEC 11801 and EN 50173 (3rd Edition).
Ideal for all applications of Classes D to F_A, multimedia (video, data voice) > 10 GbE acc. to IEEE 802.3 an, cable sharing, VoIP, PoE/PoE+.
For use in harsh environments due to high-strength H sheath.

Mechanical characteristics

Bending radius during installation	8 x outer diameter (min.)
after installation	4 x outer diameter (min.)
Tensile strength (max.)	130 N
Crush strength	1000 N/100 mm
Impact strength (number of shocks)	10

Electromagnetic behaviour

Coupling resistance at 10 MHz (nom.)	5 mΩ/m
Shield attenuation up to 1000 MHz (nom.)	70 dB
Coupling attenuation up to 1000 MHz (nom.)	85 dB
Separating class acc. to EN 50174-2	d

Security (fire behaviour)

S	1	2	3	4	5
	IEC 60332-2-2	IEC-60332-1-2	IEC-60332-3-24	EFP Grade 1	EFP Grade 2
		E _{ca} /D _{ca}	E _{ca} /D _{ca}	C _{ca}	B2 _{ca}

Performance (cable class, bandwidth)

P	1	2	3	4	5
	> Class E > 250 MHz	> Class E _A > 500 MHz	> Class F > 600 MHz	> Class F _A > 1000 MHz	> Class F _A + > 1200 MHz

Industrial application (ethernet, TV)

I	1	2	3	4	5
	> 100 MbE	> 1 GbE	up to 10 GbE	> 10 GbE	> 10 GbE TV

Construction (conductor dimension, tensile strength)

C	1	2	3	4	5
	AWG 27	AWG 26/25	AWG 24	AWG 23	AWG 22

EMC (coupling attenuation)

E	1	2	3	4	5
	> 40 dB	> 50 dB	> 60 dB	> 70 dB	> 80 dB

Electrical characteristics (HF) at 20 °C

Frequency MHz	Attenuation dB/100 m		NEXT dB		PS-NEXT dB		ACR dB at 100 m		PS-ACR dB at 100 m		EL-FEXT dB at 100 m		PS-ELFEXT dB at 100 m		RL dB	
	typ.	Cat. 7 max.*	typ.	Cat. 7 max.*	typ.	Cat. 7 max.*	typ.	Cat. 7 max.*	typ.	Cat. 7 max.*	typ.	Cat. 7 max.*	typ.	Cat. 7 max.*	typ.	Cat. 7 max.*
1	1.7	2	105	80	102	77	104	78	101	75	105	80	102	77	27.1	23
10	4.5	5.7	105	80	102	77	101	74	98	71	108	74	105	71	35.2	25
100	15.4	18.5	105	72	102	69	90	54	87	51	93	54	90	51	38.9	20.1
200	22.9	26.8	105	68	102	65	83	41	80	38	85	48	82	45	36.6	18
250	26	30.2	105	66	102	63	79	36	76	33	82	46	79	43	35.3	17.3
500	35.9	44.1	100	62	97	59	64	18	61	15	70	40	67	37	29.4	17.3
600	40.4	48.9	95	61	92	58	55	12	52	9	63	38	60	35	26.6	17.3
700	44.6	-	95	-	92	-	50	-	47	-	60	-	57	-	25.8	-
800	47.7	-	93	-	90	-	45	-	42	-	57	-	54	-	25	-
900	51.6	-	90	-	87	-	38	-	35	-	53	-	50	-	23.6	-
1000	54.8	-	88	-	85	-	33	-	30	-	48	-	45	-	22.3	-
1100	56.9	-	87	-	84	-	30	-	27	-	44	-	41	-	21.4	-
1300	61.4	-	80	-	77	-	21	-	18	-	39	-	36	-	18.3	-

* EN 50288-4-1 (2014)/IEC 61156-5 (2009)

Electrical characteristics (LF) at 20 °C

Direct current resistance	max.	57.1 Ω/km
Insulation resistance	min.	5 GΩ x km
Mutual capacitance	approx.	40 pF/m
Capacitive coupling (e)	approx.	1100 pF/km
Signal tempo (c)	approx.	0.80
Propagation delay	approx.	420 ns/100 m
Skew at 100 MHz	approx.	5 ns/100 m
Charact. impedance	at 100 MHz	100 ± 5 Ω
Testing voltage U _{eff}		1000 V
Operating voltage	max.	125 V

Thermal properties

For fixed installation	-20 °C to +60 °C
For mobile operation	0 °C to +50 °C

Chemical characteristics

Free of hazardous substances acc. to RoHS 2011/65/EU
Oil resistance acc. to ICEA S-82-552 (60 °C)

Cable printing

LEONI MegaLine F10-130 S/F 4P HVö SPICE Code "xxxxx"
"CPR Class" "DoP no." "VDE mark" Made in Germany
"Batch number" "Metre marking"

Colour code

WH/BU, WH/OG, WH/GN, WH/BN

Certificates and approvals

Quality mark with production control:

<VDE>, GHMT PVP

Link performance: LEONI MegaLine® systems

and other commonly available connector systems

Test certificates: according to DIN 55350-18-4.2.1 or EN 10204

Compliant with LVD (2014/35/EU): 

Dimension	Outer Ø approx.	Weight approx.	Copper no.*	CPR class	DoP no.	Sheath colour	Order no.
	mm	kg/km	kg/km				
4P	8.8	84	45	D _{ca} s2 d2 a1	CDESK0000046	● Rape yellow	LKD 7KS7 0089 xxxx

Packaging: xxxx

Standard length: 0100 = 1000 m 0050 = 500 m 0000 = general

* see page 17: Definition of copper no.

MegaLine® F10-115 S/F V

Category 7A

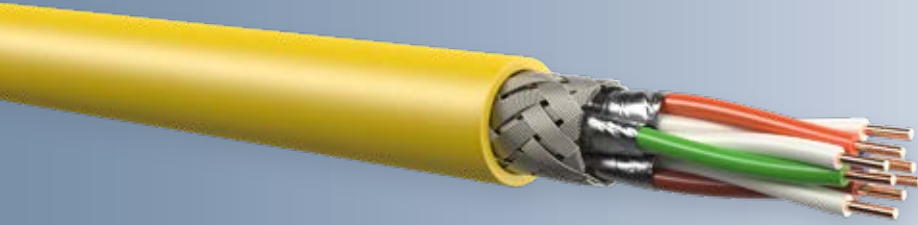

Advantages

- Better than Category 7_A
- bandwidth 1150 MHz
- excellent shielding characteristics
- reinforced outer sheath
- VDE certified
- PVP-GHMT
- RoHS and REACh conformity

Type KS-02YSCHV 4x2xAWG 23/1 PIMF

Construction for 4P

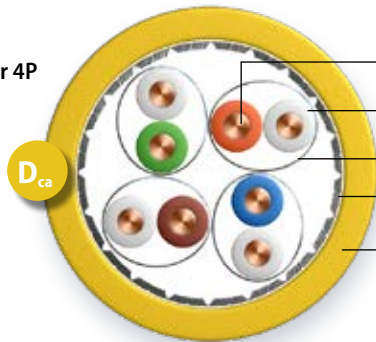

Conductor	Bare copper wire, AWG 23/1
Insulation	Cellular PE, core Ø: nominal value 1.4 mm
Twisting element	Pair
Twisting	4 pairs
Overall shielding	Tinned copper braid
Outer sheath	halogen-free, flame-retardant compound wall thickness 1.0 mm

Fire behaviour	
Flame retardancy	acc. to IEC 60332-3-24
Halogen free	acc. to IEC 60754-1/2
Smoke density	acc. to IEC 61034-1/2
Fire load (reference value)	0.7 MJ/m

Performance	
Better than Category 7 acc. to EN 50288 and IEC 61156 excellent NEXT, excellent shielding characteristics (pairs and overall shielding), low skew, bandwidth (typical) 1150 MHz	

Applications	
Installation cable for use in structured cabling acc. to ISO/IEC 11801 and EN 50173 (2nd Edition). Ideal for all applications of Classes D to F _A , multimedia (video, data voice) > 10 GbE acc. to IEEE 802.3 an, cable sharing, VoIP, PoE/PoE+. For use in harsh environments due to high-strength H sheath.	

Mechanical characteristics	
Bending radius during installation	8 x outer diameter (min.)
after installation	4 x outer diameter (min.)
Tensile strength (max.)	110 N
Crush strength	1000 N/100 mm
Impact strength (number of shocks)	10

Electromagnetic behaviour	
Coupling resistance at 10 MHz (nom.)	5 mΩ/m
Shield attenuation up to 1000 MHz (nom.)	70 dB
Coupling attenuation up to 1000 MHz (nom.)	85 dB
Separating class acc. to EN 50174-2	d

Security (fire behaviour)

S	1 IEC 60332-2-2	2 IEC-60332-1-2 E _{ca} /D _{ca}	3 IEC-60332-3-24 E _{ca} /D _{ca}	4 EFP Grade 1 C _{ca}	5 EFP Grade 2 B2 _{ca}
----------	--------------------	--	---	--	---

Performance (cable class, bandwidth)

P	1 > Class E > 250 MHz	2 > Class E _A > 500 MHz	3 > Class F > 600 MHz	4 > Class F _A > 1000 MHz	5 > Class F _A + > 1200 MHz
----------	-----------------------------	--	-----------------------------	---	---

Industrial application (ethernet, TV)

I	1 > 100 MbE	2 > 1 GbE	3 up to 10 GbE	4 > 10 GbE	5 > 10 GbE TV
----------	----------------	--------------	-------------------	---------------	---------------------

Construction (conductor dimension, tensile strength)

C	1 AWG 27	2 AWG 26/25	3 AWG 24	4 AWG 23	5 AWG 22
----------	-------------	----------------	-------------	-------------	-------------

EMC (coupling attenuation)

E	1 > 40 dB	2 > 50 dB	3 > 60 dB	4 > 70 dB	5 > 80 dB
----------	--------------	--------------	--------------	--------------	--------------

Electrical characteristics (HF) at 20 °C

Frequency MHz	Attenuation dB/100 m		NEXT dB		PS-NEXT dB		ACR dB at 100 m		PS-ACR dB at 100 m		EL-FEXT dB at 100 m		PS-ELFEXT dB at 100 m		RL dB	
	typ.	Cat. 7 max.*	typ.	Cat. 7 max.*	typ.	Cat. 7 max.*	typ.	Cat. 7 max.*	typ.	Cat. 7 max.*	typ.	Cat. 7 max.*	typ.	Cat. 7 max.*	typ.	Cat. 7 max.*
1	1.9	2	105	80	102	77	104	78	101	75	98	80	95	77	26.6	23
10	4.8	5.7	105	80	102	77	101	74	98	71	103	74	100	71	35.3	25
100	16.3	18.5	105	72	102	69	89	54	86	51	89	54	86	51	39.6	20.1
200	24.3	26.8	105	68	102	65	81	41	78	38	82	48	79	45	36	18
250	27.5	30.2	105	66	102	63	78	36	75	33	79	46	76	43	34	17.3
500	37.9	44.1	100	62	97	59	62	18	59	15	67	40	64	37	29	17.3
600	42.4	48.9	95	61	92	58	53	12	50	9	60	38	57	35	25.4	17.3
700	47.2	–	95	–	92	–	48	–	45	–	57	–	54	–	24.6	–
800	50.3	–	93	–	90	–	43	–	40	–	53	–	50	–	23.5	–
900	54.6	–	90	–	87	–	35	–	32	–	49	–	46	–	22.6	–
1000	58	–	88	–	85	–	30	–	27	–	44	–	41	–	21.5	–
1150	61.9	–	86	–	83	–	25	–	22	–	39	–	36	–	20.6	–

* EN 50288-4-1 (2014)/IEC 61156-5 (2009)

Electrical characteristics (LF) at 20 °C

Direct current resistance	max.	75 Ω/km
Insulation resistance	min.	5 GΩ x km
Mutual capacitance	approx.	42 pF/m
Capacitive coupling (e)	approx.	1100 pF/km
Signal tempo (c)	approx.	0.80
Propagation delay	approx.	420 ns/100 m
Skew at 100 MHz	approx.	5 ns/100 m
Charact. impedance	at 100 MHz	100 ± 5 Ω
Testing voltage U _{eff}		1000 V
Operating voltage	max.	125 V

Thermal properties

For fixed installation	–20 °C to +60 °C
For mobile operation	0 °C to +50 °C

Chemical characteristics

Free of hazardous substances acc. to RoHS 2011/65/EU

Cable printing

LEONI MegaLine F10-115 S/F 4P HV SPICE Code "xxxxx"
 "CPR Class" "DoP no." "VDE mark" Made in Germany
 "Batch number" "Metre marking"

Colour code

WH/BU, WH/OG, WH/GN, WH/BN

Certificates and approvals

Quality mark with production control:

<VDE>, GHMT PVP

Link performance: LEONI MegaLine® systems

and other commonly available connector systems

Test certificates: according to DIN 55350-18-4.2.1 or EN 10204

Compliant with LVD (2014/35/EU): **CE**

Dimension	Outer Ø approx.	Weight approx.	Copper no.*	CPR class	DoP no.	Sheath colour	Order no.
	mm	kg/km	kg/km				
4P	8.1	77	37	D _{ca} s2 d2 a1	CDESK0000045	● Rape yellow	LKD 7K57 0049 xxxx

Packaging: xxxx

Standard length: 0100 = 1000 m 0050 = 500 m 0000 = general

* see page 17: Definition of copper no.

MegaLine® F6-90 S/F 2Y

Category 7

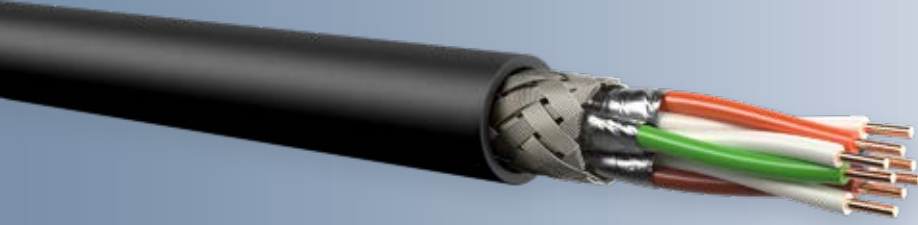

Type KS-02YSC2Y 4x2xAWG 23/1 PIMF

Construction for 4P

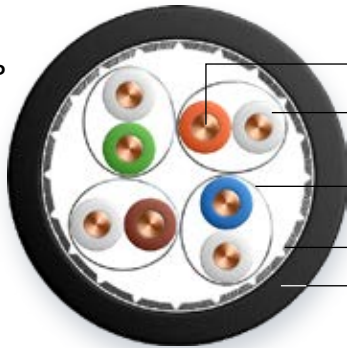

Conductor	Bare copper wire, AWG 23/1
Insulation	Cellular PE, core Ø: nominal value 1.4 mm
Twisting element	Pair
Individual shielding	Aluminium bonded polyester foil, metal on the outside (PiMF)
Twisting	4 pairs
Overall shielding	Tinned copper braid
Outer sheath	PE

Advantages

- Better than Category 7
- bandwidth 1000 MHz
- excellent shielding characteristics
- for installation outdoors and in the ground
- PVP-GHMT
- RoHS and REACH conformity

Fire behaviour

Halogen free	acc. to IEC 60754-1/2
Smoke density	acc. to IEC 61034-1/2

Performance

Better than Category 7 acc. to EN 50288 and IEC 61156
excellent NEXT, excellent shielding characteristics (pairs and overall shielding), low skew, bandwidth (typical) 900 MHz

Applications

Installation cable for use in structured cabling acc. to ISO/IEC 11801 and EN 50173 (3rd Edition).

Ideal for all applications of Classes D to F, multimedia(video, data voice) > 10 GbE acc. to IEEE 802.3 an, cable sharing, VoIP, PoE/PoE+.

For use outdoors and underground installation.

Mechanical characteristics

Bending radius during installation	8 x outer diameter (min.)
after installation	4 x outer diameter (min.)
Tensile strength (max.)	110 N
Crush strength	2000 N/100 mm
Impact strength (number of shocks)	20

Electromagnetic behaviour

Coupling resistance at 10 MHz (nom.)	5 mΩ/m
Shield attenuation up to 1000 MHz (nom.)	70 dB
Coupling attenuation up to 1000 MHz (nom.)	85 dB
Separating class acc. to EN 50174-2	d

Security (fire behaviour)

S	1 IEC 60332-2-2	2 IEC-60332-1-2	3 IEC-60332-3-24	4 EFP Grade 1	5 EFP Grade 2
----------	--------------------	--------------------	---------------------	---------------------	---------------------

Performance (cable class, bandwidth)

P	1 > Class E > 250 MHz	2 > Class E _A > 500 MHz	3 > Class F > 600 MHz	4 > Class F _A > 1000 MHz	5 > Class F _{A+} > 1200 MHz
----------	-----------------------------	--	-----------------------------	---	--

Industrial application (ethernet, TV)

I	1 > 100 MbE	2 > 1 GbE	3 up to 10 GbE	4 > 10 GbE	5 > 10 GbE TV
----------	----------------	--------------	-------------------	---------------	---------------------

Construction (conductor dimension, tensile strength)

C	1 AWG 27	2 AWG 26/25	3 AWG 24	4 AWG 23	5 AWG 22
----------	-------------	----------------	-------------	-------------	-------------

EMC (coupling attenuation)

E	1 > 40 dB	2 > 50 dB	3 > 60 dB	4 > 70 dB	5 > 80 dB
----------	--------------	--------------	--------------	--------------	--------------

Electrical characteristics (HF) at 20 °C

Frequency MHz	Attenuation dB/100 m		NEXT dB		PS-NEXT dB		ACR dB at 100 m		PS-ACR dB at 100 m		EL-FEXT dB at 100 m		PS-ELFEXT dB at 100 m		RL dB	
	typ.	Cat. 7 max.*	typ.	Cat. 7 min.*	typ.	Cat. 7 min.*	typ.	Cat. 7 min.*	typ.	Cat. 7 min.*	typ.	Cat. 7 min.*	typ.	Cat. 7 min.*	typ.	Cat. 7 min.*
1	1.9	2	102	80	99	77	101	78	98	75	109	80	106	77	25.4	23
10	4.8	5.7	102	80	99	77	98	74	95	71	108	74	105	71	31.1	25
100	16.4	18.5	102	72	99	69	86	54	83	51	93	54	90	51	33.2	20.1
200	24.5	26.8	102	68	99	65	78	41	75	38	85	48	82	45	33.2	18
250	27.8	30.2	102	66	99	63	75	36	72	33	82	46	79	43	33.4	17.3
450	36.1	44.6	97	63	94	60	61	21	58	18	72	41	69	38	31.4	17.3
500	38.2	44.1	97	62	94	59	59	18	56	15	68	40	65	37	30.5	17.3
600	42.9	48.9	92	61	89	58	49	12	46	9	62	38	59	35	27.6	17.3
700	47.7	–	92	–	89	–	44	–	41	–	59	–	56	–	26.2	–
800	50.8	–	90	–	87	–	39	–	36	–	56	–	53	–	23.9	–
900	55.1	–	85	–	82	–	30	–	27	–	52	–	49	–	21.7	–

* EN 50288-4-1 (2014)/IEC 61156-5 (2009)

Electrical characteristics (LF) at 20 °C

Direct current resistance	max.	75 Ω/km
Insulation resistance	min.	5 GΩ x km
Mutual capacitance	approx.	42 pF/m
Capacitive coupling (e)	approx.	1100 pF/km
Signal tempo (c)	approx.	0.80
Propagation delay	approx.	420 ns/100 m
Skew at 100 MHz	approx.	5 ns/100 m
Charact. impedance	at 100 MHz	100 ± 5 Ω
Testing voltage U _{eff}		1000 V
Operating voltage	max.	125 V

Thermal properties

For fixed installation	-25 °C to +70 °C
For mobile operation	-10 °C to +50 °C

Chemical characteristics

Free of hazardous substances acc. to RoHS 2011/65/EU
 UV resistance according to UL 1581 and ISO 4892,
 Free of lacquer-wetting substances (e.g. silicon oil)

Cable printing

LEONI MegaLine F6-90 S/F 4P 2Y SPICE Code "xxxxx"
 Made in Germany "Batch number" "Metre marking"

Colour code

WH/BU, WH/OG, WH/GN, WH/BN

Certificates and approvals

Quality mark with production control: GHMT PVP
 Link performance: LEONI MegaLine® systems
 and other commonly available connector systems
 Test certificates: according to DIN 55350-18-4.2.1 or EN 10204
 Compliant with LVD (2014/35/EU): 

Dimension	Outer Ø approx.	Weight approx.	Copper no.*	Sheath colour	Order no.
	mm	kg/km	kg/km		
4P	9.0	70	35	● Jet black	LKD 7KS7 0169 xxxxx

Packaging: xxxxx

Standard length: 0100 = 1000 m 0000 = general

* see page 17: Definition of copper no.

MegaLine® D1-20 SF/U 2Y

Category 5



Type KS-02YS(ST+C)H2Y 4x2xAWG 24/1

Advantages

- Better than Category 5
- bandwidth 200 MHz
- good shielding characteristics
- for installation outdoors and in the ground
- RoHS and REACh conformity

Construction for 4P

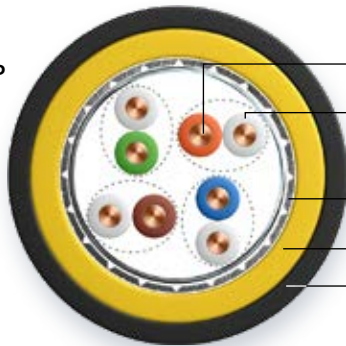

Conductor	Bare copper wire, AWG 24/1
Insulation	Cellular PE, core Ø: nominal value 1.1 mm
Twisting element	Pair
Twisting	4 pairs
Overall shielding	Aluminium bonded polyester foil and Tinned copper braid
Inner sheath	halogen-free, flame-retardant compound
Outer sheath	PE

Fire behaviour

Halogen free	acc. to IEC 60754-1/2
Smoke density	acc. to IEC 61034-1/2
Fire load (reference value)	1.88 MJ/m

Performance

Better than Category 5 acc. to EN 50288 and IEC 61156
excellent shielding characteristics, bandwidth (typical) 200 MHz

Applications

Installation cable for use in structured cabling acc. to ISO/IEC 11801 and EN 50173 (3rd Edition). Ideal for all applications of classes D up to 1 GbE acc. to IEEE 802.3 ab, VoIP, PoE/PoE+.
For use outdoors and underground installation.

Mechanical characteristics

Bending radius during installation	8 x outer diameter (min.)
after installation	4 x outer diameter (min.)
Tensile strength (max.)	85 N
Crush strength	3000 N/100 mm
Impact strength (number of shocks)	50

Electromagnetic behaviour

Coupling resistance at 10 MHz (nom.)	10 mΩ/m
Shield attenuation up to 1000 MHz (nom.)	55 dB
Coupling attenuation up to 1000 MHz (nom.)	70 dB
Separating class acc. to EN 50174-2	c

Security (fire behaviour)

S	1 IEC 60332-2-2	2 IEC-60332-1-2	3 IEC-60332-3-24	4 EFP Grade 1	5 EFP Grade 2
----------	--------------------	--------------------	---------------------	------------------	------------------

Performance (cable class, bandwidth)

P	1 > Class E >250 MHz	2 > Class E _s >500 MHz	3 > Class F >600 MHz	4 > Class F _s >1000 MHz	5 > Class F _s + >1200 MHz
----------	----------------------------	---	----------------------------	--	--

Industrial application (ethernet, TV)

I	1 >100 MbE	2 >1 GbE	3 up to 10 GbE	4 >10 GbE	5 >10 GbE TV
----------	---------------	-------------	-------------------	--------------	-----------------

Construction (conductor dimension, tensile strength)

C	1 AWG 27	2 AWG 26/25	3 AWG 24	4 AWG 23	5 AWG 22
----------	-------------	----------------	-------------	-------------	-------------

EMC (coupling attenuation)

E	1 >40 dB	2 >50 dB	3 >60 dB	4 >70 dB	5 >80 dB
----------	-------------	-------------	-------------	-------------	-------------

Electrical characteristics (HF) at 20 °C

Frequency MHz	Attenuation dB/100 m		NEXT dB		PS-NEXT dB		ACR dB at 100 m		PS-ACR dB at 100 m		EL-FEXT dB at 100 m		PS-ELFEXT dB at 100 m		RL dB	
	typ.	Cat. 5 max.*	typ.	Cat. 5 min.*	typ.	Cat. 5 min.*	typ.	Cat. 5 min.*	typ.	Cat. 5 min.*	typ.	Cat. 5 min.*	typ.	Cat. 5 min.*	typ.	Cat. 5 min.*
1	2	2.1	75	65	72	62	73	63	70	60	89	64	86	61	24.8	-
4	3.1	4	69	56	66	53	66	52	63	49	84	52	81	49	28.6	23
10	5.1	6.3	62	50	59	47	57	44	54	41	76	44	73	41	33.3	25
16	7	8	58	47	55	44	51	39	48	36	70	40	67	37	34.3	25
31.25	9.7	11.4	53	43	50	40	44	31	41	28	63	34	60	31	33.9	23.6
62.5	13.2	16.5	49	38	46	35	36	22	33	19	58	28	55	25	31.3	21.5
100	17.6	21.3	45	35	42	32	28	14	25	11	52	24	49	21	27.7	20.1
155	22.3	-	42	-	39	-	20	-	17	-	49	-	46	-	24.7	-
200	26.5	-	40	-	37	-	14	-	11	-	45	-	42	-	22.4	-

* EN 50288-4-1 (2014)/IEC 61156-5 (2009)

Electrical characteristics (LF) at 20 °C

Direct current resistance	max.	95 Ω/km
Insulation resistance	min.	5 GΩ x km
Mutual capacitance	approx.	45 pF/m
Capacitive coupling (e)	approx.	1100 pF/km
Signal tempo (c)	approx.	0.75
Propagation delay	approx.	440 ns/100 m
Skew at 100 MHz	approx.	15 ns/100 m
Charact. impedance	at 100 MHz	100 ± 5 Ω
Testing voltage U _{eff}		1000 V
Operating voltage	max.	125 V

Thermal properties

For fixed installation	-25 °C to +70 °C
For mobile operation	-10 °C to +50 °C

Chemical characteristics

Free of hazardous substances acc. to RoHS 2011/65/EU
UV resistance according to UL 1581 and ISO 4892

Cable printing

Inner sheath >>

LEONI MegaLine D1-20 SF/U 4P H SPACE Code "xxxxx"
"CPR Class" "DoP no." Made in Germany "Batch number" "Metre marking"

Outer sheath >>

LEONI MegaLine D1-20 SF/U 4P H2Y SPICE Code "xxxxx"
Made in Germany "Batch number" "Metre marking"

Colour code

WH-BU/BU, WH-OG/OG, WH-GN/GN, WH-BN/BN

Certificates and approvals

Link performance: LEONI MegaLine® systems
and other commonly available connector systems
Test certificates: according to DIN 55350-18-4.2.1 or EN 10204
Compliant with LVD (2014/35/EU): 

Dimension	Outer Ø approx.	Weight approx.	Copper no.*	Sheath colour	Order no.
	mm	kg/km	kg/km		
4P	8.8	70	26	● Jet black	LKD 7KS5 001U xxxx

Packaging: xxxx

Standard length: 0100 = 1000 m 0000 = general

* see page 17: Definition of copper no.

MegaLine® D1-20 SF/U HHQH

Category 5

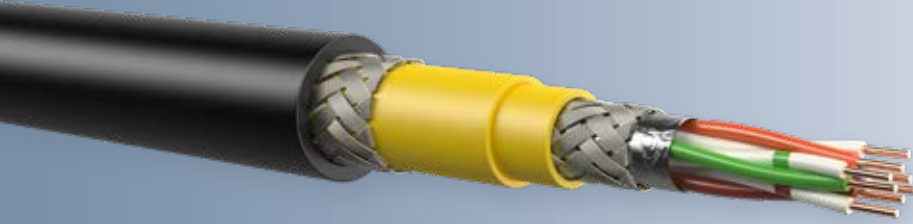

Type KS-02YS(ST+C)HHQH 4x2xAWG 24/1

Advantages

- Better than Category 5
- bandwidth 200 MHz
- good shielding characteristics
- for installation in outdoor areas and in harsh environments
- RoHS and REACh conformity

Construction

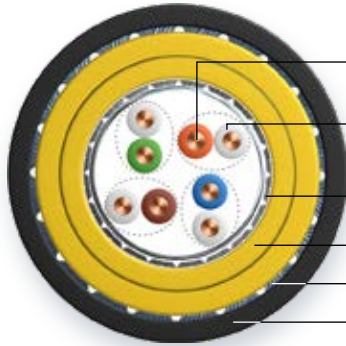

Conductor	Bare copper wire, AWG 24/1
Insulation	Cellular PE, core Ø: nominal value 1.1 mm
Twisting element	Pair
Twisting	4 pairs
Overall shielding	Aluminium bonded polyester foil and Tinned copper braid
Inner sheath	2 layers of halogen-free, flame-retardant compound
Armour	Galvanised steel wire braiding
Outer sheath	halogen-free, flame-retardant compound

Fire behaviour

Flame retardancy	acc. to IEC 60332-1-2
Halogen free	acc. to IEC 60754-1/2
Smoke density	acc. to IEC 61034-1/2
Fire load (reference value)	2.1 MJ/m

Performance

Better than Category 5 acc. to EN 50288 and IEC 61156
excellent shielding characteristics, bandwidth (typical) 200 MHz

Applications

Installation cable for use in structured cabling acc. to ISO/IEC 11801 and EN 50173 (3rd Edition).

Ideal for all applications of Classes D up to 1 GbE acc. to IEEE 802.3 ab, cable sharing, VoIP, PoE/PoE+. For universal indoor and outdoor use.

Mechanical characteristics

Bending radius during installation	8 x outer diameter (min.)
after installation	4 x outer diameter (min.)
Tensile strength (max.)	1200 N
Crush strength	3000 N/100 mm
Impact strength (number of shocks)	50

Electromagnetic behaviour

Coupling resistance at 10 MHz (nom.)	10 mΩ/m
Shield attenuation up to 1000 MHz (nom.)	55 dB
Coupling attenuation up to 1000 MHz (nom.)	70 dB
Separating class acc. to EN 50174-2	c

Security (fire behaviour)

S	1 IEC 60332-2-2	2 IEC-60332-1-2	3 IEC-60332-3-24	4 EFP Grade 1	5 EFP Grade 2
----------	--------------------	--------------------	---------------------	---------------------	---------------------

Performance (cable class, bandwidth)

P	1 > Class E > 250 MHz	2 > Class E _A > 500 MHz	3 > Class F > 600 MHz	4 > Class F _A > 1000 MHz	5 > Class 7 _A + > 1200 MHz
----------	-----------------------------	--	-----------------------------	---	---

Industrial application (ethernet, TV)

I	1 > 100 MbE	2 > 1 GbE	3 up to 10 GbE	4 > 10 GbE	5 > 10 GbE TV
----------	----------------	--------------	-------------------	---------------	---------------------

Construction (conductor dimension, tensile strength)

C	1 AWG 27	2 AWG 26/25	3 AWG 24	4 AWG 23	5 AWG 22
----------	-------------	----------------	-------------	-------------	-------------

EMC (coupling attenuation)

E	1 > 40 dB	2 > 50 dB	3 > 60 dB	4 > 70 dB	5 > 80 dB
----------	--------------	--------------	--------------	--------------	--------------

Electrical characteristics (HF) at 20 °C

Frequency MHz	Attenuation dB/100 m		NEXT dB		PS-NEXT dB		ACR dB at 100 m		PS-ACR dB at 100 m		EL-FEXT dB at 100 m		PS-ELFEXT dB at 100 m		RL dB	
	typ.	Cat. 5 max.*	typ.	Cat. 5 min.*	typ.	Cat. 5 min.*	typ.	Cat. 5 min.*	typ.	Cat. 5 min.*	typ.	Cat. 5 min.*	typ.	Cat. 5 min.*	typ.	Cat. 5 min.*
1	2	2.1	75	65	72	62	73	63	70	60	89	64	86	61	24.8	–
4	3.1	4	69	56	66	53	66	52	63	49	84	52	81	49	28.6	23
10	5.1	6.3	62	50	59	47	57	44	54	41	76	44	73	41	33.3	25
16	7	8	58	47	55	44	51	39	48	36	70	40	67	37	34.3	25
31.25	9.7	11.4	53	43	50	40	44	31	41	28	63	34	60	31	33.9	23.6
62.5	13.2	16.5	49	38	46	35	36	22	33	19	58	28	55	25	31.3	21.5
100	17.6	21.3	45	35	42	32	28	14	25	11	52	24	49	21	27.7	20.1
155	22.3	–	42	–	39	–	20	–	17	–	49	–	46	–	24.7	–
200	26.5	–	40	–	37	–	14	–	11	–	45	–	42	–	22.4	–

* EN 50288-2-1(2014)/IEC 61156-5 (2009)

Electrical characteristics (LF) at 20 °C

Direct current resistance	max.	95 Ω/km
Insulation resistance	min.	5 GΩ x km
Mutual capacitance	approx.	45 pF/m
Capacitive coupling (e)	approx.	1100 pF/km
Signal tempo (c)	approx.	0.75
Propagation delay	approx.	440 ns/100 m
Skew at 100 MHz	approx.	15 ns/100 m
Charact. impedance	at 100 MHz	100 ± 5 Ω
Testing voltage U _{eff}		1000 V
Operating voltage	max.	125 V

Thermal properties

For fixed installation	–20 °C to +60 °C
For mobile operation	0 °C to +50 °C

Chemical characteristics

Free of hazardous substances acc. to RoHS 2011/65/EU

Cable printing

Inner sheath >>

LEONI MegaLine D1–20 SF/U 4P H SPACE Code "xxxxx"
"CPR Class" "DoP no." Made in Germany "Batch number" "Metre marking"

Outer sheath >>

LEONI MegaLine D1–20 SF/U 4P HHQH SPICE Code "xxxxx"
Made in Germany "Batch number" "Metre marking"

Colour code

WH-BU/BU, WH-OG/OG, WH-GN/GN, WH-BN/BN

Certificates and approvals

Link performance: LEONI MegaLine® systems
and other commonly available connector systems
Test certificates: according to DIN 55350-18-4.2.1 or EN 10204
Compliant with LVD (2014/35/EU): 

Dimension	Outer Ø approx.	Weight approx.	Copper no.*	Sheath colour	Order no.
	mm	kg/km	kg/km		
4P	11.9	194	26	● Jet black	LKD 7KS5 002U xxxx

Packaging: xxxx

Standard length: 0100 = 1000 m 0000 = general

* see page 17: Definition of copper no.

MegaLine® F10-120 S/F 11Y flex

Category 7_A

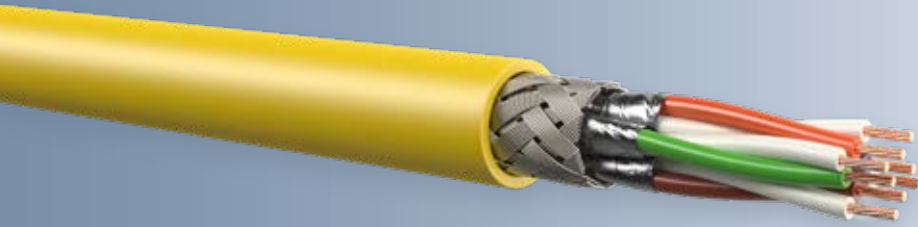

Type KS-02YSC11Y 4x2xAWG 26/7 PIMF

Advantages

- Better than Category 7
- bandwidth 1200 MHz
- excellent shielding characteristics
- for installation in outdoor areas and in harsh environments
- RoHS and REACh conformity

Construction for 4P

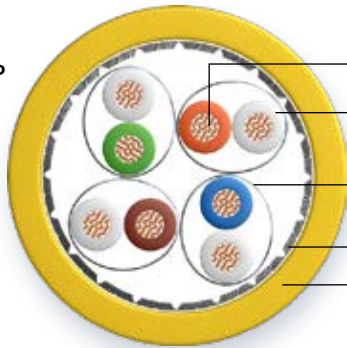

Conductor	bare copper wire, AWG 26/7
Insulation	Cellular PE, core Ø: Max. 1.05 mm
Twisting element	Pair
Individual shielding	Aluminium bonded polyester foil, metal on the outside (PiMF)
Twisting	4 pairs
Overall shielding	Tinned copper braid
Outer sheath	PUR

Fire behaviour

Flame retardancy	acc. to IEC 60332-2-2
Halogen-free	acc. to 60754-1/2
Smoke density	acc. to IEC 61034-1/2
Fire load (reference value)	0.7 MJ/m

Performance

Better than Category 7 acc. to EN 50288 and IEC 61156
excellent NEXT, low attenuation, excellent shielding characteristics (pairs and overall shielding), low skew, bandwidth (typical) 1200 MHz

Applications

Connection cable and patch cord for use in structured cabling acc. to ISO/IEC 11801 and EN 50173 (3rd Edition). Ideal for all applications of Classes D to F_A, multimedia (TV, video, data voice) > 10 GbE acc. to IEEE 802.3 an, cable sharing, VoIP, PoE/PoE+.
For use in harsh environments due to very rugged PUR sheath.

Mechanical characteristics

Bending radius	in operation	5 x outer diameter (min.)
Tensile strength (max.)		60 N

Electromagnetic behaviour

Coupling resistance at 10 MHz (nom.)	5 mΩ/m
Shield attenuation up to 1000 MHz (nom.)	60 dB
Coupling attenuation up to 1000 MHz (nom.)	85 dB
Separating class acc. to EN 50174-2	d

Security (fire behaviour)

S	1	2	3	4	5
	IEC 60332-2-2	IEC-60332-1-2	IEC-60332-3-24	EFP Grade 1	EFP Grade 2

Performance (cable class, bandwidth)

P	1	2	3	4	5
	> Class E	> Class E _A	> Class F	> Class F _A	> Class F _A +
	> 250 MHz	> 500 MHz	> 600 MHz	> 1000 MHz	> 1200 MHz

Industrial application (ethernet, TV)

I	1	2	3	4	5
	> 100 MbE	> 1 GbE	up to 10 GbE	> 10 GbE	> 10 GbE TV

Construction (conductor dimension, tensile strength)

C	1	2	3	4	5
	AWG 27	AWG 26/25	AWG 24	AWG 23	AWG 22

EMC (coupling attenuation)

E	1	2	3	4	5
	> 40 dB	> 50 dB	> 60 dB	> 70 dB	> 80 dB

Electrical characteristics (HF) at 20 °C

Frequency MHz	Attenuation dB/10m		NEXT dB		PS-NEXT dB		ACR dB at 10m		PS-ACR dB at 10m		EL-FEXT dB at 10m		PS-ELFEXT dB at 10m		RL dB	
	typ.	Cat. 7 _A max.*	typ.	Cat. 7 _A min.*	typ.	Cat. 7 _A min.*	typ.	Cat. 7 _A min.*	typ.	Cat. 7 _A min.*	typ.	Cat. 7 _A min.*	typ.	Cat. 7 _A min.*	typ.	Cat. 7 _A min.*
1	0.25	0.29	100	80	97	77	100	80	97	77	100	80	97	80	24	23
10	0.76	0.85	99	80	96	77	99	79	96	77	95	74	92	71	33.9	25
100	2.49	2.78	95	72	92	69	93	70	90	69	69	54	66	51	38.3	20.1
200	3.69	4.01	92	68	89	65	88	64	85	65	65	48	62	45	35.3	18
250	4.18	4.53	90	66	87	63	86	62	83	63	62	46	59	43	32.9	17.3
500	5.6	6.62	83	62	80	59	78	55	75	59	54	40	51	37	29.7	17.3
600	6.74	7.33	81	61	78	58	74	53	71	58	50	38	47	35	30.6	17.3
700	7.32	-	80	-	77	-	72	-	69	-	50	-	47	-	31	-
800	7.89	-	77	-	74	-	69	-	66	-	50	-	47	-	26.7	-
900	8.5	-	75	-	72	-	67	-	64	-	34	-	31	-	28.6	-
1000	9.11	-	74	-	71	-	65	-	62	-	32	-	29	-	27.5	-
1100	9.5	-	72	-	69	-	63	-	60	-	28	-	25	-	26.9	-
1200	9.9	-	70	-	67	-	61	-	58	-	24	-	21	-	26.3	-

* EN 50288-4-2(2014)/IEC 61156-6 (2010)

Electrical characteristics (LF) at 20 °C

Direct current resistance	max.	145 Ω/km
Insulation resistance	min.	5 GΩ x km
Mutual capacitance	approx.	44 pF/m
Signal tempo (c)	approx.	0.78
Propagation delay	approx.	440 ns/100 m
Skew at 100 MHz	approx.	2.5 ns/100 m
Charact. impedance	at 100 MHz	100 ± 5 Ω
Testing voltage U _{eff}		1000 V
Operating voltage	max.	125 V

Thermal properties

For fixed installation	-40 °C to +70 °C
For mobile operation	-10 °C to +50 °C

Chemical characteristics

Free of hazardous substances acc. to RoHS 2011/65/EU
Oil resistance acc. to EN 60811-2-1
Microbe resistance acc. to DIN VDE 0282
Chemical resistance
Hydrolysis resistance acc. to DIN 53504
Free of lacquer-wetting substances (e.g. silicon oil)

Cable printing

LEONI MegaLine F10-120 S/F flex 4P 11Y SPICE Code "xxxxx"
Made in Germany "Batch number" "Metre marking"

Colour code

WH/BU, WH/OG, WH/GN, WH/BN

Certificates and approvals

Link performance: LEONI MegaLine® systems
and other commonly available connector systems
Test certificates: according to DIN 55350-18-4.2.1 or EN 10204
Compliant with LVD (2014/35/EU): 

Dimension	Outer Ø approx.	Weight approx.	Copper no.*	Sheath colour	Order no.
	mm	kg/km	kg/km		
4P	6.4	45	23.5	● Rape yellow	LKD 7K57 0090 xxxx

Packaging: xxxx

Standard length: 0100 = 1000 m 0000 = general

* see page 17: Definition of copper no.

MegaLine® F6-70 S/F 11Y flex

Category 7

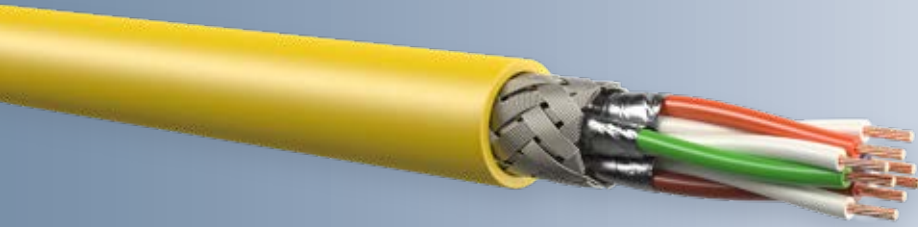

Type KS-02YSC11Y 4x2xAWG 24/7 PIMF

Advantages

- Better than Category 7
- bandwidth 700 MHz
- excellent shielding characteristics
- for installation in outdoor areas and in harsh environments
- RoHS and REACH conformity

Construction for 4P

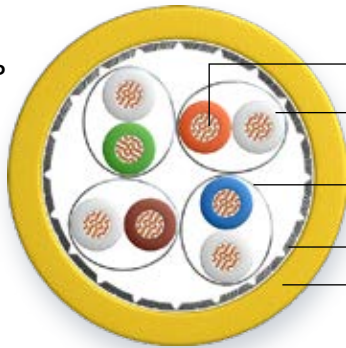

Conductor	bare copper wire, AWG 24/7
Insulation	Cellular PE, core Ø: nominal value 1.55 mm
Twisting element	Pair
Individual shielding	Aluminium bonded polyester foil, metal on the outside (PIMF)
Twisting	4 pairs
Overall shielding	Tinned copper braid
Outer sheath	PUR, flame-retardant

Fire behaviour

Flame retardancy	acc. to IEC 60332-1-2
Halogen free	acc. to IEC 60754-1/2
Smoke density	acc. to IEC 61034-1/2
Fire load (reference value)	0.99 MJ/m

Performance

Better than Category 7 acc. to EN 50288 and IEC 61156
excellent NEXT, low attenuation, excellent shielding characteristics (pairs and overall shielding), low skew, bandwidth (typical) 700 MHz

Applications

Connection cable and patch cord for use in structured cabling acc. to ISO/IEC 11801 and EN 50173 (3rd Edition).

Ideal for all applications of Classes D to F, multimedia (video, data, voice)
> 10 GbE acc. to IEEE 802.3 an, cable sharing, VoIP, PoE/PoE+.
For use in harsh environments due to very rugged PUR sheath.

Mechanical characteristics

Bending radius in operation	5 x outer diameter (min.)
Tensile strength (max.)	100 N
Crush strength	1000 N/100 mm
Impact strength (number of shocks)	10

Electromagnetic behaviour

Coupling resistance at 10 MHz (nom.)	5 mΩ/m
Shield attenuation up to 1000 MHz (nom.)	60 dB
Coupling attenuation up to 1000 MHz (nom.)	90 dB
Separating class acc. to EN 50174-2	d

Security (fire behaviour)

S	1	2	3	4	5
	IEC 60332-2-2	IEC-60332-1-2	IEC-60332-3-24	EFP Grade 1	EFP Grade 2

Performance (cable class, bandwidth)

P	1	2	3	4	5
	> Class E	> Class E _A	> Class F	> Class F _A	> Class F _{A+}
	> 250 MHz	> 500 MHz	> 600 MHz	> 1000 MHz	> 1200 MHz

Industrial application (ethernet, TV)

I	1	2	3	4	5
	> 100 MbE	> 1 GbE	up to 10 GbE	> 10 GbE	> 10 GbE TV

Construction (conductor dimension, tensile strength)

C	1	2	3	4	5
	AWG 27	AWG 26/25	AWG 24	AWG 23	AWG 22

EMC (coupling attenuation)

E	1	2	3	4	5
	> 40 dB	> 50 dB	> 60 dB	> 70 dB	> 80 dB

Electrical characteristics (HF) at 20 °C

Frequency MHz	Attenuation dB/10m		NEXT dB		PS-NEXT dB		ACR dB at 10m		PS-ACR dB at 10m		EL-FEXT dB at 10m		PS-ELFEXT dB at 10m		RL dB	
	typ.	Cat. 7 max.*	typ.	Cat. 7 min.*	typ.	Cat. 7 min.*	typ.	Cat. 7 min.*	typ.	Cat. 7 min.*	typ.	Cat. 7 min.*	typ.	Cat. 7 min.*	typ.	Cat. 7 min.*
1	0.23	0.29	90	80	87	77	90	80	87	77	90	80	87	77	23.3	-
4	0.4	0.55	90	80	87	77	90	79	87	77	90	80	87	77	25	23
10	0.63	0.85	90	80	87	77	89	79	86	77	90	74	87	71	30	25
16	0.79	1.08	90	80	87	77	89	79	86	77	90	70	87	67	30	25
20	0.91	1.21	90	80	87	77	89	79	86	77	85	68	82	65	30	25
100	2.07	2.78	81	72.4	78	69	79	70	76	69	64	54	61	51	24	20.1
200	3.07	4.01	76	67.9	73	65	73	64	70	65	57	48	54	45	24	18
250	3.43	4.53	74	66.5	71	63	71	62	68	63	53	46	50	43	24	17.3
500	4.77	6.62	70	61.9	67	59	65	55	62	59	45	40	42	37	21	17.3
600	5.23	7.33	68	60.8	65	58	63	53	60	58	42	38	39	35	21	17.3
700	5.65	-	65	-	62	-	59	-	56	-	39	-	36	-	19	-

* EN 50288-4-2(2014)/IEC 61156-6 (2010)

Electrical characteristics (LF) at 20 °C

Direct current resistance	max.	84 Ω/km
Insulation resistance	min.	5 GΩ x km
Mutual capacitance	approx.	42.5 pF/m
Signal tempo (c)	approx.	0.72
Propagation delay	approx.	460 ns/100 m
Skew at 100 MHz	approx.	7 ns/100 m
Charact. impedance	at 100 MHz	100 ± 5 Ω
Testing voltage U _{eff}		1000 V
Operating voltage	max.	125 V

Thermal properties

For fixed installation	-40 °C to +70 °C
For mobile operation	-10 °C to +50 °C

Chemical characteristics

Free of hazardous substances acc. to RoHS 2011/65/EU
Oil resistance acc. to EN 60811-2-1
Ozone resistance acc. to EN 60811
Microbe resistance acc. to DIN VDE 0282
Chemical resistance
Hydrolysis resistance acc. to DIN 53504
Free of lacquer-wetting substances (e.g. silicon oil)

Cable printing

LEONI MegaLine F6-70 S/F flex 4P 11Y SPICE Code "xxxxx"
Made in Germany "Batch number" "Metre marking"

Colour code

WH/BU, WH/OG, WH/GN, WH/BN

Certificates and approvals

Link performance: LEONI MegaLine® systems
and other commonly available connector systems
Test certificates: according to DIN 55350-18-4.2.1 or EN 10204
Compliant with LVD (2014/35/EU): 

Dimension	Outer Ø approx.	Weight approx.	Copper no.*	Sheath colour	Order no.
	mm	kg/km	kg/km		
4P	8.8	73	35	● Rape yellow	LKD 7KS7 0139 xxxx

Packaging: xxxx

Standard length: 0100 = 1000 m 0000 = general

* see page 17: Definition of copper no.

MegaLine® D1-20 SF/U flex CI

Category 5



Type KS-v2Y(ST+C)H CI 1x4xAWG 22/7



Advantages

- Better than Category 5
- bandwidth 200 MHz
- excellent shielding characteristics
- Circuit integrity
- RoHS and REACh conformity

System integrity on exposure to fire for at least.

90 minutes

Construction for 4P

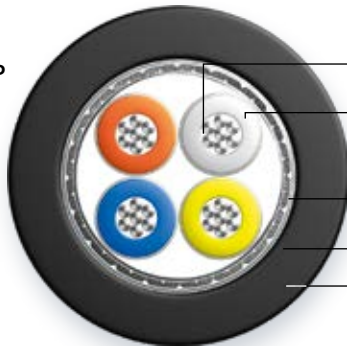

Conductor	bare copper wire, AWG 22/7
Insulation	PE core
Twisting element	Fire protection foil
Taping	4 cores
Overall shielding	Aluminium bonded polyester foil and copper braiding, optical coverage approx. 85 %
Taping	Fire protection foil
Outer sheath	halogen-free, flame-retardant compound

Fire behaviour

Flame retardancy	acc. to IEC 60332-3-24 / EN 50266-2-4
Halogen free	acc. to IEC 60754-1/2
Smoke density	acc. to IEC 61034-1/2
Fire load (reference value)	0.5 MJ/m

Performance

Better than Category 5 acc. to EN 50288 and IEC 61156
excellent shielding characteristics, circuit integrity acc. to FE90 IEC 60331-23,
bandwidth (typical) 200 MHz

Applications

Installation cable with circuit integrity for use in structured cabling acc. to ISO/IEC 11801 and EN 50173 (3rd Edition).
Ideal for all applications of Classes D up to 1 GbE acc. to IEEE 802.3 ab, cable sharing, VoIP, PoE/PoE+ and for fire alarm systems.

Mechanical characteristics

Bending radius during installation	8 x outer diameter (min.)
after installation	4 x outer diameter (min.)
Tensile strength (max.)	60 N
Crush strength	1000 N/100 mm
Impact strength (number of shocks)	10

Electromagnetic behaviour

Coupling resistance at 10 MHz (nom.)	5 mΩ/m
Shield attenuation up to 1000 MHz (nom.)	60 dB
Coupling attenuation up to 1000 MHz (nom.)	85 dB
Separating class acc. to EN 50174-2	d

Security (fire behaviour)

S	1	2	3	4	5
	IEC 60332-2-2	IEC-60332-1-2	IEC-60332-3-24	EFP Grade 1	EFP Grade 2

Performance (cable class, bandwidth)

P	1	2	3	4	5
	> Class E	> Class E _x	> Class F	> Class F _x	> Class F _{x+}
	> 250 MHz	> 500 MHz	> 600 MHz	> 1000 MHz	> 1200 MHz

Industrial application (ethernet, TV)

I	1	2	3	4	5
	> 100 MbE	> 1 GbE	up to 10 GbE	> 10 GbE	> 10 GbE TV

Construction (conductor dimension, tensile strength)

C	1	2	3	4	5
	AWG 27	AWG 26/25	AWG 24	AWG 23	AWG 22

EMC (coupling attenuation)

E	1	2	3	4	5
	> 40 dB	> 50 dB	> 60 dB	> 70 dB	> 80 dB

Electrical characteristics (HF) at 20 °C

Frequency MHz	Attenuation dB/10m		NEXT dB		PS-NEXT dB		ACR dB at 10m		PS-ACR dB at 10m		EL-FEXT dB at 100 m		PS-ELFEXT dB at 10m		RL dB	
	typ.	Cat. 5 max.*	typ.	Cat. 5 min.*	typ.	Cat. 5 min.*	typ.	Cat. 5 min.*	typ.	Cat. 5 min.*	typ.	Cat. 5 min.*	typ.	Cat. 5 min.*	typ.	Cat. 5 min.*
1	2	2.1	75	65	72	62	73	63	70	60	89	64	86	61	24.8	-
4	3.1	4	69	56	66	53	66	52	63	49	84	52	81	49	28.6	23
10	5.1	6.3	62	50	59	47	57	44	54	41	76	44	73	41	33.3	25
16	7	8	58	47	55	44	51	39	48	36	70	40	67	37	34.3	25
31.25	9.7	11.4	53	43	50	40	44	31	41	28	63	34	60	31	33.9	23.6
62.5	13.2	16.5	49	38	46	35	36	22	33	19	58	28	55	25	31.3	21.5
100	17.6	21.3	45	35	42	32	28	14	25	11	52	24	49	21	27.7	20.1
155	22.3	-	42	-	39	-	20	-	17	-	49	-	46	-	24.7	-
200	26.5	-	40	-	37	-	14	-	11	-	45	-	42	-	22.4	-

* EN 50288-2-1(2004)/IEC 61156-5 (2009)

Electrical characteristics (LF) at 20 °C

Direct current resistance	max.	120 Ω/km
Insulation resistance	min.	5 GΩ x km
Signal tempo (c)	approx.	0.65
Propagation delay	approx.	530 ns/100 m
Skew at 100 MHz	approx.	15 ns/100 m
Charact. impedance	at 100 MHz	100 ± 5 Ω
Testing voltage U _{eff}		700 V
Operating voltage	max.	80 V

Thermal properties

For fixed installation	-20 °C to +60 °C
For mobile operation	0 °C to +50 °C

Chemical characteristics

Free of hazardous substances acc. to RoHS 2011/65/EU

Cable printing

LEONI MegaLine D1-20 SF/U flex 1Q H SPICE Code "xxxxx" FIRE RESISTANT FE90 IEC 60331-23 "Batch number" "Metre marking"

Colour code

WH, YE, BU, OG

Certificates and approvals

Link performance: LEONI MegaLine® systems

and other commonly available connector systems

Test certificates: according to DIN 55350-18-4.2.1 or EN 10204

Compliant with LVD (2014/35/EU): **CE**

Dimension	Outer Ø approx.	Weight approx.	Copper no.*	Sheath colour	Order no.
	mm	kg/km	kg/km		
4P	6.5	62	30	● Jet black	LKD 7KS5 0075 xxxx

Packaging: xxxx

Standard length: 0100 = 1000 m 0000 = general

* see page 17: Definition of copper no.

MegaLine® D1-20 S/U 11Y superflex

Category 5

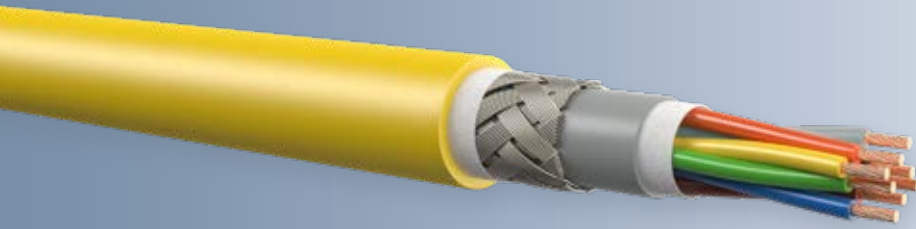

Type KS-6Y3GC11Y 4x2xAWG 26/19



Advantages

- Better than Category 5
- bandwidth 100 MHz
- good shielding characteristics
- suitable for use with drag chains
- RoHS and REACH conformity

Construction for 4P

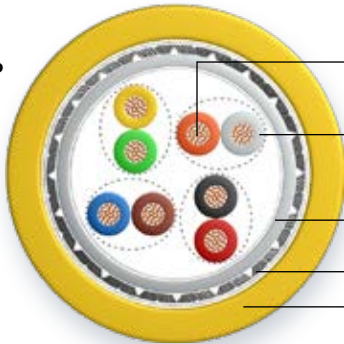

Conductor	bare copper wire, AWG 26/19
Insulation	FEP, core Ø: nominal value 1.0 mm
Twisting element	Pair
Twisting	4 pairs
Taping	Fleece foiling
Inner sheath	EPDM
Taping	Fleece foiling
Overall shielding	copper braiding, optical coverage approx. 90 %
Outer sheath	PUR

Fire behaviour

Flame retardancy acc. to IEC 60332-2-2
Fire load (reference value) 0.7 MJ/m

Performance

Better than Category 5 acc. to EN 50288 and IEC 61156
excellent shielding properties, bandwidth (typical) 100 MHz

Applications

Connection cable and patch cord for use in structured cabling acc. to ISO/IEC 11801 and EN 50173 (3rd Edition). Ideal for all applications of Classes D up to 1 GbE acc. to IEEE 802.3 ab, VoIP, PoE/PoE+.
For use in harsh environments due to very rugged EPDM inner sheath and highly rugged PUR outer sheath. Suitability for drag chain use (Type 5 million cycles).
Torsional suitability acc. to EN 50289-3-10. Suitable for use in cleanrooms of air purity class 2 acc. to ISO 14644-1

Mechanical characteristics

Bending radius in operation	5 x outer diameter (min.)
Tensile strength (max.)	60 N
Crush strength	2000 N/100 mm
Impact strength (number of shocks)	20

Electromagnetic behaviour

Coupling resistance at 10 MHz (nom.)	100 mΩ/m
Shield attenuation up to 1000 MHz (nom.)	55 dB
Coupling attenuation up to 1000 MHz (nom.)	75 dB
Separating class acc. to EN 50174-2	c

Security (fire behaviour)

S	1	2	3	4	5
	IEC 60332-2-2	IEC-60332-1-2	IEC-60332-3-24	EFP Grade 1	EFP Grade 2

Performance (cable class, bandwidth)

P	1	2	3	4	5
	> Class E > 250 MHz	> Class E _A > 500 MHz	> Class F > 600 MHz	> Class F _A > 1000 MHz	> Class F _{A+} > 1200 MHz

Industrial application (ethernet, TV)

I	1	2	3	4	5
	> 100 MbE	> 1 GbE	up to 10 GbE	> 10 GbE	> 10 GbE TV

Construction (conductor dimension, tensile strength)

C	1	2	3	4	5
	AWG 27	AWG 26/25	AWG 24	AWG 23	AWG 22

EMC (coupling attenuation)

E	1	2	3	4	5
	> 40 dB	> 50 dB	> 60 dB	> 70 dB	> 80 dB

Electrical characteristics (HF) at 20 °C

Frequency MHz	Attenuation dB/10m		NEXT dB		PS-NEXT dB		ACR dB at 10m		PS-ACR dB at 10m		EL-FEXT dB at 10m		PS-ELFEXT dB at 10m		RL dB	
	typ.	Cat. 5 max.*	typ.	Cat. 5 min.*	typ.	Cat. 5 min.*	typ.	Cat. 5 min.*	typ.	Cat. 5 min.*	typ.	Cat. 5 min.*	typ.	Cat. 5 min.*	typ.	Cat. 5 min.*
1	0.22	0.32	80	65	77	62	80	65	77	62	80	64	77	61	27	–
4	0.58	0.60	67	56	64	53	67	56	64	53	69	52	66	49	26	23
10	1.1	1.05	63	50	60	47	62	49	59	47	61	44	65	58	30	25
16	1.4	1.45	61	47	58	44	60	46	57	44	56	40	53	37	30	25
20	1.6	1.6	59	46	56	43	58	44	55	43	53	38	50	35	30	25
31.25	2.1	2	57	43	54	40	55	41	52	40	48	34	45	31	30	23.6
62.5	3.2	3	52	38	49	35	50	36	47	35	43	28	40	25	28	21.5
100	4.2	4	45	35	42	32	42	32	39	32	38	24	35	21	26	20.1

* based on EN 50288-2-2 (2004)/IEC 61156-6 (2010)

Electrical characteristics (LF) at 20 °C

Direct current resistance	max.	130 Ω/km
Insulation resistance	min.	5 GΩ x km
Mutual capacitance	approx.	50 pF/m
Signal tempo (c)	approx.	0.68
Propagation delay	approx.	490 ns/100 m
Skew at 100 MHz	approx.	15 ns/100 m
Charact. impedance	at 100 MHz	100 ± 5 Ω
Testing voltage U _{eff}		1000 V
Operating voltage	max.	125 V

Thermal properties

For fixed installation	–40 °C to +85 °C
For mobile operation	0 °C to +50 °C

Cable printing

LEONI MegaLine D1–20 S/U superflex 4P 11Y SPICE Code "xxxxx"
Made in Germany "Batch number" "Metre marking"

Chemical characteristics

Free of hazardous substances acc. to RoHS 2011/65/EU
Oil resistance acc. to EN 60811-2-1
Ozone resistance acc. to EN 60811
Cleanability acc. to riboflavin test (VDMA)
Microbe resistance acc. to DIN VDE 0282
Chemicals resistance acc. to ISO 2812-1 and ISO 4628-1: excellent
Hydrolysis resistance acc. to DIN 53504
Free of lacquer-wetting substances (e.g. silicon oil)
Emissions response of TVOC according to ISO 14644-8: ISO-AMCm-8,1

Colour code

GY/OG, BK/RD, GNYE, BU/BN

Certificates and approvals

Quality mark with production control:
Fraunhofer IPA Tested Device Report No. LE 1212-626
Link performance: LEONI MegaLine® systems
and other commonly available connector systems
Test certificates: according to DIN 55350-18-4.2.1 or EN 10204
Compliant with LVD (2014/35/EU): 

Dimension	Outer Ø approx.	Weight approx.	Copper no.*	Sheath colour	Order no.
	mm	kg/km	kg/km		
4P	6.8	58	28.6	● Rape yellow	LKD 7KS5 0051 xxxx

Packaging: xxxx

Standard length: 0100 = 1000 m 0000 = general

* see page 17: Definition of copper no.

MegaLine® home 600

Category 7



Type KS-02YSCH 4x2xAWG 26/1 PIMF

Advantages

- Category 7 up to 65 m
- highly flexible, thin and light
- white sheath, perfect for your home

Construction for 4P

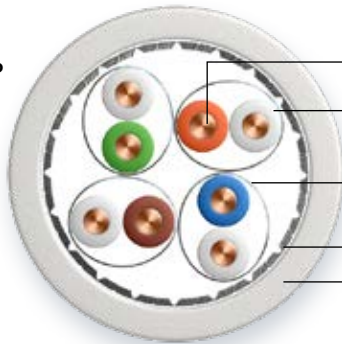

Conductor	Bare copper wire, AWG 26/1
Insulation	Cellular PE, core Ø: nominal value 1.0 mm
Twisting element	Pair
Individual shielding	Aluminium bonded polyester foil, metal on the outside (PIMF)
Twisting	4 pairs
Overall shielding	Tinned copper braid
Outer sheath	halogen-free, flame-retardant compound

Fire behaviour

Flame retardancy	acc. to IEC 60332-1-2
Halogen free	acc. to IEC 60754-1/2
Smoke density	acc. to IEC 61034-1/2
Fire load (reference value)	0.4 MJ/m
EU Construction Products Regulation	acc. to EN 50575 / EN 50399

Performance

Better than Category 7 acc. to EN 50288 and IEC 61156, excellent NEXT, excellent shielding characteristics (pairs and overall shielding), low skew. High degree of installation comfort and space-saving due to small diameter and tending radius as well as low weight. Bandwidth (typical) 700 MHz

Applications

Installation cable for household cabling.
Ideal for all applications of Classes D bis F, multimedia (video, data voice) > 10 GbE acc. to IEEE 802.3 an, cable sharing, VoIP, PoE.
For transmission links of max. 65 m.

Mechanical characteristics

Bending radius during installation	8 x outer diameter (min.)
after installation	4 x outer diameter (min.)
Tensile strength (max.)	50 N
Crush strength	1000 N/100 mm
Impact strength (number of shocks)	10

Electromagnetic behaviour

Coupling resistance at 10 MHz (nom.)	5 mΩ/m
Shield attenuation up to 1000 MHz (nom.)	70 dB
Coupling attenuation up to 1000 MHz (nom.)	85 dB
Separating class acc. to EN 50174-2	d

Security (fire behaviour)

S	1 IEC 60332-2-2	2 IEC-60332-1-2 E _{ca} /D _{ca}	3 IEC-60332-3-24 E _{ca} /D _{ca}	4 EFP Grade 1 C _{ca}	5 EFP Grade 2 B2 _{ca}
----------	--------------------	--	---	-------------------------------------	--------------------------------------

Performance (cable class, bandwidth)

P	1 > Class E > 250 MHz	2 > Class E _A > 500 MHz	3 > Class F > 600 MHz	4 > Class F _A > 1000 MHz	5 > Class F _{A+} > 1200 MHz
----------	-----------------------------	--	-----------------------------	---	--

Application (ethernet, TV)

A	1 > 100 MbE	2 > 1 GbE	3 up to 10 GbE	4 > 10 GbE	5 > 10 GbE TV
----------	----------------	--------------	-------------------	---------------	------------------

Construction (conductor dimension, tensile strength)

C	1 AWG 27	2 AWG 26/25	3 AWG 24	4 AWG 23	5 AWG 22
----------	-------------	----------------	-------------	-------------	-------------

EMC (coupling attenuation)

E	1 > 40 dB	2 > 50 dB	3 > 60 dB	4 > 70 dB	5 > 80 dB
----------	--------------	--------------	--------------	--------------	--------------

Electrical characteristics (HF) at 20 °C

Frequency MHz	Attenuation dB/10m		NEXT dB		PS-NEXT dB		ACR dB at 10m		PS-ACR dB at 10m		EL-FEXT dB at 10m		PS-ELFEXT dB at 10m		RL dB	
	typ.	Cat. 7 max.*	typ.	Cat. 7 min.*	typ.	Cat. 7 min.*	typ.	Cat. 7 min.*	typ.	Cat. 7 min.*	typ.	Cat. 7 min.*	typ.	Cat. 7 min.*	typ.	Cat. 7 min.*
1	0.25	0.29	100	80	97	77	100	80	97	77	100	80	97	80	24	23
10	0.76	0.85	99	80	96	77	99	79	96	77	95	74	92	71	33.9	25
100	2.49	2.78	95	72	92	69	93	70	90	69	69	54	66	51	38.3	20.1
200	3.69	4.01	92	68	89	65	88	64	85	65	65	48	62	45	35.3	18
250	4.18	4.53	90	66	87	63	86	62	83	63	62	46	59	43	32.9	17.3
500	5.6	6.62	83	62	80	59	78	55	75	59	54	40	51	37	29.7	17.3
600	6.74	7.33	81	61	78	58	74	53	71	58	50	38	47	35	30.6	17.3
700	7.32	-	80	-	77	-	72	-	69	-	50	-	47	-	31	-

* EN 50288-4-2 (2014)/IEC 61156-6 (2010)

Electrical characteristics (LF) at 20 °C

Direct current resistance	max.	145 Ω/km
Insulation resistance	min.	5 GΩ x km
Mutual capacitance	approx.	44 pF/m
Capacitive coupling (e)	approx.	1100 pF/km
Signal tempo (c)	approx.	0.71
Propagation delay	approx.	440 ns/100 m
Skew at 100 MHz	approx.	5 ns/100 m
Charact. impedance	at 100 MHz	100 ± 5 Ω
Testing voltage U _{eff}		1000 V
Operating voltage	max.	125 V

Thermal properties

For fixed installation	-20 °C to +60 °C
For mobile operation	0 °C to +50 °C

Chemical characteristics

Free of hazardous substances acc. to RoHS 2011/65/EU



Cable printing

LEONI MegaLine home 600 Made in Germany "CPR Class" "DoP no." "Batch number" "Metre marking"

Colour code

WH/BU, WH/OG, WH/GN, WH/BN

Certificates and approvals

Link performance: Excellently suited for use with MegaLine® Connect45 and MegaLine® patch connection components
Compliant with LVD (2014/35/EU): 
Compliant with Construction Products Regulation (EU/305/2011): 

Dimension	Outer Ø approx.	Weight approx.	Copper no.*	CPR class	DoP no.	Sheath colour	Order no.
	mm	kg/km	kg/km				
4P	5.7	39	20	D _{ca} s2 d2 a1	CDESK0000031	○ Signal white	LKD 7K57 0304 xxxx

Packaging: xxxx

Standard length: 0100 = 1000 m 0035 = 305 m 0010 = 100 m 0000 = general

* see page 17: Definition of copper no.

MegaLine® Connect100

Cu connectivity

Upgrade your performance
to Cat. 6_A, 7, 7_A, 8.2...

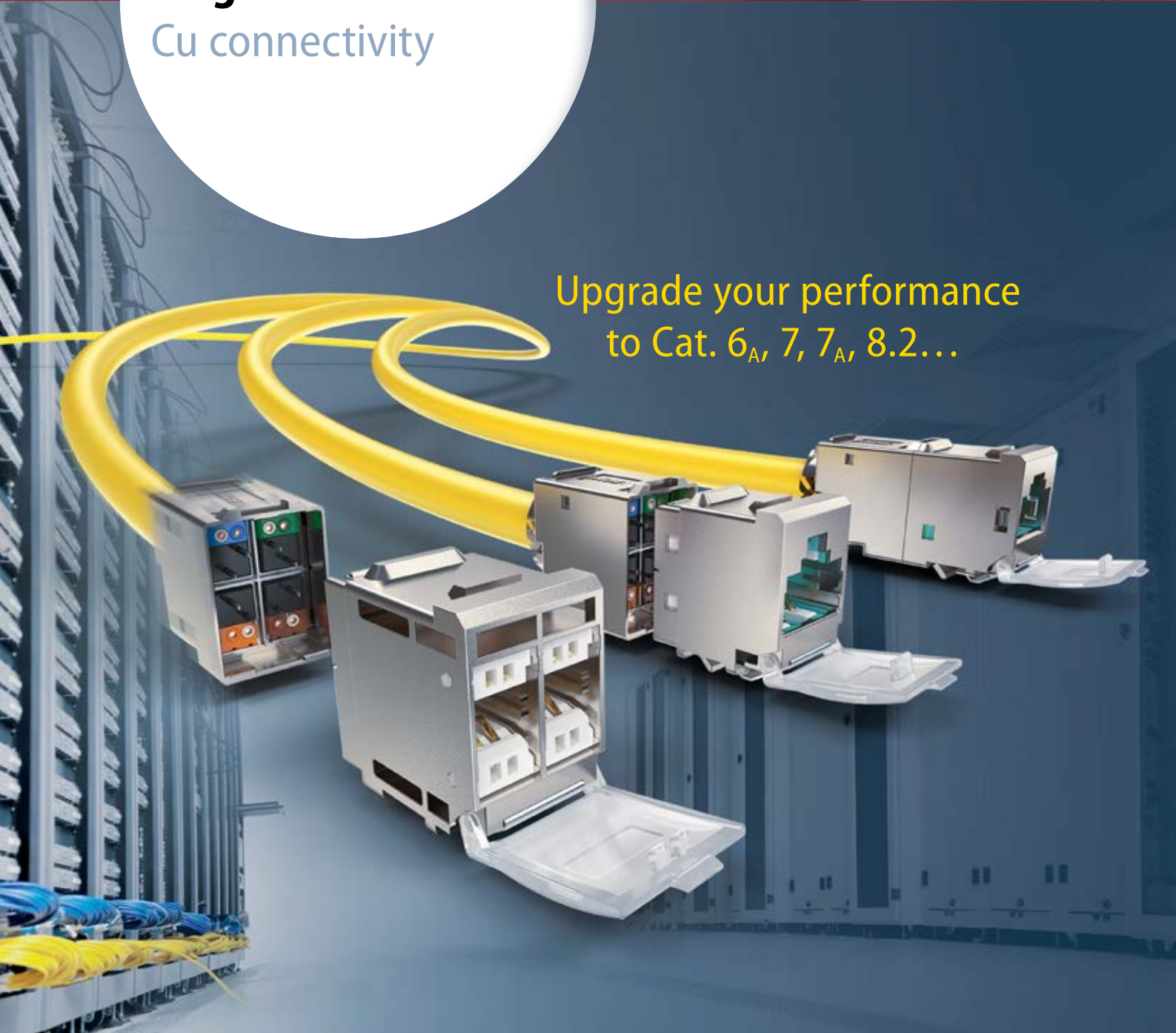

MegaLine® Connect100

The cabling system from 10 – 40 Gbit/s

MegaLine® Connect100 Cu connectivity			page
	Ready for 40 Gbit/s Perfection in efficiency, future-orientation & electrical performance		106
	40 GBASE-T over copper		108
	The cabling system from 10 – 40 Gbit/s – system overview		110
o dc	Cable plug	<ul style="list-style-type: none"> • Cable plug Cat. 7_A • Cable plug flex Cat. 7_A 	112
o dc	Jack modules	<ul style="list-style-type: none"> • Jack module 8C7A Cat. 7_A • Jack module 4K7A Cat. 7_A • Jack module RJ45 Cat. 6_A 	113
o dc	Interface	<ul style="list-style-type: none"> • Interface • Interface connector solid / flex 	114
o dc	Wall outlets for MegaLine® Connect100 jack modules	<ul style="list-style-type: none"> • 50 x 50 • 45 x 45 	115
o dc	Modular patch panel set 19" / 1RU		116
o dc	Patch panel 19"	unequipped	117
o dc o	DIN rail housing	dual, with DIN rail clip	117
	MegaLine® accessories & cable assembly tools	<ul style="list-style-type: none"> • Blind cover • Dust cap • Wadeless side cutter • Crimping tool • Stripping tool • Assembly aid • Test adapter 	118
o	Office		
dc	DataCenter		
o	Industry		

MegaLine® – Ready for 40 GBit/s

Perfection in efficiency, future-orientation & electrical performance

The MegaLine® comprises the new G20 S/F and G20 S/F flex data cable and the 40-Gbit/s-compatible MegaLine® Connect100 cable plug. The connection is created as required by simply plugging in the desired jack module (RJ45, ARJ45™, TERA™, interface).



MegaLine® data cable Cat. 7_A

assembled
cable plug Cat. 7_A

The desired jack module is
simply connected – done

**MegaLine® G20 S/F acc. to IEC 61156-9
Cat.8.2**

IEC 60603-7-51
Cat. 6_A
10 Gbit/s

IEC 61076-3-110
Cat. 7_A (up to 2 GHz)
25 / 40 GBit/s

IEC 61076-3-104
Cat. 7_A (up to 2 GHz)
25 / 40 GBit/s

IEC 61076-3-104
Cat. 7_A (up to 2 GHz)
25 / 40 GBit/s

Economy >>

- Unique cable connection with multiple uses
- Replaceable jack modules
- Varying performance
- Low maintenance and service costs
- Short assembly and upgrade time
- Pre-assembled links (low downtime)

Performance >>

Ready for 25 / 40 GBASE-T

Easy to assemble >>

- Unique cable connection with multiple uses
- Modular construction
- Pre-assembled links

Outstanding quality >>

Independently monitored by the
GHMT Premium Verification Program



The combination of high-quality individual components is reflected in the results of the channel measurement (class II). According to the current Edition of ISO/IEC 11801 (3rd edition), good reserves are achieved.

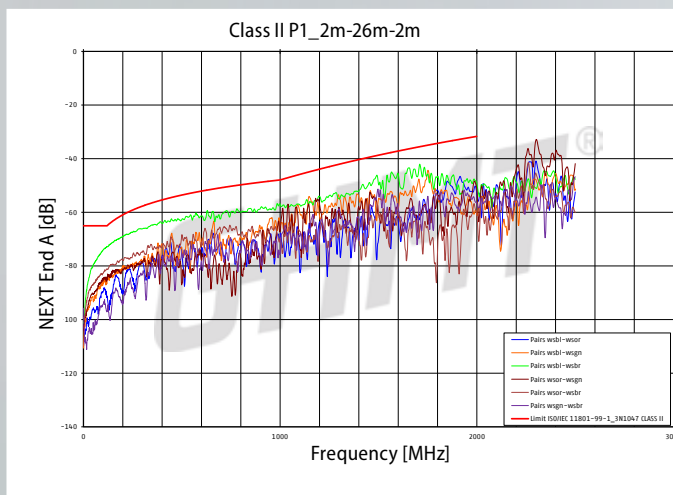
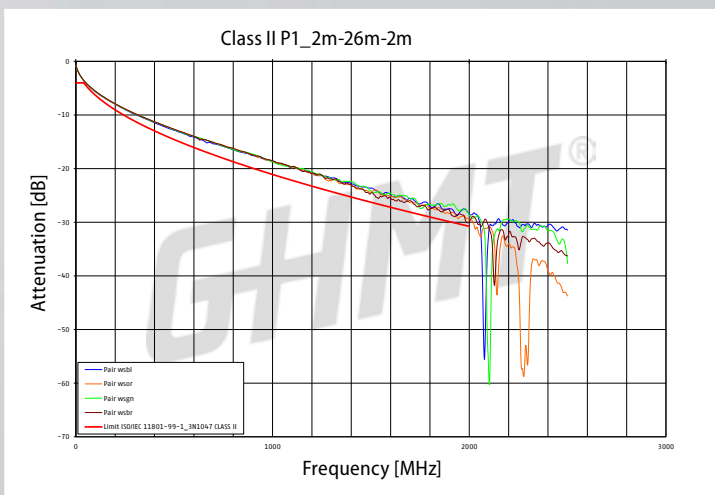
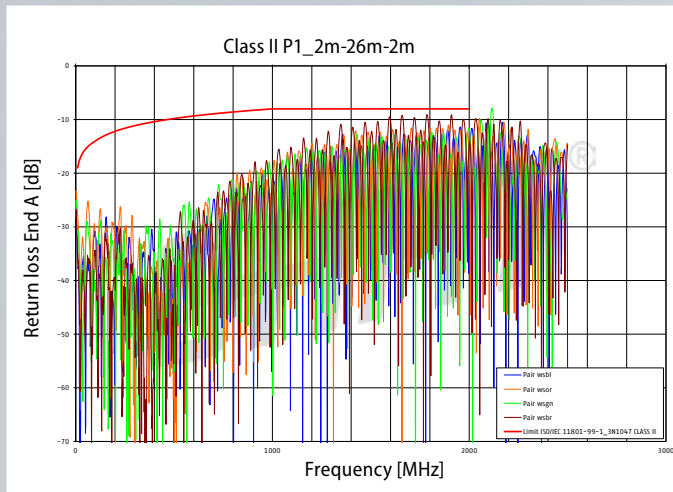

Technological leap: 40 GBASE-T

The next 40 GBASE-T technological leap, driven by the demand for increasingly higher performance on the active component side, requires the technological improvement of passive system technology.

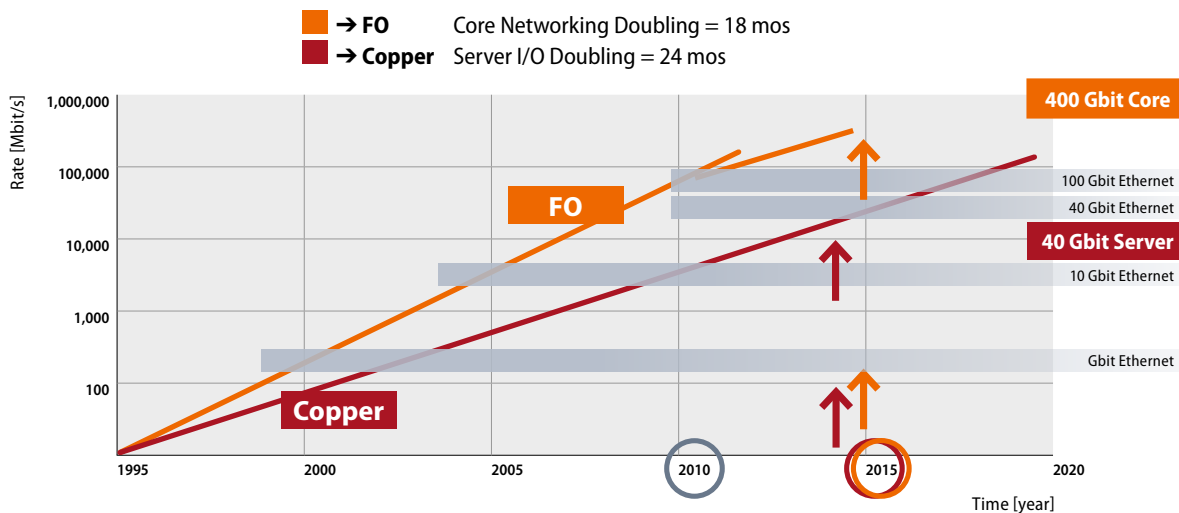

MegaLine® – 40 GBASE-T over copper

40 GBASE-T system technology areas of application: End of Row / Top of Rack topology:

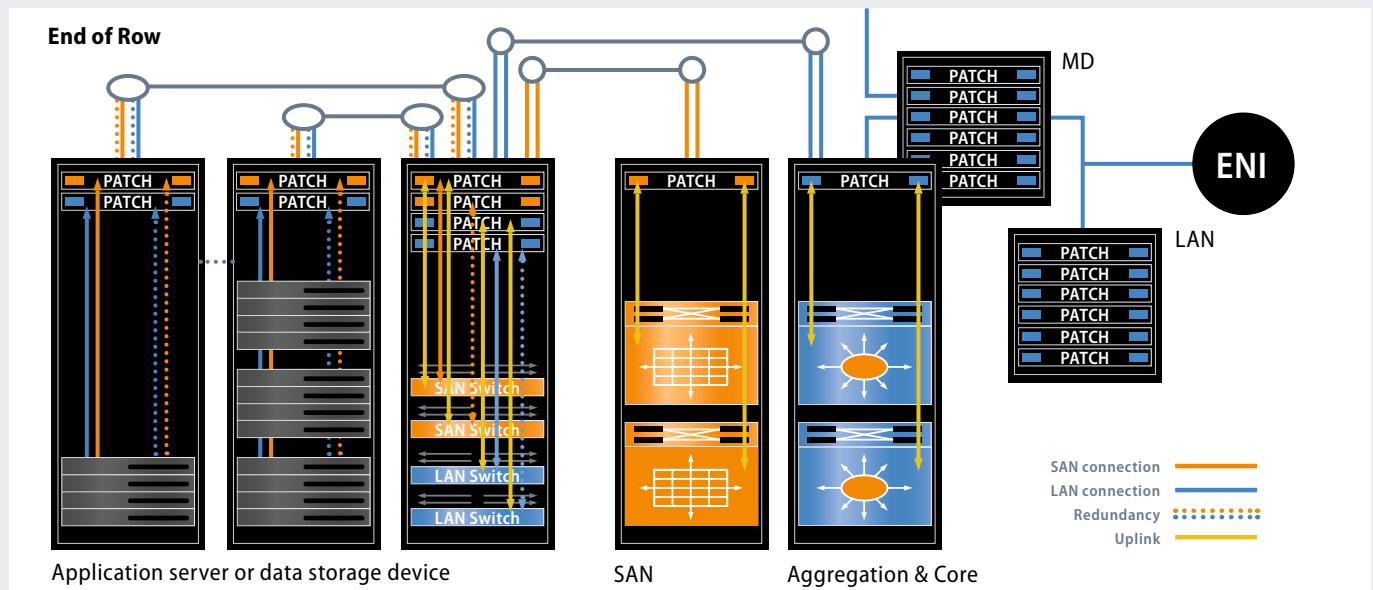

The requirements for the following transmission links in the data center are specified under the designation IEEE 802.3bq:

- EoR/MoR: Server switch links of up to 30 m with 2 connectors
- ToR: "Port to Port2 links using patch cords of 5 m to 10 m

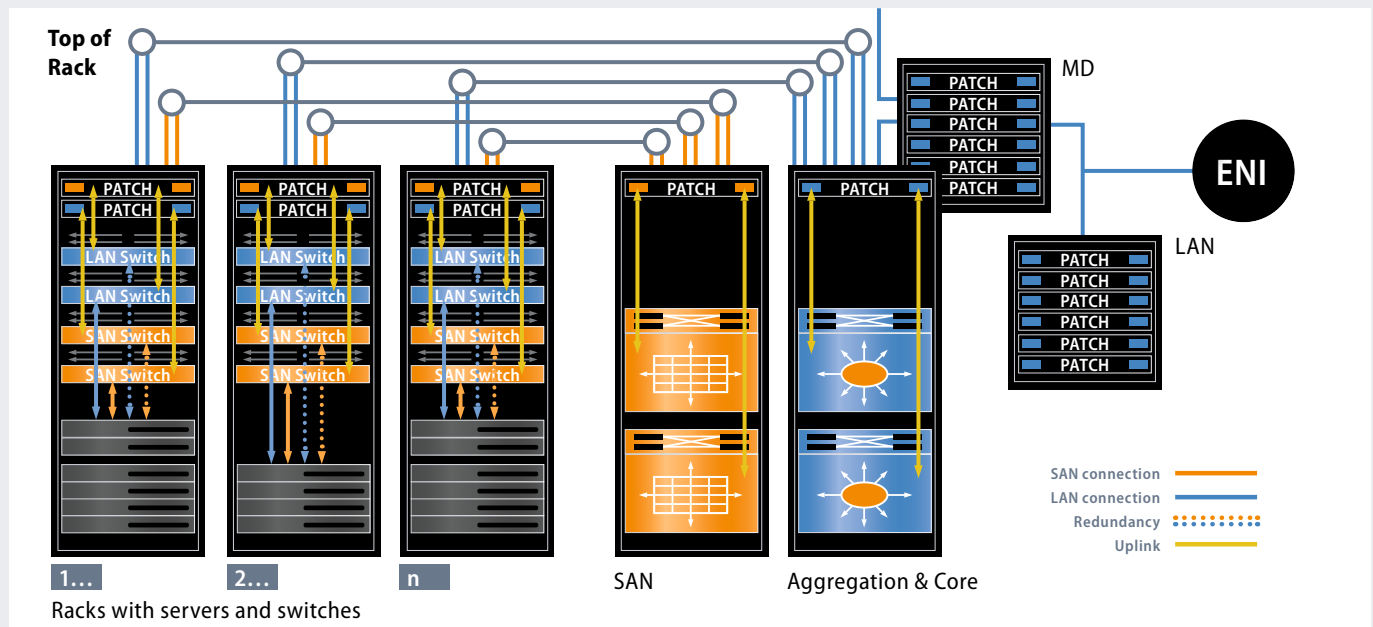

The reasons for the introduction of the new Ethernet standards mainly include the deficits of existing solutions according to IEEE 802.3ba for 40 GBit/s applications:

- Range limitation to 7 m with 8-pair CR4 Twinax cables (Top-of-Rack cabling)
- Reduced cost efficiency and migration capability with 8-fiber OM3 / OM4 FO cables (End-of-Row cabling)
- Poor economic efficiency of 2-fiber SM-FO cables (1310 CWDM / 1550 nm) up to 10 km / 2 km

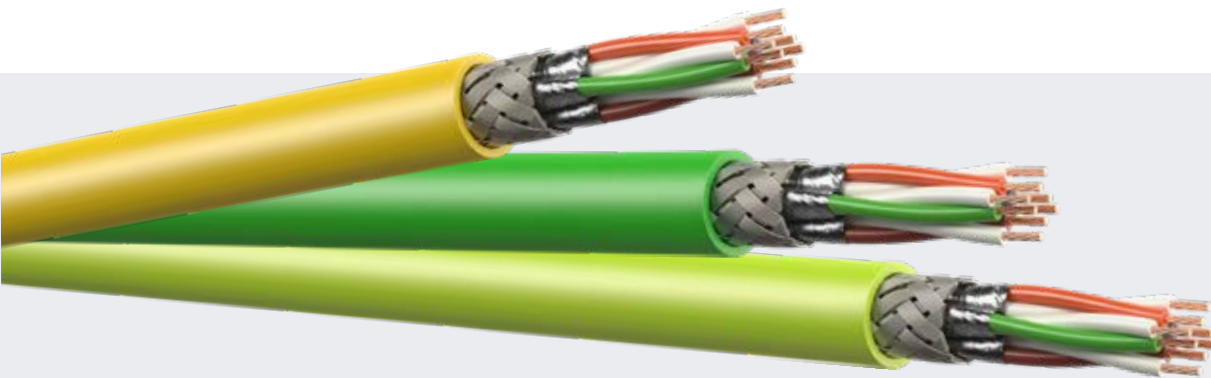

S/FTP
Category 8.2



Interface, TERA™, GG45™, ARJ45™
Category 8.2

Conclusion: Cat.8.2 – the solution for 40 GBASE-T

The Technical Report ISO/IEC 11801-99-1 (draft) recommends the following for the realisation of 40 Gbit/s over 4-pair cabling:

- Class I (based on Cat. 8.1 components)
- Class II (based on Cat. 8.2 components)

The technical superiority of Class II

(with Category 8.2 components) derives from the much higher reserves available with NEXT, PSNEXT, ACR-F and PSACR-F.

Additional advantages:

- Only components of Category 8.2 offer reserve compatibility with Cat. 7 and Cat.7_A
- Category "8.2" components offer reserves for further data increases

Class II cabling is the more cost-effective solution due to the lower design costs of the active technology (lower compensation expenditures). The cost of Cat. 8.1 or Cat. 8.2 cables is assumed to be being equal.

MegaLine® – the cabling system from 10 – 40 Gbit/s

System overview

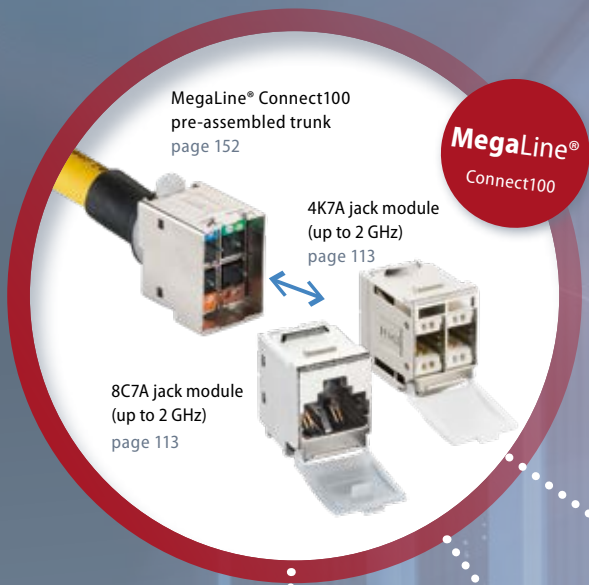

MegaLine® Connect100 pre-assembled trunk page 152

4K7A jack module (up to 2 GHz) page 113

8C7A jack module (up to 2 GHz) page 113

MegaLine®
Connect100



VariLine® UF Underfloor systems page 169

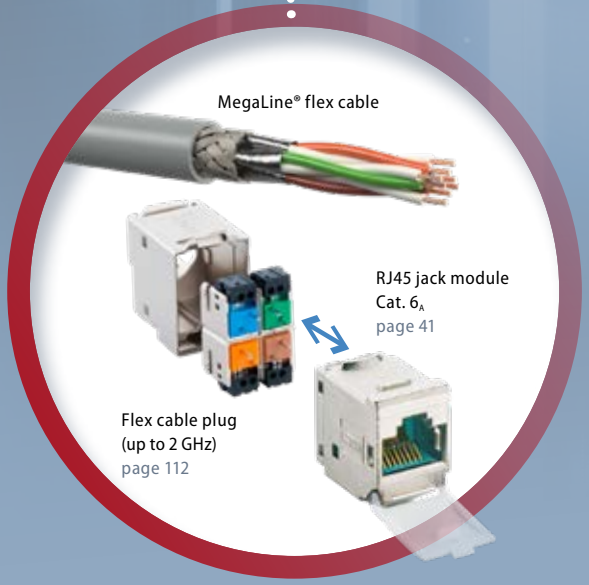

MegaLine® flex cable

RJ45 jack module Cat. 6_A page 41

Flex cable plug (up to 2 GHz) page 112

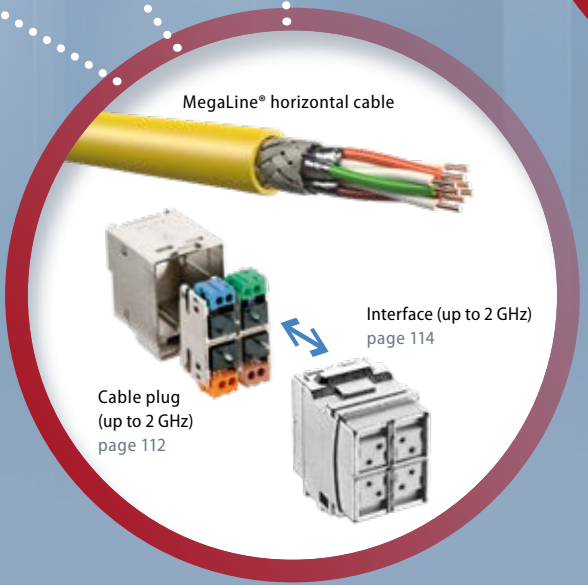

MegaLine® horizontal cable

Cable plug (up to 2 GHz) page 112

Interface (up to 2 GHz) page 114

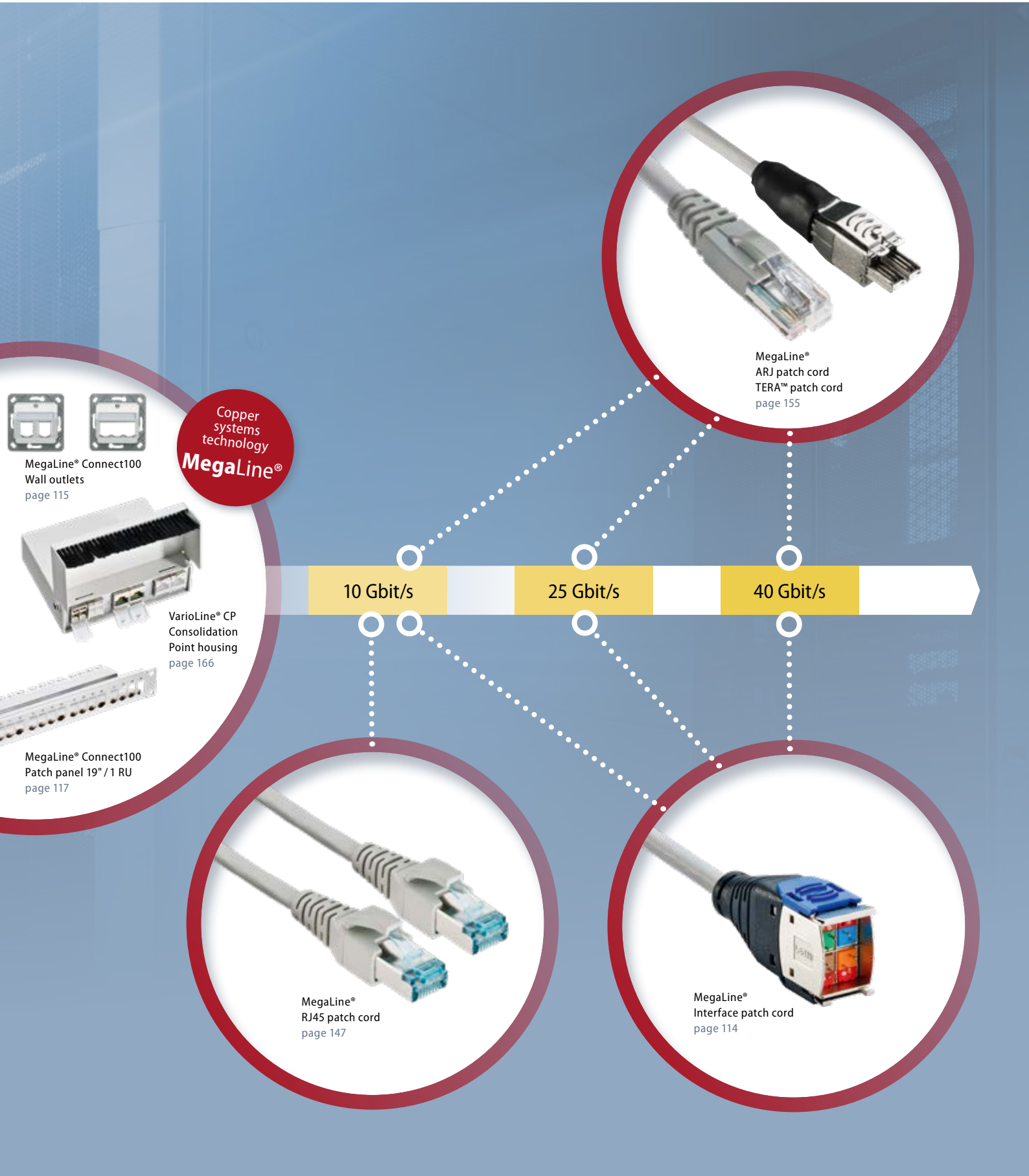

MegaLine® Connect100 cable plug

Category 7_A

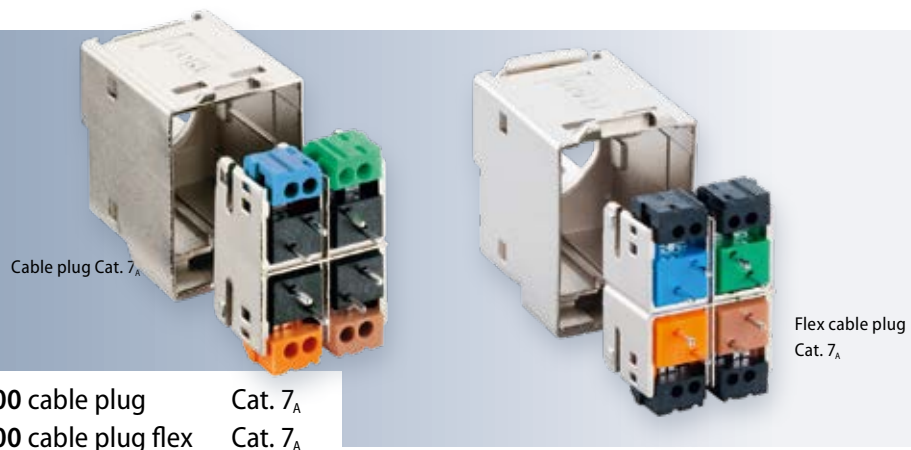

MegaLine® Connect100 cable plug Cat. 7_A
 MegaLine® Connect100 cable plug flex Cat. 7_A

Description

Interface for individually interchangeable MegaLine® Connect100 jack module. The cable plug enables generic transmission links far exceeding the requirements for Class F_A to be achieved. The mating face can also be identified later without any additional installation effort.

- Various mating faces available
- Simple and fast assembly

Construction

Material	PC; die-cast zinc, nickel-plated
Wiring	4 pairs via punchdown method
Strain relief	via cable ties
Shielding	extensive 360° shield connection
Electrical values	Class F _A / Category 7 _A / bis 2 GHz

Electrical characteristics

Contact resistance	≤ 20 Ω	
Isolation resistance	≥ 500 MΩ	between contacts
Proof voltage	≥ 1000 V DC/AC	contact – contact
	≥ 1500 V DC/AC	contact – shielding
Max. current	1.25 A at 50° C	

Standards

- ISO/IEC 11801
- EN 50173-1
- IEEE 802.3af/at (PoE/PoE+)

Article	Category	Order no.
MegaLine® Connect100 Cable plugs (AWG 24-22 solid)	Cat. 7 _A (up to 2 GHz)	LKD 9A90 2330 0000
MegaLine® Connect100 Cable plugs flex (AWG 27-26 flex)		LKD 9A90 2331 0000

MegaLine® Connect100 jack modules

Category 7_A/6_A



Jack module
Cat. 7_A (up to 2 GHz)

Jack module
Cat. 7_A (up to 2 GHz)



Jack module
Cat. 6_A

MegaLine® Connect100 jack module 8C7A / 4K7A

Description

For transmitting analogue and digital voice, image and data signals. The performance features correspond to Category 7_A (up to 2 GHz).

Construction

Material	Full metal; die-cast zinc, nickel-plated
Installation dimensions	according to the installation dimensions of the RJ45 jack module and therefore interchangeable
Wiring	4 pairs via cable plug
Connection	Jack 8C7A/4K7A

Standards

- ISO/IEC 11801
- EN 50173-1
- EN 61076-3-110 & EN 61076-3-104
- IEEE 802.3af/at (PoE/PoE+)

Accessories see page 118

Colour dust caps for coding of modules



Article	Category	Order no.
MegaLine® Connect100 Jack module 4K7A – white	Cat. 7 _A (up to 2 GHz)	LKD 9A90 2030 0000
MegaLine® Connect100 Jack module 8C7A – black		LKD 9A90 2020 0000

MegaLine® Connect100 jack module RJ45

Description

For transmitting analogue and digital voice, image and data signals. The performance features correspond to Category 6_A up to 500 MHz.

Construction

Material	Full metal; die-cast zinc, nickel-plated
Installation dimensions	according to the installation dimension of the 4K7A- / 8C7A jack module and therefore mutually exchangeable
Wiring	4 pairs via cable plug
Connection	Jack RJ45

Standards

- ISO/IEC 11801
- EN 50173-1
- IEC 60603-7-51
- IEEE 802.3af/at (PoE/PoE+)

Accessories see page 118

Colour dust caps for coding of modules



Article	Category	Order no.
MegaLine® Connect100 Jack module RJ45 – aqua	Cat. 6 _A	LKD 9A90 2010 0000

MegaLine® Connect100 Interface

Category 7_A (up to 2 GHz)



MegaLine® Connect100 Interface

Description

For transmitting analogue and digital voice, image and data signals. The performance features correspond to Category 7_A (up to 2 GHz).

Construction

Material	Full metal; die-cast zinc, nickel-plated
Installation dimensions	according to the installation dimensions of the RJ45 jack module and therefore interchangeable
Wiring	4 pairs via cable plug
Connection	Interface jack

Standards

- ISO/IEC 11801
- EN 50173-1
- IEEE 802.3af/at (PoE/PoE+)

Article	Category	Order no.
MegaLine® Connect100 Interface	Cat. 7 _A (up to 2 GHz)	LKD 9A90 2050 0000



MegaLine® Connect100 Interface connector solid / flex

Description

For transmitting analogue and digital voice, image and data signals. The performance features correspond to Category 7_A (up to 2 GHz).

Construction

Material	Full metal; die-cast zinc, nickel-plated
Wiring	4 pairs via cable plug
Connection	Interface connector

Standards

- ISO/IEC 11801
- EN 50173-1
- IEEE 802.3af/at (PoE/PoE+)

Article	Category	Order no.
MegaLine® Connect100 Interface connector solid (AWG24-22)	Cat. 7 _A (up to 2 GHz)	LKD 9A90 2051 0000
MegaLine® Connect100 Interface connector flex (AWG24-22)		LKD 9A90 2052 0000

MegaLine® Connect100 wall outlets

for MegaLine® Connect100 jack modules



Fig. 1
50 x 50 / 1-fold
wall outlet



Fig. 2
50 x 50 / dual
wall outlet

Fig. 3
50 x 50 / 3-fold
wall outlet



Fig. 4
Wall outlet
45 x 45 / 1-fold
(similar to fig.)



Fig. 5
Wall outlet
45 x 45 / dual (similar to figure)

MegaLine® Connect100 50 x 50 wall outlet

German design

Wall outlets for installation in commonly available 50 x 50 mm cover frames for fitting with MegaLine® Connect100 jack modules. Compatible with the jack modules MegaLine® Connect45 (VK format).

Housing

Housing body	Full metal; die-cast zinc, nickel-plated
Colours	Pure white, RAL 9010
Labelling	via labelling field

Installation dimensions

50 mm x 50 mm (H x W), downward inclination of 30°

Accessories (optional)

MegaLine® Connect100 1 and 2-fold cover frame
40 mm surface-mounted housing incl. 1-fold flush-mounted cover frame
Spacer frame for 1-fold surface-mounted housing, 10 mm

MegaLine® Connect100 45 x 45 wall outlet

French design

Wall outlets for fitting with MegaLine® Connect100 jack modules. Compatible with the jack modules MegaLine® Connect45 (VK format).

Housing











Housing body	Plastic
Colours	Pure white, RAL 9010
Labelling	via labelling field

Installation dimensions

45 mm x 45 mm x 42 mm (H x B x D), downward inclination 30°

Accessories (optional)

VarioLine® cover frame

Fig.	Article	Colour	Order no.
1	 MegaLine® Connect100 wall outlet 50 x 50 / 1-fold (1 pc.)	○ Pure white, RAL 9010	LKD 9A46 0107 0000
2	 MegaLine® Connect100 wall outlet 50 x 50 / dual (1 pc.)		LKD 9A46 0108 0000
3	 MegaLine® Connect100 wall outlet 50 x 50 / 3-fold (1 pc.)		LKD 9A46 0109 0000
-	 Flush-mounted cover frame 1-fold (1 pc.)	○ Pure white, RAL 9010	LKD 9A41 0003 0000
-	 Flush-mounted cover frame, 2-fold (1 pc.)		LKD 9A41 0005 0000
-	 Surface-mounted housing 40 mm incl. UP-cover frame 1-fold (1 pc.)		LKD 9A46 0086 0000
-	 Spacer frame for surface-mounted housing 1-fold 10 mm (1 pc.)		LKD 9A46 0088 0000
1	 MegaLine® Connect100 wall outlet 45 x 45 / 1-fold	○ Pure white, RAL 9010	LKD 9A90 1101 0000
2	 MegaLine® Connect100 wall outlet 45 x 45 / dual		LKD 9A90 1100 0000
3	 VarioLine® cover frame 45 x 45 (8)		LKD 9ZE8 0013 0000

MegaLine® Connect100 modular patch panel 19" / 1RU

for MegaLine® Connect100 jack modules

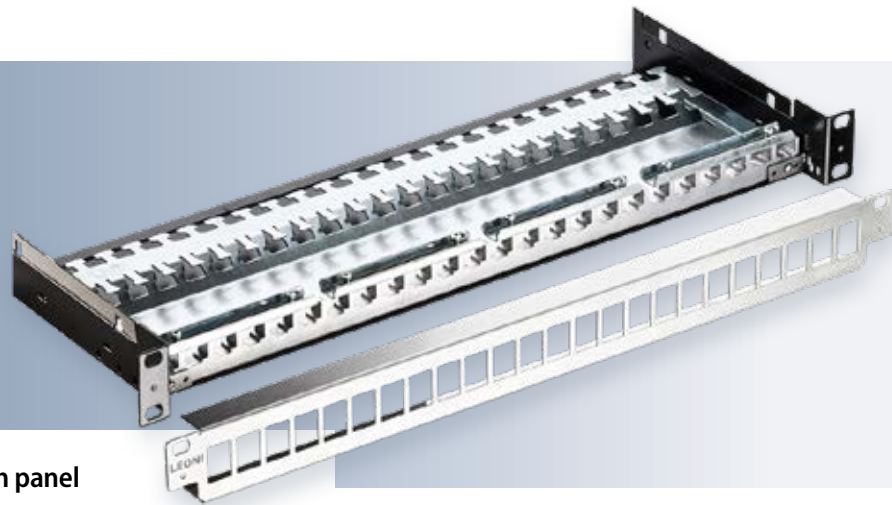

MegaLine® 24 EM patch panel

Description

Modular 3-part universal patch panel for 24 MegaLine® Connect100 ports. Modules can be hot-swapped.

Patch panel set

consisting of base carrier, cable socket carrier, stainless steel front panel

Base support

- for holding a cable socket carrier
- is installed in advance in the cabinet or rack

Labelling

Using labelling strip made of aluminium, self-adhesive (must be ordered separately, see table)

Cable socket carrier

- Unit of cable plugs
- Mounted outside the cabinet and/or base carrier
- is inserted into the base carrier on the rear side
- Fastening by means of slide lock
- Potential equalisation with two threaded bolts M5 and/or two earth lugs

Stainless steel front cover (depending on version)

Cut-outs for 24 MegaLine® Connect100 jack modules

Construction

Strain relief	via cable ties
Earthing	see page 119
Cable entrance	over the entire width of the cable management rail
Dimension	44 mm x 483 mm x 163 mm (H x B x D)

Accessory (has to be ordered in addition)

Labelling strips

Article	Capacity	Ports	Order no.
MegaLine® Connect100 patch panel 24 EM	for installation of 24 jack modules: RJ45 Cat. 6 _a	for 24 MegaLine® Connect100 ports	LKD 9A90 2203 0000
Labelling strips			LKD 9A67 0024 0000

MegaLine® Connect100 Patch panel 19"

unequipped



MegaLine® Connect100 patch panel 19" 24 Port

Description

The patch panel can be fitted with max. 24 MegaLine® Connect100 jack modules. Compatible with the jack modules MegaLine® Connect45 (VK format).

Construction

Housing	Sheet steel
Colour	Light grey, RAL 7035 Jet black, RAL 9005
Labelling	1–24
Capacity	max. 24 Jack modules: 4K7A / 8C7A / RJ45
Strain relief	via cable ties
Earthing	see page 119
Cable entrance	over the entire width of the cable management rail
Construction	24 ports

Dimension

19" / 1 RU
100 mm installation depth

Article	Colour	Order no.
MegaLine® Connect100 patch panel 19" / 24-port (1 pc.)	● Light grey RAL 7035	LKD 9A90 2201 0000
	● Jet black RAL 9005	LKD 9A90 2202 0000

MegaLine® Connect100 DIN rail housing

dual, with DIN rail clip



MegaLine® Connect100 rail housing dual

Description

With dual rail clip to take max. 2 MegaLine® Connect100 jack modules. Compatible with the jack modules MegaLine® Connect45 (VK format).

The housing is mounted by snapping it onto the existing DIN rails. The metal housing is particularly suitable for use in industrial environments.

Construction

Material	Sheet steel, powder coated
Colour	Light grey, RAL 7035
Capacity	max. 2 MegaLine® Connect100 jack modules

Dimension

85 mm x 35 mm x 95 mm (H x B x D)

Article	Order no.
MegaLine® Connect100 DIN rail housing, dual (1 pc.)	LKD 9A46 0097 0000

MegaLine® accessory and cable assembly tools



MegaLine® Connect100 blind cover

Description

For wall outlets, in white or black.

Article	PU	Order no.
MegaLine® Connect100 blind cover Pure white, RAL 9010	50 pc.	LKD 9A46 0034 0000
MegaLine® Connect100 blind cover Black, RAL 9005		LKD 9A46 0083 0000



MegaLine® Connect100 dust cap

Description

For colour coding The transparent design also enables the identification of the connector face while closed.

Article	PU	Colour	for jack modules RJ45 / 8C7A	for jack modules 4K7A
MegaLine® Connect100 Dust protective- flap	50 pc.	● Red	LKD 9A90 4002 0000	LKD 9A90 4042 0000
		● Green	LKD 9A90 4003 0000	LKD 9A90 4043 0000
		● Blue	LKD 9A90 4004 0000	LKD 9A90 4044 0000
		● Yellow	LKD 9A90 4005 0000	LKD 9A90 4045 0000
		○ White	LKD 9A90 4006 0000	LKD 9A90 4046 0000



MegaLine® side cutter

Description

For simple and secure shortening of wire pairs.

Article	PU	Order no.
MegaLine® side cutter	1 pc.	LKD 9ZE3 0012 0000



MegaLine® Connect100 crimping tool

Description

For easy assembly of jack modules with the plug and wire manager.

Article	PU	Order no.
MegaLine® Connect100 crimping tool	1 pc.	LKD 9A90 4007 0000



MegaLine® stripping tool

Description

Quick and simple stripping of copper data cables (esp. S/FTP).
For removing the outer sheath as well as the PiMF foil.

Article	PU	Order no.
MegaLine® stripping tool	1 pc.	LKD 9AW1 6045 0000



MegaLine® Connect100 assembly aid

Description

For easy adjustment and cutting to length of the conductors
assembling the MegaLine® Connect100 cable plugs or interface
plugs (cross design).

Article	PU	Order no.
MegaLine® Connect100 assembly aid	10 pc.	LKD 9A90 4001 0000
MegaLine® Connect100 assembly tool cross		LKD 9A90 4009 0000



MegaLine® Connect100 test adapter

Description

For direct acceptance measurement of Class F_A / Channel Class II
on the cable plug (≥ 1000 insertion cycles). It is not necessary to
use a 8C7A/4K7A jack module or an interface module.

Article	PU	Order no.
MegaLine® Connect100 test adapter	2 pc.	LKD 9A90 4020 0000
MegaLine® Connect100 replacement kit (for an additional 1000 insertion cycles)	2 pc.	LKD 9A90 4022 0000

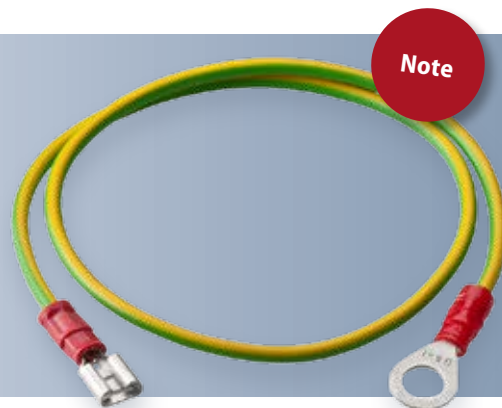















Example of an earthing cable

Description

In order to create a conductive connection of our 19" patch
panels in cabinets for IT facilities as well as data wall outlets,
we recommend using suitable equipotential bonding conduc-
tors according to EN 50310.

MegaLine® Connect45
MegaLine® Connect45 Pro
Cu connectivity



MegaLine® Connect45 – the cabling system from 1 – 10 Gbit/s			page
	MegaLine® Connect45 – the modular connection technology	Connection technology can be this simple	122
	LEO and LED function	The "pathfinder features"	123
	Connection components	RJ45 plug and LinkExtender	124
	Installation options		125
	Two technologies – one solution ... from 1 – 10 Gbit/s	System overview	126
	Cable plug	<ul style="list-style-type: none"> • Cable plug AWG24-22 • Cable plug AWG27-26 	128
	Jack modules in VK format	<ul style="list-style-type: none"> • Jack module BM ISO/IEC Cat. 6_A • Jack module LEO BM ISO/IEC Cat. 6_A 	129
	Jack modules in Keystone® format	<ul style="list-style-type: none"> • Jack module BM ISO/IEC Cat. 6_A • Jack module LEO BM ISO/IEC Cat. 6_A • Jack module LEO BM ISO/IEC angled Cat. 6_A • Jack module BM UTP Cat. 6 	130
	Jack modules in ELine format	<ul style="list-style-type: none"> • Jack module ELine BM ISO/IEC Cat. 6_A • LinkExtender 	132
	RJ45 plug		133
	Connect45 patch panels 19"	<ul style="list-style-type: none"> • Keystone® format • ELine format 	134
	Connect100 patch panel 19"	VK format	135
	Connect45 wall outlets for Keystone® jack modules	<ul style="list-style-type: none"> • 50 x 50 • 45 x 45 	136
	Connect100 wall outlets for VK jack modules	<ul style="list-style-type: none"> • 50 x 50 • 45 x 45 	137
	Accessories & tools	<ul style="list-style-type: none"> • LEO detector • Protecting cap • Assembly tool • Unlocking tool 	138
MegaLine® Connect45 Pro – the cabling system up to 10 Gbit/s			page
	The cabling system up to 10 Gbit/s	System overview	139
	Jack modules in Keystone® format	<ul style="list-style-type: none"> • Jack module BM ISO/IEC Cat. 6_A • 90° adapter 	140
	Connect45 patch panel 19"	• Keystone format	141
	Connect45 Pro wall outlets for Keystone® jack modules	• 50 x 50	141
	Office		
	DataCenter		

MegaLine® Connect45 – the modular connection technology

Connection technology can be this simple

The basic kit >

MegaLine® data cable Cat. 6_A + Cable plug

Supplementation is by simply adding on the desired connection component

Connection components >

Simply add on – finished!

**Very short
assembly time ·
Outstanding electrical
performance ·
Future-proof**
and all this with
maximum flexibility.



Jack module
Cat. 6_A (page 131)



RJ45 plug
Cat. 6_A (page 133)



LinkExtender
(page 132)

Benefits >>

> Assembly without additional cable ties

> High level of safety

Visual check by means of a transparent cable plug

> Components with LEO function

> LED patch cord

> Power over Ethernet (PoE)

> Different formats for maximum packing density

The cable plug – the system basis

RJ45 jack modules of Category 6_A (IEC 60603-7-51) are used here.

The new Keystone® jack module has been modified in such a way that it is not necessary to attach a separate cable tie. The transparent cable plug facilitates cable pre-fabrication, thereby allowing visual check of the correct colour assignment of the individual wire pairs.

Using the appropriate stripper it is possible to crimp the cores in the IDC insulation displacement connectors and also remove excess cores so they are flush – this is how to ensure the correct connection!



Ultra-simple installation – crimp and trim wires in a single work step

LEO and LED function

The "pathfinder features"



The jack modules are optionally available with LEO functionality

> **LEO** = Light **E**mitting **O**utlet

With the aid of a transmitter connected to one end of an installed link, the opposite end can be easily identified by means of a red LED display contained within the jack module. This feature is particularly useful in environments with a high packing density, enabling the corresponding modules to be located quickly and reliably. The module is easy to open using the unlocking tool.

With a single click, it is thus possible to expand the existing cabling system by adding on a new module, e.g. the LEO function.

Via the LEO detector the light signal is fed into the link ...



Shielded technology

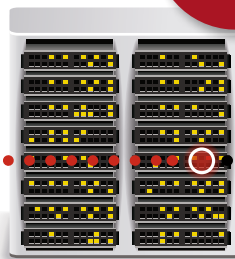

... and the appropriate jack module on the other side lights up.



RJ45 patch cord with LED function

Category 6 or Category 6_A patch cords complete the cabling link.

In complex patch environments inside wiring cabinets, you also have a clear overview of the patch cord sides that belong together thanks to the integrated red LEDs.

The connector can either be lit up permanently or flash at two different frequencies.

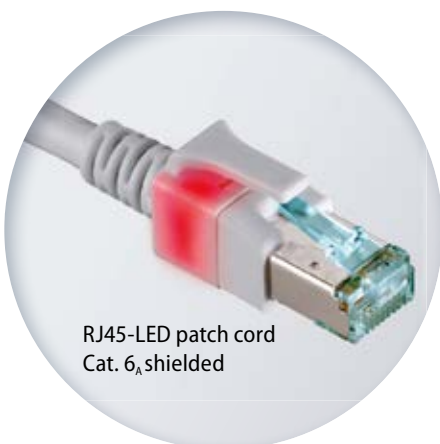

RJ45-LED patch cord
Cat. 6_A shielded

Connection components

RJ45 plug and LinkExtender

RJ45 plug (Category 6_A)

Using the RJ45 plug, it is possible to use the same MegaLine® Connect45 cable plug very simply to realise Consolidation Point applications or also PoE applications (Power over Ethernet), e.g. connect IP cameras or access points.

In so doing, the existing requirements of IEEE802.3 af/at are supported (15W/25W) as well as future applications up to 100 W. The RJ45 plug can be used in conjunction with both horizontal and flex cables. When using PoE end devices such as access points, components such as additional wall boxes and patch cords are no longer required. The connection is made directly via the data cable.

LinkExtender

The LinkExtender allows you to extend existing Class E_A cabling links quickly and efficiently without loss of performance.

Use the unlocking tool to open the existing jack module, replace it with a LinkExtender and insert a pre-fabricated additional cabling link in the required length – the job is done!



RJ45 plug
Cat. 6_A (page 133)

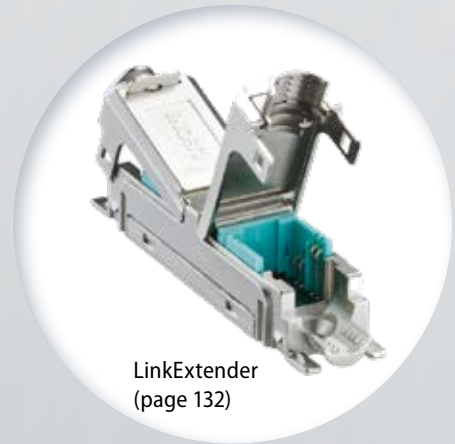

LinkExtender
(page 132)

The LinkExtender can be used for easy extension of Class E_A cabling links >

Extend existing
cable connections ...



... by opening the jack module with
the unlocking tool ...



... and remove the jack module
from the cable plug.



Instead of the jack module, add on the
LinkExtender ...



... and extending accordingly on the
second side.



Finally, use two
cable ties to securely close the covers.



Installation options

DCLink – the real Plug&Play solution

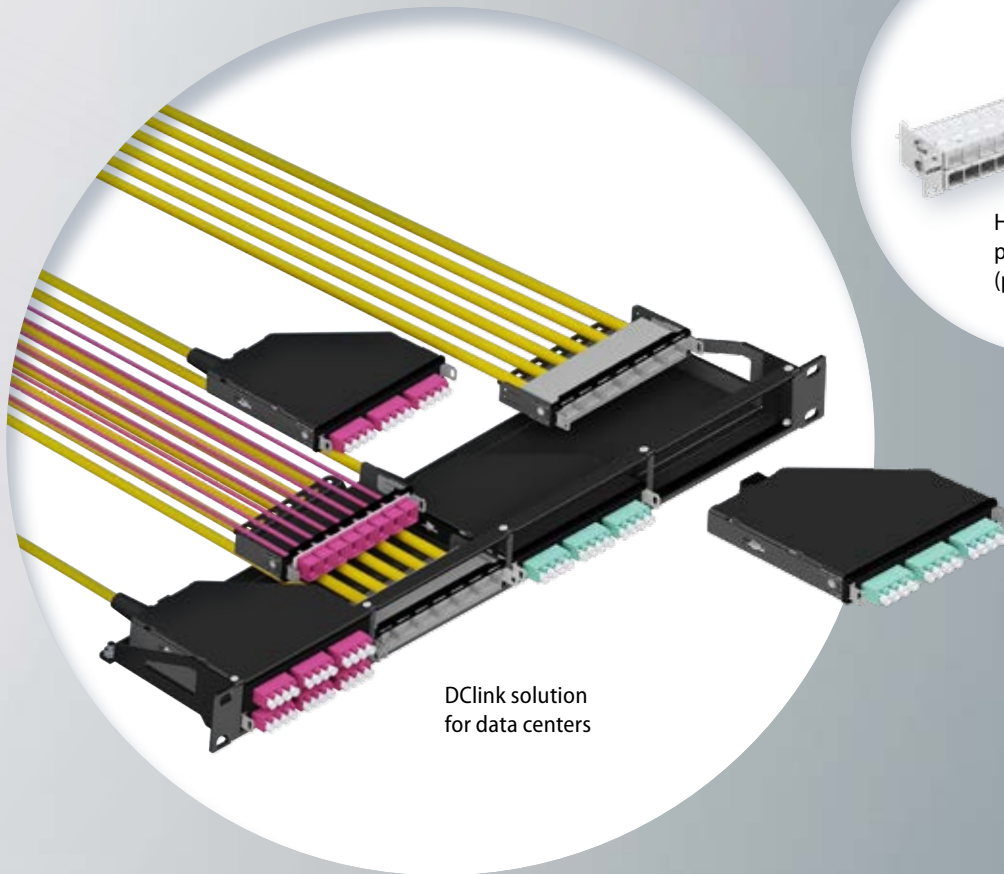

DCLink solution
for data centers



HighDensity
patch panel 48Port/1RU
(page 134)

There are a wide range of installation options available for the jack modules. These range from design-capable wall outlets and Consolidation Point housings (also for DIN rail assembly) through to underfloor solutions and various patch panels.

In combination with the MegaLine® Connect45 module (in ELine format) it is possible to realise high-density solutions of up to 48 ports on one rack unit.

When using DCLink, the universal LEONI solution for data centers, copper can be flexibly combined with FO inside a rack unit, too.

Summary

No matter how your network is structured, you now have the full range of options available to you.

MegaLine® Connect45 – the cabling system from 1 – 10 Gbit/s when it comes down to very short installation times, maximum flexibility and maximum performance.

Two technologies – one solution ... from 1 – 10 Gbit/s

System overview

MegaLine® flex cable

MegaLine® horizontal cable

MegaLine® Connect45 pre-assembled trunk

MegaLine® Cable

Cable plug page 128

MegaLine® Connect45 RJ45 jack module Cat. 6 page 131

MegaLine® Connect45



1 Gbit/s

1 – 10 Gbit/s

for data rates up to ...

MegaLine® flex cable

MegaLine® horizontal cable

MegaLine® Connect45 pre-assembled trunk page 158

MegaLine® Cable

Cable plug page 128

MegaLine® Connect45 RJ45 jack module Cat. 6 page 130

MegaLine® Connect45



Unshielded cabling system Cat. 6 / Class E



Wall outlets
Page 136/137



VarioLine® UF
Underfloor systems
page 169



VarioLine® CP
Consolidation Point housing
page 166



MegaLine® Connect45
24-port patch panel 19" / 1 RU
straight
page 134

MegaLine® Connect45
24-port patch panel 19" / 1 RU
angled

Shielded cabling system Cat. 6_A / Class E_A

unshielded
1 Gbit/s



MegaLine®
RJ45 patch cord Cat.6
Unshielded
page 145

1 Gbit/s

1 – 10 Gbit/s

shielded
10 Gbit/s



MegaLine® RJ45
LED patch cord Cat. 6_A
shielded
page 149

MegaLine®
RJ45 patch cord Cat. 6_A, shielded
page 147

MegaLine® Connect45 cable plug

AWG24-22 / AWG27-26

Fig. 1
Cable plug AWG24-22



Fig. 2
Cable plug AWG27-26



MegaLine® Connect45-cable plug AWG24-22 MegaLine® Connect45-cable plug AWG27-26

Description

The MegaLine® Connect45 cable plug has a cutting/clamping connection and is crimped together with the installation cable. It is the interface to the individually interchangeable MegaLine® Connect45 jack module.

This means that generic transmission links far exceeding the requirements for Class E_A can be achieved, depending on the relevant jack module.

The jack module can also be changed retroactively without any additional installation effort.

- Simple and fast assembly

Construction

Material	Plastic
Wiring	4-pairs via IDC contacts according to EIA/TIA 568A/B
Core type	AWG 24 – 22 solid and flex or AWG 27 – 26 solid and flex

Accessories see page 118, 138

MegaLine® Connect45 protecting cap

The fitted cable plug can be protected against environmental influences by the protective cap.



Fig.	Article	Core type	Colour	Order no.
1	MegaLine® Connect45 cable plug AWG24-22 (25 pc.)	AWG 24 – 22 solid and flex	● Plastic, yellow	LKD 9A50 4010 0000
2	MegaLine® Connect45 cable plug AWG27-26 (25 pc.)	AWG 27 – 26 solid and flex	○ Plastic, transparent	LKD 9A50 4011 0000

MegaLine® Connect45 jack modules in VK format

Category 6_A

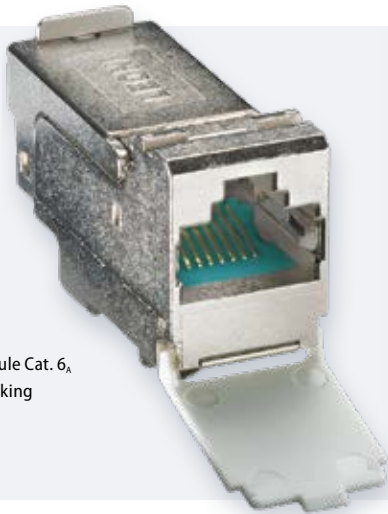

Jack module Cat. 6_A
Aqua marking

MegaLine® Connect45 BM ISO/IEC

Description

For transmitting analogue and digital voice, image and data signals. The performance features are the same as for Cat. 6_A (ISO/IEC) up to 500 MHz. Class E_A requirements in terms of channel and permanent links according to ISO/IEC 11801 Amd. 1/2 are met from 1 m (Cat. 6_A).

The length specifications relate to the 2-connector model.

Construction

Material	Full metal; die-cast zinc, nickel-plated
Wiring	4 pairs via cable plug
Connection	RJ45 jack, with integrated dust cap compatible with MegaLine® Connect100

Standards

- ISO/IEC 11801
- EN 50173-1
- IEC 60603-7-51

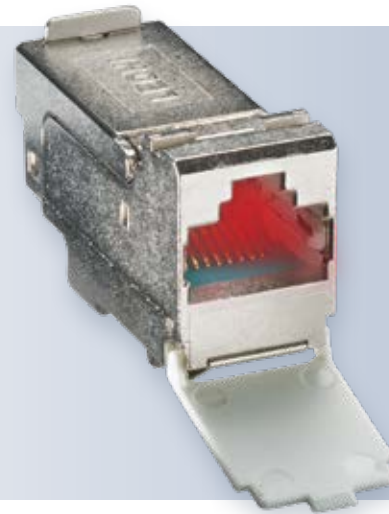

MegaLine® Connect45 LEO BM ISO/IEC

Description

For transmitting analogue and digital voice, image and data signals. The performance features are the same as for Cat. 6_A (ISO/IEC) up to 500 MHz. Class E_A requirements in terms of channel and permanent links according to ISO/IEC 11801 Amd. 1/2 are met from 1 m (Cat. 6_A).

The length specifications relate to the 2-connector model.

Construction

Material	Full metal; die-cast zinc, nickel-plated
Wiring	4-pairs via cable plug
Connection	RJ45 jack, with integrated dust cap compatible with MegaLine® Connect100

Standards

- ISO/IEC 11801
- EN 50173-1
- IEC 60603-7-51

LEO function

LEO =	Patch panels with LEO function
Light Emitting Outlet	enable simple link tracking during installation.
Light detection	≤ 200 m
Signal feed	Via the LEO detector For description, see page 161

Article	PU	Marking	Order no.
MegaLine® Connect45 BM ISO/IEC	24 pc.	Aqua	LKD 9A50 2010 0024

Article	PU	Marking	Order no.
MegaLine® Connect45 LEO BM ISO/IEC	1 pc.	Aqua	LKD 9A50 2011 0000

MegaLine® Connect45 jack modules in Keystone® format

Category 6_A



Jack module Cat. 6_A
Aqua marking



Jack module
Cat. 6_A with
LEO function
Aqua marking

MegaLine® Connect45 BM ISO/IEC

Description

For transmitting analogue and digital voice, image and data signals. The performance features are the same as for Cat. 6_A (ISO/IEC) up to 500 MHz. Class E_A requirements in terms of channel and permanent links according to ISO/IEC 11801 Amd. 1/2 are met from 1 m (Cat. 6_A).

The length specifications relate to the 2-connector model.

Construction

Material	Full metal; die-cast zinc, nickel-plated
Wiring	4 pairs via cable plug
Connection	RJ45 jack, with integrated dust cap

Standards

- ISO/IEC 11801
- EN 50173-1
- IEC 60603-7-51

Article	PU	Marking	Order no.
MegaLine® Connect45 BM ISO/IEC	24 pc.	Aqua	LKD 9A50 1010 0024

MegaLine® Connect45 LEO BM ISO/IEC

Description

For transmitting analogue and digital voice, image and data signals. The performance features are the same as for Cat. 6_A (ISO/IEC) up to 500 MHz. Class E_A requirements in terms of channel and permanent links according to ISO/IEC 11801 Amd. 1/2 are met from 1 m (Cat. 6_A).

The length specifications relate to the 2-connector model.

Construction

Material	Full metal; die-cast zinc, nickel-plated
Wiring	4 pairs via cable plug
Connection	RJ45 jack, with integrated dust cap

Standards

- ISO/IEC 11801
- EN 50173-1
- IEC 60603-7-51

LEO function

LEO =	Patch panels with LEO function
Light Emitting Outlet	allow simple link tracking during installation.
Light detection	≤ 200 m
Signal feed	Via the LEO detector
	For description, see page 161

Article	PU	Marking	Order no.
MegaLine® Connect45 LEO BM ISO/IEC	1 pc.	Aqua	LKD 9A50 1011 0000

Jack module Cat. 6_A
Aqua marking



MegaLine® Connect45 BM ISO/IEC angled

Description

For transmitting analogue and digital voice, image and data signals. The performance features are the same as for Cat. 6_A (ISO/IEC) up to 500 MHz. Class E_A requirements in terms of channel and permanent links according to ISO/IEC 11801 Amd. 1/2 are met from 1 m (Cat. 6_A).

The length specifications relate to the 2-connector model.

Construction

Material	Full metal; die-cast zinc, nickel-plated
Wiring	4 pairs via cable plug
Connection	RJ45 jack, with integrated dust cap

Standards

- ISO/IEC 11801
- EN 50173-1
- IEC 60603-7-51

Article	Marking	Order no.
MegaLine® Connect45 BM ISO/IEC angled (1 pc.)	Aqua	LKD 9A50 1060 0000

Jack module Cat. 6, black



MegaLine® Connect45 BM UTP

Description

For transmitting analogue and digital voice, image and data signals. The performance features are the same as for Cat. 6 up to 250 MHz. Class E requirements for channel and permanent links are met according to ISO/IEC 11801 Amd. 1/2

Construction

Material	Plastic
Wiring	4 pairs via cable plug
Connection	RJ45 jack

Standards

- ISO/IEC 11801
- EN 50173-1
- IEC 60603-7-51

Article	Marking	Order no.
MegaLine® Connect45 BM UTP (24 pc.)	Black	LKD 9A50 1050 0000

MegaLine® Connect45 jack modules in ELine format

Category 6_A

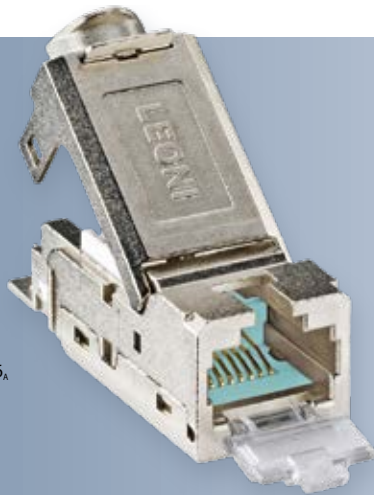

Jack module Cat. 6_A
Aqua marking

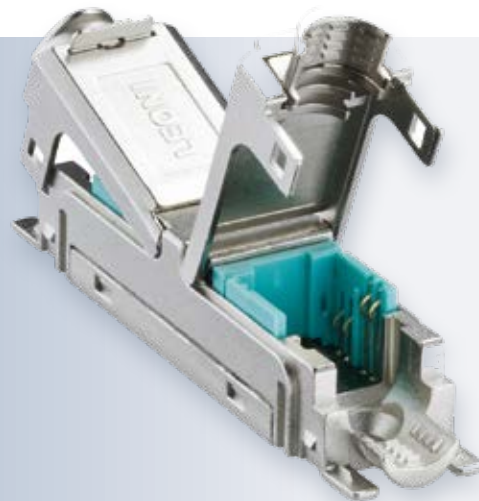

MegaLine® Connect45 BM ELine ISO/IEC

Description

For transmitting analogue and digital voice, image and data signals. The performance features are the same as for Cat. 6_A (ISO/IEC) up to 500 MHz. Class E_A requirements in terms of channel and permanent links according to ISO/IEC 11801 Amd. 1/2 are met from 1 m (Cat. 6_A).

The length specifications relate to the 2-connector model.

Construction

Material	Full metal; die-cast zinc, nickel-plated
Wiring	4 pairs via cable plug
Connection	RJ45 jack, with integrated dust cap

Standards

- ISO/IEC 11801
- EN 50173-1
- IEC 60603-7-51

Article	Marking	Order no.
MegaLine® Connect45 BM ELine ISO/IEC	Aqua	LKD 9A50 5010 0000

MegaLine® Connect45 LinkExtender

Description

For extending an existing cable infrastructure to max. 90 m without transmission loss, based on the MegaLine® Connect45 system.

Due to its small size, the Extender can also be integrated into the cable duct retroactively. The link performance of Class E_A to be achieved also enables the transmission of 10 Gigabit Ethernet via an extended link.

Construction

Material	Full metal; die-cast zinc, nickel-plated
Wiring	2x 4 pairs via cable plug

Standards

- ISO/IEC 11801 ■ EN 50173-1

Article	Marking	Order no.
MegaLine® Connect45 LinkExtender	Aqua	LKD 9A50 0010 0000

MegaLine® Connect45 RJ45 plug

Category 6_A



MegaLine® Connect45 RJ45 Cat. 6_A

Description

By using the same MegaLine® Connect45 cable plug, it is possible to implement Consolidation Point and/or PoE applications very simply with the help of the RJ45 plug. Depending on the cable plug used, a horizontal or flex cable can be selected.

The transmission properties are those of Class E_A according to ISO/IEC 11801/EN 50173-1. 10 GbE is supported.

Construction

Material	Full metal; die-cast zinc, nickel-plated
Wiring	4 pairs via cable plug
Connection	RJ45 plug

Mechanical characteristics

Insertion cycles	≥ 750 (on RJ45 side)
Contact area	50 μ gold plating
Contacts	AWG 26/-22

Note **Crimping only using the MC45 assembly tool (see page 138)**
Cable plug has to be ordered separately (page 128)

Cable diameter	5 – 9 mm
----------------	----------

Environmental requirement

Connection class	IP20
Temperature range	–40 °C to +70 °C

Electrical characteristics

Suitable for PoE+ according to IEEE802.3at

Article	PU	Order no.
MegaLine® Connect45 RJ45 plug Cat.6 _A (ISO/IEC)	1 pc.	LKD 9A50 0020 0000

MegaLine® Connect45 patch panels 19"

in Keystone® or ELine format – various versions

Patch panel 19"
in Keystone® format

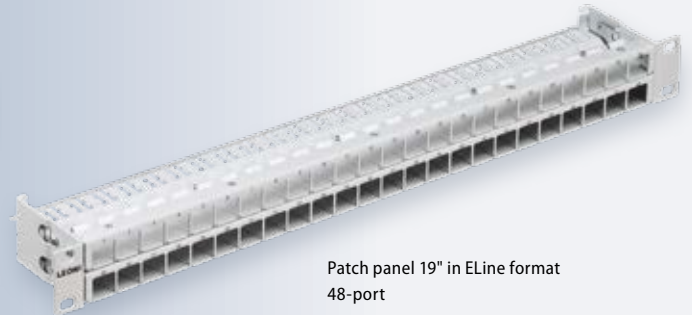
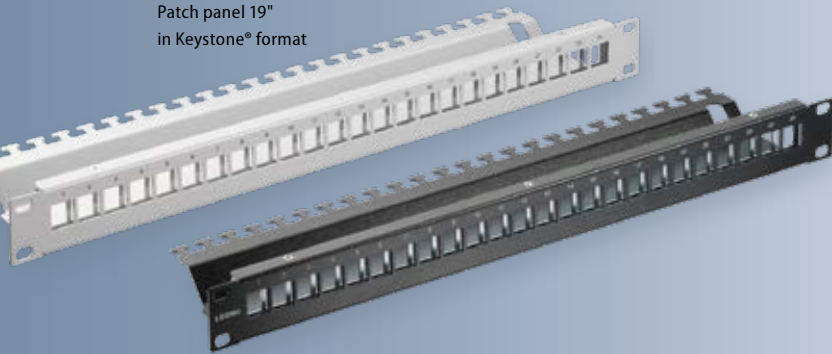

Patch panel 19" in ELine format
48-port

MegaLine® Connect45 patch panel 19" Keystone MegaLine® Connect45 patch panel 19" ELine

Description

The patch panel can be fitted with up to 24 or 48 jack modules.

Refer to the order table below for versions and formats available.

Construction

Housing	Full metal
Colour	Light grey, RAL 7035 Jet black, RAL 9005
Capacity	See order table below
Strain relief	via cable ties
Earthing	see page 119
Cable entrance	over the entire width of the cable management rail

Dimension

19" / 1 RU or 0.5 RU, 110 mm installation depth

Article	Format	Capacity max. / RU	Labelling	Colour	Order no.	Colour	Order no.
MegaLine® Connect45 Patch panel 19"	Keystone	24 jack modules / 1 RU	1-24	● Light grey RAL 7035	LKD 9A50 1200 0000	● Jet black RAL 9005	LKD 9A50 1201 0000
					LKD 9A50 5200 0000		LKD 9A50 5201 0000
MegaLine® Connect45 Patch panel 19" ELine	ELine	24 jack modules / 1 RU	1-24		LKD 9A50 5206 0000		LKD 9A50 5207 0000
	ELine	48 jack modules / 1 RU	1-48				

MegaLine® Connect100 patch panel 19"

in VK format



MegaLine® Connect100 patch panel 19" VK format

Description

The patch panel can be fitted with max. 24 MegaLine® Connect45 jack modules in VK format.

Compatible with the MegaLine® Connect45 jack modules (VK format).

Construction

Housing	Sheet steel
Colour	Light grey, RAL 7035 Jet black, RAL 9005
Labelling	1–24
Capacity	max. 24 jack modules in VK format
Strain relief	via cable ties
Earthing	see page 119
Cable entrance	over the entire width of the cable management rail
Construction	24 ports

Dimension

19" / 1 RU

100 mm installation depth

Article	Colour	Order no.
MegaLine® Connect100 patch panel 19" / 24-port (1 pc.)	● Light grey RAL 7035	LKD 9A90 2201 0000
	● Jet black RAL 9005	LKD 9A90 2202 0000

MegaLine® Connect45 wall outlets

for Keystone® jack modules



Fig. 1
Wall outlet
50 x 50 / 1-fold



Fig. 2
Wall outlet
50 x 50 / dual



Fig. 3
Wall outlet
50 x 50 / 3-fold



Fig. 4
Wall outlet
45 x 45 / 1-fold



Fig. 5
Wall outlet
45 x 45 / dual

MegaLine® Connect45 Wall outlet Keystone 50 x 50

German design





Wall outlets for fitting with MegaLine® Connect45 jack modules in Keystone® format.

Construction

Housing body	Full metal; die-cast zinc, nickel-plated
Colours	Pure white, RAL 9010
Labelling	via labelling field

Dimension

50 mm x 50 mm x 30 mm (H x B x D),
downward inclination 30°

Fig.	Article	Order no.
1	 MegaLine® Connect45 wall outlet Keystone 50 x 50 / 1-fold	LKD 9A50 1100 0000
2	 MegaLine® Connect45 wall outlet Keystone 50 x 50 / dual	LKD 9A50 1101 0000
3	 MegaLine® Connect45 wall outlet Keystone 50 x 50 / 3-fold	LKD 9A50 1102 0000
-	 40 mm surface-mounted housing	LKD 9A46 0086 0000
-	 Spacer frame for 1-fold surface-mounted housing, 10 mm	LKD 9A46 0088 0000

MegaLine® Connect45 Wall outlet Keystone 45 x 45

French design



Wall outlets for fitting with MegaLine® Connect45 jack modules in Keystone® format.

Construction

Housing body	Plastic
Colours	Pure white, RAL 9010
Labelling	via labelling field

Dimension

45 mm x 45 mm x 42 mm (H x B x D),
downward inclination 30°

Fig.	Article	Order no.
4	 MegaLine® Connect45 wall outlet Keystone 45 x 45 / 1-fold	LKD 9A50 1104 0000
5	 MegaLine® Connect45 wall outlet Keystone 45 x 45 / dual	LKD 9A50 1103 0000
-	 VarioLine® cover frame 45 x 45 (8 pc.)	LKD 9ZE8 0013 0000

MegaLine® Connect100 wall outlets

for MegaLine® Connect45 and MegaLine® Connect100 jack modules in VK format



Fig. 1
50 x 50 / 1-fold
wall outlet



Fig. 2
50 x 50 / dual
wall outlet

Fig. 3
50 x 50 / 3-fold
wall outlet



Fig. 4
Wall outlet
45 x 45 / 1-fold
(similar to fig.)



Fig. 5
Wall outlet
45 x 45 / dual (similar to figure)

MegaLine® Connect100 50 x 50 wall outlets

German design

Wall outlets for installation in commonly available 50 x 50 mm cover frame. For fitting with MegaLine® Connect45 or MegaLine® Connect100 jack modules in VK format.

Housing

Housing body	Full metal; die-cast zinc, nickel-plated
Colours	Pure white, RAL 9010
Labelling	via labelling field

Installation dimensions

50 mm x 50 mm (H x W), downward inclination of 30°

Accessories (optional)

MegaLine® Connect100 1 and 2-fold cover frame
40 mm surface-mounted housing incl. 1-fold flush-mounted cover frame
Spacer frame for 1-fold surface-mounted housing, 10 mm

MegaLine® Connect100 45 x 45 wall outlets

French design

wall outlets fitting with MegaLine® Connect45 or MegaLine® Connect100 jack modules in VK format.

Housing











Housing body	Plastic
Colours	Pure white, RAL 9010
Labelling	via labelling field

Installation dimensions

45 mm x 45 mm x 42 mm (H x B x D), downward inclination 30°

Accessories (optional)

VarioLine® cover frame

Fig.	Article	Colour	Order no.
1	 MegaLine® Connect100 wall outlet 50 x 50 / 1-fold (1 pc.)	○ Pure white, RAL 9010	LKD 9A46 0107 0000
2	 MegaLine® Connect100 wall outlet 50 x 50 / dual (1 pc.)		LKD 9A46 0108 0000
3	 MegaLine® Connect100 wall outlet 50 x 50 / 3-fold (1 pc.)		LKD 9A46 0109 0000
-	 Flush-mounted cover frame 1-fold (1 pc.)	○ Pure white, RAL 9010	LKD 9A41 0003 0000
-	 Flush-mounted cover frame, 2-fold (1 pc.)		LKD 9A41 0005 0000
-	 Surface-mounted housing 40 mm incl. UP-cover frame 1-fold (1 pc.)		LKD 9A46 0086 0000
-	 Spacer frame for surface-mounted housing 1-fold 10 mm (1 pc.)		LKD 9A46 0088 0000
1	 MegaLine® Connect100 wall outlet 45 x 45 / 1-fold	○ Pure white, RAL 9010	LKD 9A90 1101 0000
2	 MegaLine® Connect100 wall outlet 45 x 45 / dual		LKD 9A90 1100 0000
3	 VarioLine® cover frame 45 x 45 (8)		LKD 9ZE8 0013 0000

Accessories & tools

for MegaLine® Connect45



MegaLine® Connect45 LEO detector

Accessories

Detector for feeding in the voltage when using a Connect45 jack module with LEO function.

Housing	Full metal
Contacts	RJ45 plug
Supply	1x battery 23AE/12V

Article	Order no.
MegaLine® Connect45 LEO detector	LKD 9A50 4005 0000



The cable assembled with the Connect45 Cable plug is simply inserted into the protecting cap and locked

MegaLine® Connect45 protecting cap

Accessories

For safe and convenient protection of pre-assembled trunk cables supplied with MegaLine® Connect45 cable connectors.

Article	Order no.
MegaLine® Connect45 protecting cap (25 pc.)	LKD 9A50 4003 0000



MegaLine® Connect45 assembly tool

Accessories

It takes just a single step to press the contacts of the cable connector together and remove the excess wires.

Article	Order no.
MegaLine® Connect45 assembly tool	LKD 9A50 4001 0000

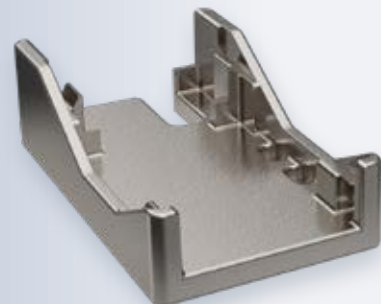

MegaLine® Connect45 unlocking tool

Accessories

For quick and easy opening of the MegaLine® Connect45 jack module.

Article	Order no.
MegaLine® Connect45 unlocking tool	LKD 9A50 4000 0000

MegaLine® Connect45 Pro – the cabling system up to 10 Gbit/s

System overview

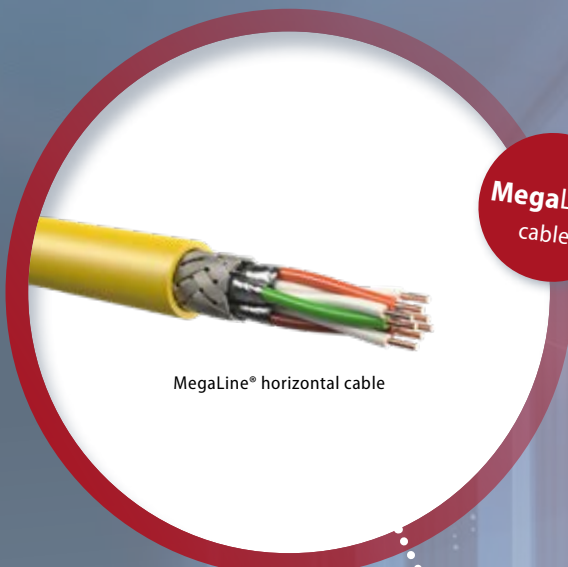

MegaLine® horizontal cable

MegaLine®
cables



MegaLine® Connect45 Pro
Jack modules in Keystone® format
page 140

MegaLine®
Connect45 Pro



Wall outlets
page 141

VarioLine® UF
Underfloor systems
page 169

VarioLine® CP
Consolidation Point
housing
page 166

MegaLine® Connect45
Patch panels 19"
for Keystone® format
page 141

MegaLine®
copper systems
technology

for data rates up to...

10 Gbit/s

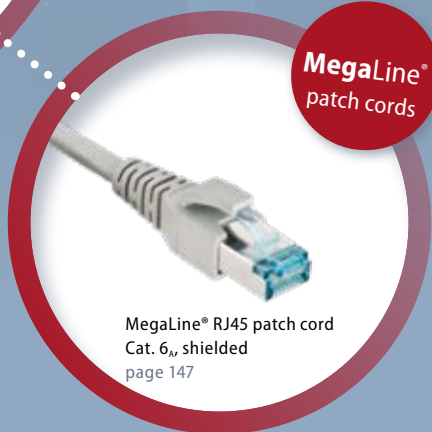

MegaLine® RJ45 patch cord
Cat. 6, shielded
page 147

MegaLine®
patch cords

MegaLine® Connect45 Pro jack modules in Keystone® format

Category 6_A



MegaLine® Connect45 Pro BM ISO/IEC

Description

For transmitting analogue and digital voice, image and data signals. The performance features are the same as for Cat. 6_A (ISO/IEC) up to 500 MHz. Class E_A requirements in terms of channel and permanent links according to ISO/IEC11801 Amd. 1/2 from 1 metre are met.

The length specifications relate to the 2-connector model.

Construction

Material	Full metal; die-cast zinc, nickel-plated
Wiring	4 pairs via cable plug
Connection	RJ45 jack

Standards

- ISO/IEC 11801
- EN 50173-1
- IEC 60603-7-51

Article	PU	Marking	Order no.
MegaLine® Connect45 Pro BM ISO/IEC	50 pc.	White	LKD 9ZQ0 1000 0000

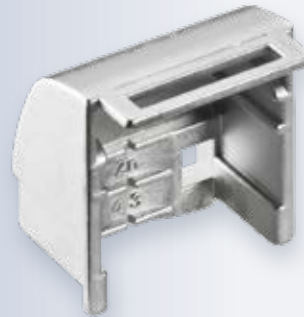

MegaLine® Connect45 Pro 90° adapter

Description

Simply add on to the MegaLine® Connect45 jack. This enables installation where space is limited (e.g. wall channel) at a 90° angle.

Construction

Material	Full metal; die-cast zinc, nickel-plated
----------	--

Article	PU	Order no.
MegaLine® Connect45 Pro 90° adapter	20 pc.	LKD 9ZQ0 1001 0000

MegaLine® Connect45 patch panels 19"

for Keystone® format

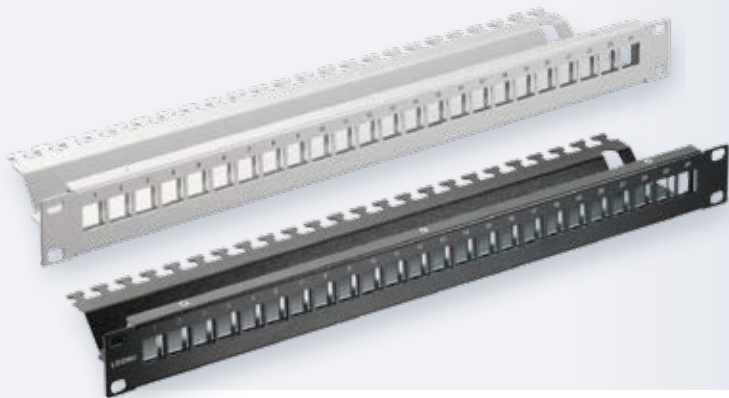

**MegaLine® Connect45 patch panel 19"
Keystone**

Description

The patch panel can be fitted with max. 24 jack modules in Keystone format.

Construction

Housing	Full metal
Colour	Light grey, RAL 7035, Jet black, RAL 9005
Capacity	max. 24 Jack modules in Keystone® format
Strain relief	via cable ties
Earthing	see page 119
Cable entrance	over the entire width of the cable management rail

Dimension

19" / 1 RU, 110 mm installation depth

Article	Colour	Order no.
MegaLine® Connect45 Patch panel 19" Keystone (1 pc.)	● Light grey RAL 7035	LKD 9A50 1200 0000
	● Jet black RAL 9005	LKD 9A50 1201 0000

MegaLine® Connect45 Pro wall outlets

for Keystone® jack modules



**MegaLine® Connect45 Pro
Keystone 50 x 50 wall outlet**

German design





Wall outlets for fitting with MegaLine® Connect45 Pro jack modules in Keystone format.

Construction

Housing body	Full metal; die-cast zinc, nickel-plated
Colours	Pure white, RAL 9010
Labelling	via labelling field

Dimension





















50 mm x 50 mm x 30 mm (H x B x D), downward inclination 30°

Fig.	Article	Order no.
1	 MegaLine® Connect45 Pro wall outlet Keystone 50 x 50 / 1-fold	LKD 9ZQ0 1010 0000
2	 MegaLine® Connect45 Pro wall outlet Keystone 50 x 50 / dual	LKD 9ZQ0 1011 0000
3	 MegaLine® Connect45 Pro wall outlet Keystone 50 x 50 / 3-fold	LKD 9ZQ0 1012 0000
-	 40 mm surface-mounted housing	LKD 9A46 0086 0000
-	 Spacer frame for 1-fold surface-mounted housing, 10 mm	LKD 9A46 0088 0000

MegaLine®

Cu patch cords /
trunk cables



MegaLine® Cu patch cords / trunk cables			page
	Patch cord RJ45/RJ45	Cat. 5 / 100 MHz	144
	Patch cord RJ45/RJ45	Cat. 6 / 250 MHz	145
	Patch cord RJ45/RJ45	Cat. 6 / 500 MHz	146
	Patch cord RJ45/RJ45	Cat. 6 _A / 500 MHz	147
	LED patch cord RJ45/RJ45	Cat. 6 / 500 MHz with LED signal in connector	148
	LED patch cord RJ45/RJ45	Cat. 6 _A / 500 MHz with LED signal in connector	149
	Industrial patch cord RJ45/RJ45	Cat. 5 / 100 MHz	150
	Industrial patch cord RJ45/RJ45	Cat. 6 / 500 MHz	151
	Trunk cable	Cat. 7 _A	152
	Consolidation Point cable	Cat. 7 _A	153
	Patch cord TERA™		154
	Patch cord ARJ45™		156
	Trunk cable	Multi	157
	Trunk cable	Cat. 6 _A module	158
	Consolidation Point cable	Multi	159
	Consolidation Point cable	Cat. 6 _A modules	160
	Accessories for LED patch cords	• LED colour clip • LEO detector	161
	Accessories for patch cords	RJ45 colour coding clip	161
	Office cables		
	Data center cables		
	Industrial cables		

MegaLine® patch cord RJ45/RJ45 Cat. 5 / 100 MHz

shielded, Cat. 5, Class D, with coloured moulded boots



MegaLine® Patch 5D-RJ45

Description

The cable type used is suitable for transmission rates of up to 100 MHz. The pair shielding and the high-coverage copper braiding as overall shielding ensure excellent NEXT and impedance values.

The patch and connection cables are fitted at both ends with a shielded RJ45 plug and an overmoulded boot.

Applications

IEEE 802.3, 10Base-T, 100Base-T, 1000Base-T, IEEE 802.5 16MB ISDN, FDDI, ATM

Properties / type

EMC	Foil overall shielding
RJ45 plug	EN 60603-7
Electrical values	Cat. 5, Class D
Assignment	1:1
Standards	ISO/IEC 11801 / EN50173
	RoHS compliant with 2011/65/EU

Fire behaviour

Flame retardancy	IEC 60332-1-2
------------------	---------------

Accessories

see page 161 for description

MegaLine® Patch RJ45 colour coding clip in various colours for visual coding of the patch cords

Length	Article	Order no.				
		Grey (PVC)	Blue (PVC)	Turquoise green (LSOH)	Yellow (PVC)	Red (PVC)
m						
0.5	MegaLine® Patch 5D-RJ45	LKD 9AA1 0400 0000	LKD 9AA1 0410 0000	LKD 9AA1 0420 0000	LKD 9AA1 0430 0000	LKD 9AA1 0440 0000
1.0		LKD 9AA1 0401 0000	LKD 9AA1 0411 0000	LKD 9AA1 0421 0000	LKD 9AA1 0431 0000	LKD 9AA1 0441 0000
1.5		LKD 9AA1 0402 0000	LKD 9AA1 0412 0000	LKD 9AA1 0422 0000	LKD 9AA1 0432 0000	LKD 9AA1 0442 0000
2.0		LKD 9AA1 0403 0000	LKD 9AA1 0413 0000	LKD 9AA1 0423 0000	LKD 9AA1 0433 0000	LKD 9AA1 0443 0000
2.5		LKD 9AA1 0404 0000	LKD 9AA1 0414 0000	LKD 9AA1 0424 0000	LKD 9AA1 0434 0000	LKD 9AA1 0444 0000
3.0		LKD 9AA1 0405 0000	LKD 9AA1 0415 0000	LKD 9AA1 0425 0000	LKD 9AA1 0435 0000	LKD 9AA1 0445 0000
4.0		LKD 9AA1 0406 0000	LKD 9AA1 0416 0000	LKD 9AA1 0426 0000	LKD 9AA1 0436 0000	LKD 9AA1 0446 0000
5.0		LKD 9AA1 0407 0000	LKD 9AA1 0417 0000	LKD 9AA1 0427 0000	LKD 9AA1 0437 0000	LKD 9AA1 0447 0000
7.5		LKD 9AA1 0408 0000	LKD 9AA1 0418 0000	LKD 9AA1 0428 0000	LKD 9AA1 0438 0000	LKD 9AA1 0448 0000
10.0		LKD 9AA1 0409 0000	LKD 9AA1 0419 0000	LKD 9AA1 0429 0000	LKD 9AA1 0439 0000	LKD 9AA1 0449 0000

MegaLine® patch cord RJ45/RJ45 Cat. 6 / 250 MHz

unshielded, Cat. 6, Class E, with coloured moulded boots

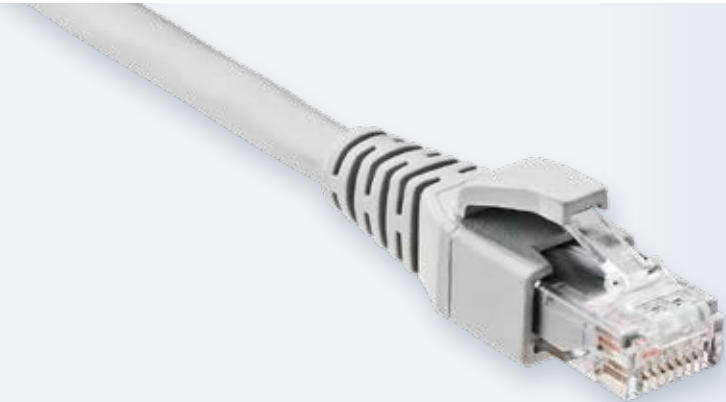

MegaLine® Patch 6E-RJ45U

Description

The cable type used is suitable for transmission rates of up to 250 MHz. Due to its construction, the patch cord offers outstanding NEXT and XT return losses.

The patch and connection cables are fitted at both ends with a shielded RJ45 plug and an overmoulded boot.

Applications

IEEE 802.3, 10Base-T, 100Base-T, 1000Base-T, IEEE 802.5 16MB, ISDN, FDDI, ATM

Properties / construction

RJ45 plug	EN 60603-7
Electrical values	Cat. 6, Class E
Assignment	1:1
Standards	ISO/IEC 11801/ EN50173
	RoHS compliant with 2011/65/EU

Fire behaviour

Smoke density	IEC 61034
Halogen-free	IEC 60754-2
Flame retardancy	IEC 60332-1-2

Accessories

see page 161 for description

MegaLine® Patch RJ45 colour coding clip in various colours for visual coding of the patch cords

Length	Article	Order no.
m		Grey (LSOH)
0.5	MegaLine® patch RJ45U	LKD 9AA5 0027 0000
1.0		LKD 9AA5 0028 0000
1.5		LKD 9AA5 0029 0000
2.0		LKD 9AA5 0030 0000
2.5		LKD 9AA5 0031 0000
3.0		LKD 9AA5 0032 0000
4.0		LKD 9AA5 0033 0000
5.0		LKD 9AA5 0034 0000
7.5		LKD 9AA5 0035 0000
10.0		LKD 9AA5 0036 0000

MegaLine® patch cord RJ45/RJ45 Cat. 6 / 250 MHz

shielded, Cat. 6, Class E_A, with coloured moulded boots



MegaLine® Patch 6EA-RJ45

Description

The cable type used is suitable for transmission frequencies of up to 250 MHz. The pair shielding and the high-coverage copper braiding as overall shielding ensure excellent NEXT and return loss values.

The patch and connection cables are fitted at both ends with a shielded RJ45 plug and an overmoulded boot.

Applications

Suitable for IEEE 802.3, 10Base-T, 100Base-T, 1000Base-T, 10GBase-T, IEEE 802.5 16MB, ISDN, FDDI, ATM

Properties / construction

EMC	Combined shielding (PiMf + braid)
RJ45 plug	EN 60603-7
Electrical values	Cat. 6, Class E _A
Assignment	1:1
Standards	ISO/IEC 11801 / EN50173
	RoHS compliant with 2011/65/EU

Fire behaviour

Smoke density	IEC 61034
Halogen-free	IEC 60754-2
Flame retardancy	IEC 60332-1-2

Accessories

see page 161 for description

MegaLine® Patch RJ45 colour coding clip

in various colours for visual coding of the patch cords

Length m	Article	Order no.				
		Grey (LSOH)	Blue (LSOH)	Turquoise green (LSOH)	Yellow (LSOH)	Red (LSOH)
0.5	MegaLine® Patch 6EA-RJ45	LKD 9AA2 1132 0000	LKD 9AA2 1152 0000	LKD 9AA2 1162 0000	LKD 9AA2 1142 0000	LKD 9AA2 1172 0000
1.0		LKD 9AA2 1133 0000	LKD 9AA2 1153 0000	LKD 9AA2 1163 0000	LKD 9AA2 1143 0000	LKD 9AA2 1173 0000
1.5		LKD 9AA2 1134 0000	LKD 9AA2 1154 0000	LKD 9AA2 1164 0000	LKD 9AA2 1144 0000	LKD 9AA2 1174 0000
2.0		LKD 9AA2 1135 0000	LKD 9AA2 1155 0000	LKD 9AA2 1165 0000	LKD 9AA2 1145 0000	LKD 9AA2 1175 0000
2.5		LKD 9AA2 1136 0000	LKD 9AA2 1156 0000	LKD 9AA2 1166 0000	LKD 9AA2 1146 0000	LKD 9AA2 1176 0000
3.0		LKD 9AA2 1137 0000	LKD 9AA2 1157 0000	LKD 9AA2 1167 0000	LKD 9AA2 1147 0000	LKD 9AA2 1177 0000
4.0		LKD 9AA2 1138 0000	LKD 9AA2 1158 0000	LKD 9AA2 1168 0000	LKD 9AA2 1148 0000	LKD 9AA2 1178 0000
5.0		LKD 9AA2 1139 0000	LKD 9AA2 1159 0000	LKD 9AA2 1169 0000	LKD 9AA2 1149 0000	LKD 9AA2 1179 0000
7.5		LKD 9AA2 1140 0000	LKD 9AA2 1160 0000	LKD 9AA2 1170 0000	LKD 9AA2 1150 0000	LKD 9AA2 1180 0000
10.0		LKD 9AA2 1141 0000	LKD 9AA2 1161 0000	LKD 9AA2 1171 0000	LKD 9AA2 1151 0000	LKD 9AA2 1181 0000

MegaLine® Patch cord RJ45/RJ45 Cat. 6_A/500 MHz

shielded, Cat. 6_A, Class E_A, with colour moulded boots



MegaLine® patch 6AEA-RJ45

Description

The cable type used is suitable for transmission frequencies of up to 500 MHz. The pair shielding and the high-coverage copper braiding as overall shielding ensure excellent NEXT and return loss values.

The patch and connection cables are fitted at both ends with a shielded RJ45 plug and an overmoulded boot.

Applications

Installation cable for use in structured cabling systems according to ISO/IEC 11801 and EN 50173-x. Ideal for all applications up to class E_A (video, data, telephony) >10 GbE acc. to IEEE 802.3 an, cable sharing, VoIP, PoE

Properties / construction

EMC	Combined shielding (PiMf + braid)
RJ45 plug	EN 60603-7
Electrical values	Cat. 6 _A , Class E _A
Assignment	1:1
Standards	ISO/IEC 11801 / EN50173
	RoHS compliant with 2011/65/EU

Fire behaviour

Smoke density	IEC 61034
Halogen-free	IEC 60754-2
Flame retardancy	IEC 60332-1-2

Accessories

see page 161 for description

MegaLine® Patch RJ45 colour coding clip

in various colours for visual coding of the patch cords

Length m	Article	Order no.				
		Grey (LSOH)	Blue (LSOH)	Turquoise green (LSOH)	Yellow (LSOH)	Red (LSOH)
0.5	MegaLine® Patch 6AEA-RJ45	LKD 9AA2 3020 0000	LKD 9AA2 3030 0000	LKD 9AA2 3040 0000	LKD 9AA2 3050 0000	LKD 9AA2 3060 0000
1.0		LKD 9AA2 3021 0000	LKD 9AA2 3031 0000	LKD 9AA2 3041 0000	LKD 9AA2 3051 0000	LKD 9AA2 3061 0000
1.5		LKD 9AA2 3022 0000	LKD 9AA2 3032 0000	LKD 9AA2 3042 0000	LKD 9AA2 3052 0000	LKD 9AA2 3062 0000
2.0		LKD 9AA2 3023 0000	LKD 9AA2 3033 0000	LKD 9AA2 3043 0000	LKD 9AA2 3053 0000	LKD 9AA2 3063 0000
2.5		LKD 9AA2 3024 0000	LKD 9AA2 3034 0000	LKD 9AA2 3044 0000	LKD 9AA2 3054 0000	LKD 9AA2 3064 0000
3.0		LKD 9AA2 3025 0000	LKD 9AA2 3035 0000	LKD 9AA2 3045 0000	LKD 9AA2 3055 0000	LKD 9AA2 3065 0000
4.0		LKD 9AA2 3026 0000	LKD 9AA2 3036 0000	LKD 9AA2 3046 0000	LKD 9AA2 3056 0000	LKD 9AA2 3066 0000
5.0		LKD 9AA2 3027 0000	LKD 9AA2 3037 0000	LKD 9AA2 3047 0000	LKD 9AA2 3057 0000	LKD 9AA2 3067 0000
7.5		LKD 9AA2 3028 0000	LKD 9AA2 3038 0000	LKD 9AA2 3048 0000	LKD 9AA2 3058 0000	LKD 9AA2 3068 0000
10.0		LKD 9AA2 3029 0000	LKD 9AA2 3039 0000	LKD 9AA2 3049 0000	LKD 9AA2 3059 0000	LKD 9AA2 3069 0000

Additional lengths on request

MegaLine® patch cord RJ45/RJ45 Cat. 6 / 250 MHz

shielded, Cat. 6, Class E_A, with LED light signal in plug

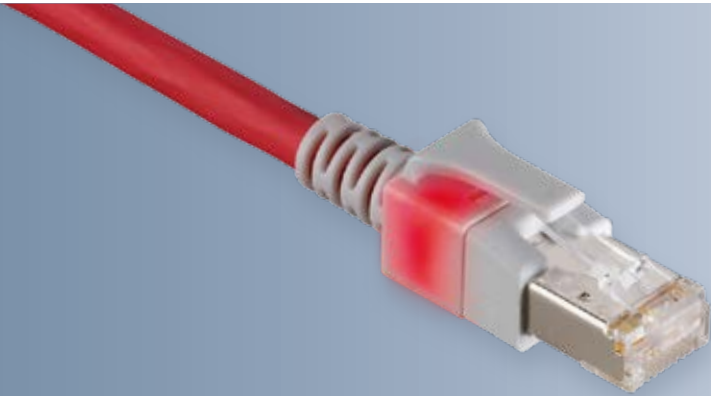

MegaLine® Patch LED 6EA-RJ45

Description

Especially for use in offices, industrial plants and data centers. The plug contains one red LED. The light signal is activated using a detector that is placed on a contact pair on the rear of the plug.

Three different signal types can be selected by repeatedly pressing the detector button:

→ continuous light / slow flashing / fast flashing

The other end of the LED patch cord reacts with the identical light signal in order to make it identifiable.

Applications

For use in structured cabling according to ISO/IEC 11801 and EN 50173-x. Ideal for all applications up to Class E_A (video, data, telephony)

>10 GbE acc. to IEEE 802.3 an, cable sharing, VoIP, PoE

Properties / construction

EMC	Combined shielding (PiMf + braid)
RJ45 plug	EN 60603-7
Electrical values	Cat. 6, Class E _A
Assignment	1:1
Standards	ISO/IEC 11801 / EN50173 RoHS compliant with 2011/65/EU

Fire behaviour

Smoke density	IEC 61034
Halogen-free	IEC 60754-2
Flame retardancy	IEC 60332-1-2

Accessories

see page 161 for description

MegaLine® Patch LED colour clip in various colours for visual coding of the patch cords

Length m	Article	Order no.					
		Grey (LSOH)	Blue (LSOH)	Aqua (LSOH)	Yellow (LSOH)	Red (LSOH)	Red (LSOH) Crossover
0.5	MegaLine® Patch LED 6EA-RJ45	LKD 9A09 0100 0000	LKD 9A09 0110 0000	LKD 9A09 0140 0000	LKD 9A09 0130 0000	LKD 9A09 0120 0000	LKD 9A09 0160 0000
1.0		LKD 9A09 0101 0000	LKD 9A09 0111 0000	LKD 9A09 0141 0000	LKD 9A09 0131 0000	LKD 9A09 0121 0000	LKD 9A09 0161 0000
1.5		LKD 9A09 0102 0000	LKD 9A09 0112 0000	LKD 9A09 0142 0000	LKD 9A09 0132 0000	LKD 9A09 0122 0000	LKD 9A09 0162 0000
2.0		LKD 9A09 0103 0000	LKD 9A09 0113 0000	LKD 9A09 0143 0000	LKD 9A09 0133 0000	LKD 9A09 0123 0000	LKD 9A09 0163 0000
2.5		LKD 9A09 0104 0000	LKD 9A09 0114 0000	LKD 9A09 0144 0000	LKD 9A09 0134 0000	LKD 9A09 0124 0000	LKD 9A09 0164 0000
3.0		LKD 9A09 0105 0000	LKD 9A09 0115 0000	LKD 9A09 0145 0000	LKD 9A09 0135 0000	LKD 9A09 0125 0000	LKD 9A09 0165 0000
4.0		LKD 9A09 0106 0000	LKD 9A09 0116 0000	LKD 9A09 0146 0000	LKD 9A09 0136 0000	LKD 9A09 0126 0000	LKD 9A09 0166 0000
5.0		LKD 9A09 0107 0000	LKD 9A09 0117 0000	LKD 9A09 0147 0000	LKD 9A09 0137 0000	LKD 9A09 0127 0000	LKD 9A09 0167 0000
7.5		LKD 9A09 0108 0000	LKD 9A09 0118 0000	LKD 9A09 0148 0000	LKD 9A09 0138 0000	LKD 9A09 0128 0000	LKD 9A09 0168 0000
10.0		LKD 9A09 0109 0000	LKD 9A09 0119 0000	LKD 9A09 0149 0000	LKD 9A09 0139 0000	LKD 9A09 0129 0000	LKD 9A09 0169 0000

additional lengths on request

MegaLine® Patch cord RJ45/RJ45 Cat. 6_A/500 MHz

shielded, Cat. 6_A, Class E_A, with LED light signal in plug

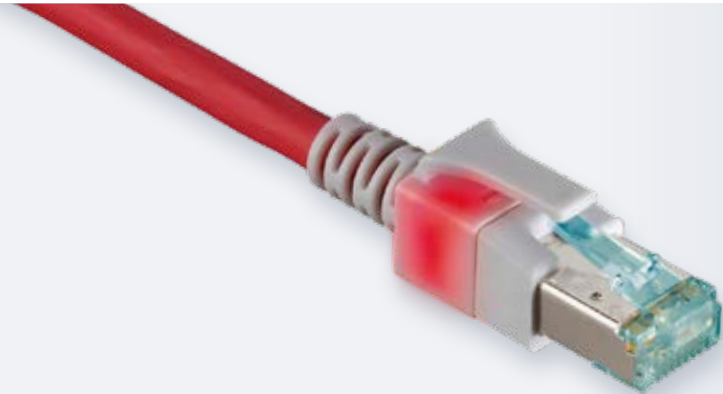

MegaLine® Patch LED 6A EA-RJ45

Description

Especially for use in offices, industrial plants and data centers. The plug contains one red LED. The light signal is activated using a detector that is placed on a contact pair on the rear of the plug.

Three different signal types can be selected by repeatedly pressing the detector button:

→ continuous light / slow flashing / fast flashing

The other end of the LED patch cord reacts with the identical light signal in order to make it identifiable.

Applications

For use in structured cabling according to ISO/IEC 11801 and EN 50173-x. Ideal for all applications up to Class E_A (video, data, telephony)

>10 GbE acc. to IEEE 802.3 an, cable sharing, VoIP, PoE.

Properties / construction

EMC	Combined shielding (PiMf + braid)
RJ45 plug	EN 60603-7
Electrical values	Cat. 6 _A , Class E _A
Assignment	1:1
Standards	ISO/IEC 11801 / EN50173 / IEC 60603-7-51 RoHS compliant with 2011/65/EU

Fire behaviour

Smoke density	IEC 61034
Halogen-free	IEC 60754-2
Flame retardancy	IEC 60332-1-2
Fire load	0.33 (reference value)

Accessories

see page 161 for description

MegaLine® Patch LED colour clip in various colours for visual coding of the patch cords

Length m	Article	Order no.				
		Grey (LSOH)	Blue (LSOH)	Turquoise green (LSOH)	Yellow (LSOH)	Red (LSOH)
0.5	MegaLine® Patch LED 6A EA-RJ45	LKD 9A09 0290 0000	LKD 9A09 0270 0000	LKD 9A09 0300 0000	LKD 9A09 0260 0000	LKD 9A09 0280 0000
1.0		LKD 9A09 0291 0000	LKD 9A09 0271 0000	LKD 9A09 0301 0000	LKD 9A09 0261 0000	LKD 9A09 0281 0000
1.5		LKD 9A09 0292 0000	LKD 9A09 0272 0000	LKD 9A09 0302 0000	LKD 9A09 0262 0000	LKD 9A09 0282 0000
2.0		LKD 9A09 0293 0000	LKD 9A09 0273 0000	LKD 9A09 0303 0000	LKD 9A09 0263 0000	LKD 9A09 0283 0000
2.5		LKD 9A09 0294 0000	LKD 9A09 0274 0000	LKD 9A09 0304 0000	LKD 9A09 0264 0000	LKD 9A09 0284 0000
3.0		LKD 9A09 0295 0000	LKD 9A09 0275 0000	LKD 9A09 0305 0000	LKD 9A09 0265 0000	LKD 9A09 0285 0000
4.0		LKD 9A09 0296 0000	LKD 9A09 0276 0000	LKD 9A09 0306 0000	LKD 9A09 0266 0000	LKD 9A09 0286 0000
5.0		LKD 9A09 0297 0000	LKD 9A09 0277 0000	LKD 9A09 0307 0000	LKD 9A09 0267 0000	LKD 9A09 0287 0000
7.5		LKD 9A09 0298 0000	LKD 9A09 0278 0000	LKD 9A09 0308 0000	LKD 9A09 0268 0000	LKD 9A09 0288 0000
10.0		LKD 9A09 0299 0000	LKD 9A09 0279 0000	LKD 9A09 0309 0000	LKD 9A09 0269 0000	LKD 9A09 0289 0000

Additional lengths on request

MegaLine® industrial patch cord RJ45/RJ45 Cat. 5 / 100 MHz

shielded, Cat. 5, Class D, with yellow moulded boots

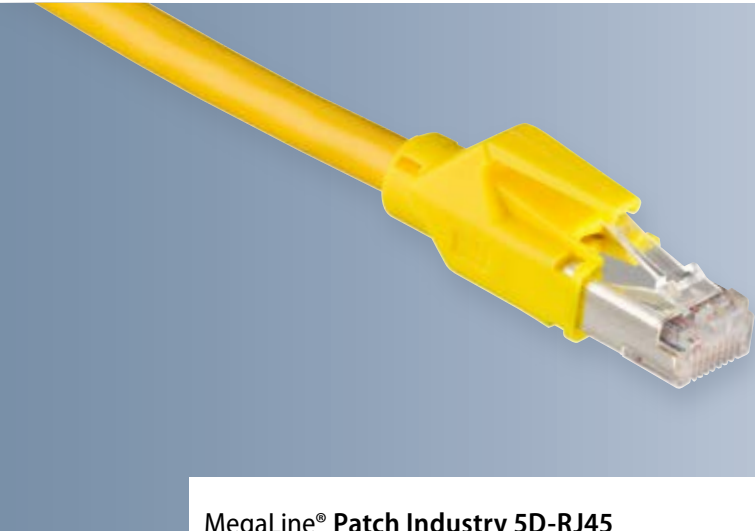

MegaLine® Patch Industry 5D-RJ45

Description

The cable type used is suitable for transmission rates of up to 100 MHz. The pair shielding and the high-coverage copper braiding as overall shielding ensure excellent NEXT and return loss values.

The patch and connection cables are fitted at both ends with a shielded RJ45 plug and boot.

The "superflex" version is excellent for demanding industrial applications (e.g. drag chains).

Applications

Suitable for IEEE 802.3, 10Base-T, 100Base-T, 1000Base-T, 10GBase-T, IEEE 802.5 16MB, ISDN, FDDI, ATM

Properties / construction

EMC	Shield (braid)
RJ45 plug	EN 60603-7
Electrical values	Cat. 5, Class D
Cable/boot	Yellow (PUR superflex) / yellow
Standards	ISO/IEC 11801 / EN50173
	RoHS compliant with 2011/65/EU

Fire behaviour

Smoke density	IEC 61034-1/2
Halogen-free	IEC 60754-1/2
Flame retardancy	IEC 60332-2-2

Length	Article	Order no.
m		Yellow (PUR)
10.0	MegaLine® Patch Industry 5D-RJ45	LKD 9AA7 0084 0000
20.0		LKD 9AA7 0155 0000
30.0		LKD 9AA7 0082 0000
40.0		LKD 9AA7 0179 0000
50.0		LKD 9AA7 0085 0000

MegaLine® industrial patch cord RJ45/RJ45 Cat. 6 / 250 MHz

shielded, Cat. 6, Class E_A, with black boots

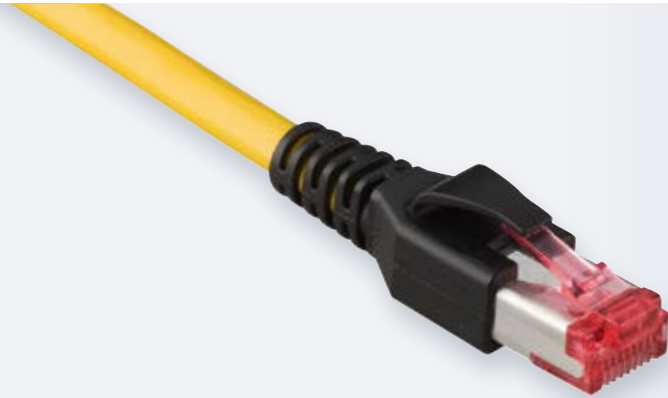

MegaLine® Patch Industry 6EA-RJ45

Description

The cable type used is suitable for transmission frequencies of up to 250 MHz. The pair shielding and the high-coverage copper braiding as overall shielding ensure excellent NEXT and return loss values.

The patch and connection cables are fitted at both ends with a shielded RJ45 plug.

Applications

Suitable for IEEE 802.3, 10Base-T, 100Base-T, 1000Base-T, 10GBase-T, IEEE 802.5 16MB, ISDN, FDDI, ATM

Properties / construction

EMC	Combined shielding (PiMf + braid)
RJ45 plug	EN 60603-7
Electrical values	Cat. 6, Class E _A
Cable/boot	yellow (PUR) / black
Standards	ISO/IEC 11801 / EN50173
	RoHS compliant with 2011/65/EU

Fire behaviour

Smoke density	IEC 61034-1/2
Halogen-free	IEC 60754-1/2
Flame retardancy	IEC 60332-2-2

Accessories

see page 161 for description

MegaLine® Patch RJ45 colour coding clip in various colours for visual coding of the patch cords

Length	Article	Order no.
m		Yellow (PUR)
0.5	MegaLine® Patch Industry 6EA-RJ45	LKD 9AA7 0160 0000
1.0		LKD 9AA7 0161 0000
1.5		LKD 9AA7 0162 0000
2.0		LKD 9AA7 0163 0000
2.5		LKD 9AA7 0164 0000
3.0		LKD 9AA7 0165 0000
5.0		LKD 9AA7 0166 0000
7.5		LKD 9AA7 0167 0000
10.0		LKD 9AA7 0168 0000

MegaLine® Connect100 trunk cable

pre-assembled trunk, MegaLine® Connect100 Cable plug Cat. 7_A

On request, with documented acceptance measurement on CD.



MegaLine® Connect100 trunk cable, Cat.7_A

Description

The trunk cable is based on a G20 S/F data cable – pre-assembled at both ends with Cat 7_A MegaLine® Connect100 cable plugs .

Thanks to its high quality components, the pre-assembled cable meets the requirements for the Permanent Link (**typ. > 5 m, Cat. 7_A modules**) of Class F_A according to ISO/IEC 11801 and EN 50173 for 10 Gigabit Ethernet and the channel (Class II) according to the current draft of ISO/IEC 11801-99-1.

Channel Class II

→ Recommended minimum configuration:

5 m horizontal cable and 2 m patch cord each

→ Maximum configuration:

26 m horizontal cable and 2 m patch cord each at both ends

Construction

Cable	G20 S/F (4x2x AWG 22/1) (Order no.: LKD 7KS8 0020 0000)
Side A / side B	MegaLine® Connect100 cable plug Cat. 7 _A

Standards

- ISO/IEC 11801
- EN 50173-1
- IEEE 802.3at (PoE+)

Article	Length*	Order no.
MegaLine® Connect100 Trunk cable	10.0 m	LKD 9AA6 1782 0000
	15.0 m	LKD 9AA6 1820 0000
	20.0 m	LKD 9AA6 1783 0000
	30.0 m	LKD 9AA6 1821 0000
	40.0 m	LKD 9AA6 1822 0000
	50.0 m	LKD 9AA6 1823 0000

* standard lengths, other lengths and types of cable
(also pre-assembled at one end) on request

MegaLine® Connect100 Consolidation Point cable

pre-assembled CP cable, MegaLine® Connect100 Cable plug Cat. 7_A

On request, with documented acceptance measurement on CD.



MegaLine® Connect100 CP cable, Cat.7_A

Description

The Consolidation Point cable is based on a G20 S/F flex data cable, assembled at both ends with a MegaLine® Connect100 jack and a TERA™ / ARJ45™ connector.

Thanks to its high quality components in combination with a CP link (> 10 m) the pre-assembled cable meets the requirements for the Class F_A Permanent Link according to ISO/IEC 11801 Amendment 2 for 10 Gigabit Ethernet.

Construction

Cable	G20 S/F flex (4x2x AWG26/7) (Order no.: LKD 7KS8 0013 0000)
Side A	MegaLine® Connect100 Cat. 7 _A cable plug
Side B	TERA™ plug / ARJ45™ plug

Standards

- ISO/IEC 11801
- EN 50173-1
- IEEE 802.3at (PoE+)

Article	Length*	Order no.
MegaLine® Connect100 CP cable (TERA)	5.0 m	LKD 9A06 1945 0000
	10.0 m	LKD 9A06 1946 0000
	15.0 m	LKD 9A06 1947 0000
	20.0 m	LKD 9A06 1948 0000
	25.0 m	LKD 9A06 1949 0000
MegaLine® Connect100 CP cable (ARJ45)	5.0 m	LKD 9A06 1950 0000
	10.0 m	LKD 9A06 1951 0000
	15.0 m	LKD 9A06 1952 0000
	20.0 m	LKD 9A06 1953 0000
	25.0 m	LKD 9A06 1954 0000

* Standard lengths / additional lengths on request

MegaLine® patch cord TERA™



MegaLine® Patch TERA™

Description

The patch cord and connection cable are fitted with TERA™ or RJ45 plugs as required (the RJ45 plug has a moulded boot). The appropriate cable type for the application is used for assembly. Cable type F10-120 S/F flex used is designed for a bandwidth of up to 1000 MHz with 4-pair assignment.

Standards

- ISO/IEC 11801 / EN50173
- RoHS compliant with 2011/65/EU

Applications

- 10BASE-T / 100BASE-T2
- Token ring
- ISDN
- Telephony
- Telephony
- any
- 2-pair connecting line
- 4-pair connecting line

Wiring





- TERA™ 2-pair on RJ45
- TERA™ 2-pair on RJ45
- TERA™ 2-pair on RJ45
- TERA™ 1-pair on RJ45
- TERA™ 1-pair on RJ11
- TERA™ 4-pair on RJ45
- TERA™ on TERA™
- TERA™ on TERA™

Applications	10BASE-T / 100BASE-T2	Token ring	ISDN	Telephony
Patch cords				
Wiring	TERA™ 2-pair on RJ45	TERA™ 2-pair on RJ45	TERA™ 2-pair on RJ45	TERA™ 1-pair on RJ45

Length	Article	Order no.			Article	Order no.
		10BASE-T / 100BASE-T2	Token ring	ISDN		
1.0	MegaLine® Patch TERA™ 2-pair on RJ45 (F10-120 S/F flex)	LKD 9A04 0000 0000	LKD 9A04 0006 0000	LKD 9A04 0012 0000	MegaLine® Patch TERA™ 1-pair on RJ45 (326 flex)	LKD 9A04 0022 0000
2.0		LKD 9A04 0001 0000	LKD 9A04 0007 0000	LKD 9A04 0013 0000		LKD 9A04 0023 0000
3.0		LKD 9A04 0002 0000	LKD 9A04 0008 0000	LKD 9A04 0014 0000		LKD 9A04 0024 0000
5.0		LKD 9A04 0003 0000	LKD 9A04 0009 0000	LKD 9A04 0015 0000		LKD 9A04 0025 0000

TERA™ is a registered trademark of the Siemon Company



Applications	Telephony	any	2-pair connecting line	4-pair connecting line
Patch cords				
Wiring	TERA™ 1-pair on RJ11	TERA™ 4-pair on RJ45	TERA™ on TERA™	TERA™ on TERA™

Length	Article	Order no.	Article	Article	Order no.	Order no.	
m		Telephony		any		2-pair connecting line 4-pair connecting line	
1.0	MegaLine® Patch TERA™ 1-pair on RJ11 (326 flex)	LKD 9A04 0017 0000	MegaLine® Patch TERA™ 4-pair to RJ45 (F10-120 S/F flex)	LKD 9A04 0039 0000	MegaLine® Patch TERA™ on TERA™ (F10-120 S/F flex)	LKD 9A04 0026 0000	LKD 9A04 0032 0000
2.0		LKD 9A04 0018 0000		LKD 9A04 0040 0000		LKD 9A04 0027 0000	LKD 9A04 0033 0000
3.0		LKD 9A04 0019 0000		LKD 9A04 0041 0000		LKD 9A04 0028 0000	LKD 9A04 0034 0000
5.0		LKD 9A04 0045 0000		LKD 9A04 0042 0000		LKD 9A04 0029 0000	LKD 9A04 0035 0000

TERA™ is a registered trademark of the Siemon Company

MegaLine® patch cord ARJ45™

shielded, with grey moulded boots

Wiring
ARJ45™-ARJ45™

Wiring
ARJ45™-RJ45

MegaLine® Patch ARJ45

Description

The patch cord and connection cable are fitted with ARJ45™ or RJ45 plugs as required.

Standards

- ISO/IEC 11801 / EN50173
- RoHS compliant with 2011/65/EU

Length	Article	Order no.	Article	Order no.
1.0 m	MegaLine® 7AFA ARJ45	LKD 9A08 0134 0000	MegaLine® patch 6AEA ARJ45-RJ45	LKD 9A08 0104 0000
2.0 m		LKD 9A08 0135 0000		LKD 9A08 0105 0000
3.0 m		LKD 9A08 0136 0000		LKD 9A08 0106 0000
5.0 m		LKD 9A08 0137 0000		LKD 9A08 0107 0000

MegaLine® truck cable

pre-assembled multi-cable with MegaLine® Connect45, or MegaLine® Connect100



On request, with documented acceptance measurement on CD.

MegaLine® Connect45 Multi-Trunk, n-fold
MegaLine® Connect100 Multi-Trunk, n-fold

Description

The trunk cable is based on a multi-data cable (F6-90 S/F; F10-115 S/F; G20 S/F) – assembled at both ends with MegaLine® Connect45 jacks and/or MegaLine® Connect100 cable plugs. Thanks to its high quality components, the pre-assembled cable meets the requirements for the Permanent Link of the relevant class in accordance with ISO/IEC 11801 and EN 50173.

Construction

- Cable Multi-data cable (F6-90 S/F; F10-115 S/F; G20 S/F)
- Jack modules MC100 ▶ VK format
MC45 ▶ Keystone, VK format, ELine
- Side A / side B various jacks, see table
- Whip length 0.35 m

Standards

- ISO/IEC 11801
- EN 50173-1

Cable type	Cable length max.	Cat. 6 _A		Cat. 7 _A		Cat. 8.2	
		Jack A	Jack B	Jack A	Jack B	Jack A	Jack B
		MC45 Pro MC45 RJ45 MC100 RJ45		MC100 ARJ MC100 TERA™ MC100 Interface		MC100 ARJ MC100 TERA™ MC100 Interface	
horizontal Multi *	4-fold F6-90 S/F	35 m	✓	✓			
	6-fold F6-90 S/F	35 m	✓	✓			
	4-fold F10-115 S/F	35 m	✓	✓	25 m	✓	✓
	6-fold F10-115 S/F	35 m	✓	✓	25 m	✓	✓
	4-fold G20 S/F	35 m	✓	✓	25 m	✓	✓
	6-fold G20 S/F	35 m	✓	✓	25 m	✓	✓

* more on request

✓ available

MegaLine® trunk cable

pre-assembled single cable with MegaLine® Connect45 jack modules Cat. 6_A

On request, with documented acceptance measurement on CD.

Jack module Cat. 6_A
Aqua marking

MegaLine® Connect45 Trunk Cat. 6_A modules
MegaLine® Connect100 Trunk Cat. 6_A modules

Description

The trunk cable is based on an F6-90 S/F data cable, pre-assembled at both ends with MegaLine® Connect45 jacks. Thanks to its high quality components, the pre-assembled cable meets the requirements for the Permanent Link (> 1 m, Cat. 6_A modules) of Class E_A in accordance with ISO/IEC 11801 and EN 50173 for 10 Gigabit Ethernet. The length specifications relate to the 2-connector model.

Cable type	Cable length Standard max.	Cat. 6 _A		
		Jack A	Jack B	
		MC45 Pro MC45 RJ45 MC100 RJ45		
horizontal installation	E5-60 U/F	90 m	✓	✓
	E5-70 F/F	90 m	✓	✓
	E5-70 S/F	90 m	✓	✓
	F6-90 S/F	90 m	✓	✓
	ML Pro 1000	90 m	✓	✓
	F10-115 S/F	90 m	✓	✓
	ML Pro 1200	90 m	✓	✓
	F10-125 S/F	90 m	✓	✓
	ML Pro 1300	90 m	✓	✓
	F10-130 S/F	90 m	✓	✓
	ML Pro 1500	90 m	✓	✓
	G12-150	90 m	✓	✓
	G20	90 m	✓	✓

* more on request

✓ available

Article	Cable	Modules	Length*	Jack module format VK	Jack module format Keystone®	Jack module format ELine
MegaLine® Connect45 trunk with RJ45 jack	MegaLine® F6-90 S/F	Cat. 6 _A modules	5.0 m	LKD 9AA6 1173 0000	LKD 9AA6 1132 0000	LKD 9AA6 1447 0000
			10.0 m	LKD 9AA6 1174 0000	LKD 9AA6 1133 0000	LKD 9AA6 1448 0000
			15.0 m	LKD 9AA6 1175 0000	LKD 9AA6 1134 0000	LKD 9AA6 1449 0000
			30.0 m	LKD 9AA6 1176 0000	LKD 9AA6 1135 0000	LKD 9AA6 1450 0000
			90.0 m	LKD 9AA6 1177 0000	LKD 9AA6 1136 0000	LKD 9AA6 1451 0000

* Standard lengths / additional lengths on request

Standards

- ISO/IEC 11801
- EN 50173-1
- IEC60603-7-51 (Cat. 6_A)

Construction

- Cable various types, see table
- Jack modules MC100 ▶ VK format
MC45 ▶ Keystone, VK format, ELine
- Side A / side B various jacks, see table

MegaLine® Consolidation Point cable

pre-assembled multi-cable with MegaLine® Connect45 or MegaLine® Connect100



On request, with documented acceptance measurement on CD.

MegaLine® Connect45 Multi-CP cable flex
MegaLine® Connect100 Multi-CP cable flex

Description

The trunk cable is based on a multi-data cable (F6-90 S/F flex; F10-120 S/F flex; G20 S/F flex) – pre-assembled on both sides with MegaLine® Connect45 jacks and/or MegaLine® Connect100 cable plug flex. Thanks to its high quality components, the pre-assembled cable meets the requirements for the Permanent Link of the relevant class in accordance with ISO/IEC 11801 and EN 50173.

Construction

- Cable Multi-data cable (F6-90 S/F flex; F10-120 S/F flex; G20 S/F flex)
- Jack modules MC100 ▶ VK format
MC45 ▶ Keystone, VK format, ELine
- Side A / side B see table
- Whip length 0.35 m

Standards

- ISO/IEC 11801
- EN 50173-1

Cable type	Cable length max.	Cat. 6 _A		Cat. 7 _A			Cat. 8.2		
		Connector SL	Jack	Connector	Jack B	Connector	Jack B		
		RJ45	MC45 Pro MC45 RJ45 MC100 RJ45	ARJ45 TERA™ 4P	MC100 ARJ MC100 TERA™ MC100 Interface	ARJ45 TERA™ 4P	MC100 ARJ MC100 TERA™ MC100 Interface		
flex Multi *	4-fold F6-90 S/F	35 m	✓	✓					
	6-fold F6-90 S/F	35 m	✓	✓					
	4-fold F10-115 S/F	35 m	✓	✓	25 m	✓	✓		
	6-fold F10-115 S/F	35 m	✓	✓	25 m	✓	✓		
	4-fold G20 S/F	35 m	✓	✓	25 m	✓	✓	26 m	✓
	6-fold G20 S/F	35 m	✓	✓	25 m	✓	✓	26 m	✓

* more on request

✓ available

MegaLine® Consolidation Point cable

pre-assembled single cable with MegaLine® Connect45 jack modules Cat. 6_A

On request, with documented acceptance measurement on CD.



MegaLine® Connect45 CP cable flex
MegaLine® Connect100 CP cable flex

Description

The Consolidation Point cable is based on a F10-120 S/F flex data cable – assembled at both ends with a MegaLine® Connect45 jack and a RJ45 SmartLock connector.

Thanks to its high quality components in combination with a CP link (> 10 m), the pre-assembled cable meets the requirements for the Permanent Link of Class E_A in accordance with ISO/IEC 11801 Amendment 2 for 10 Gigabit Ethernet.

Standards

- ISO/IEC 11801
- EN 50173-1
- IEC60603-7-51

Construction

- Cable various types, see table
- Jack modules MC100 ▶ VK format
MC45 ▶ Keystone, VK format, ELine
- Side A / side B various jacks, see table
RJ45 plug (SmartLock Cat. 6_A)

Cable type	Cable length max.	Cat. 6 _A		
		Connector SL	Jack	
		RJ45	MC45 Pro MC45 RJ45 MC100 RJ45	
flex	E5-70 S/F flex	50 m	✓	✓
	F6-90 S/F flex	50 m	✓	✓
	F10-120 S/F flex	50 m	✓	✓
	G20 flex	50 m	✓	✓

* more on request

✓ available

Article	Cable	Modules	Length*	Jack module format VK	Jack module format Keystone®	Jack module format ELine
MegaLine® Connect45 trunk CP cable with RJ45 jack	MegaLine® F10-120 S/F flex	Cat. 6 _A modules	5.0 m	LKD 9AA2 3353 0000	LKD 9AA2 3343 0000	LKD 9AA2 3955 0000
			10.0 m	LKD 9AA2 3354 0000	LKD 9AA2 3344 0000	LKD 9AA2 3331 0000
			15.0 m	LKD 9AA2 3355 0000	LKD 9AA2 3345 0000	LKD 9AA2 3332 0000
			20.0 m	LKD 9AA2 3356 0000	LKD 9AA2 3346 0000	LKD 9AA2 3333 0000
			25.0 m	LKD 9AA2 3357 0000	LKD 9AA2 3347 0000	LKD 9AA2 3334 0000

* Standard lengths / additional lengths on request

MegaLine® Patch accessories

for LED patch cords



MegaLine® Patch LED colour clip
MegaLine® Patch LED detector

Accessories

Colour clip: For visual coding of the LED patch cords.
Can be installed by simply snapping into the RJ45 plugs.

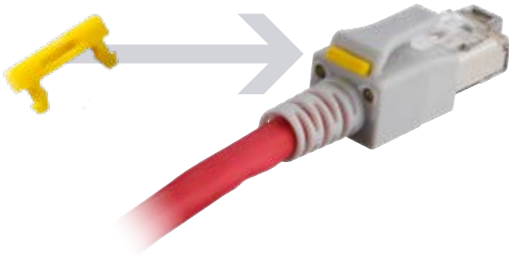

Detector:

To feed in the light signal for patch cord identification.

Batteries included:

4 x LR41

Article	Colour	Order no.
MegaLine® Patch LED colour clip (100 pc.)	● Rape yellow RAL 1021	LKD 9A09 0180 0000
	● Fire red RAL 3000	LKD 9A09 0181 0000
	● Sky blue RAL 5015	LKD 9A09 0182 0000
	● Turquoise green RAL 6016	LKD 9A09 0183 0000
MegaLine® Patch LED detector (1 pc.)		LKD 9A09 0190 0000

MegaLine® Patch accessories

for patch cord RJ45



MegaLine® Patch RJ45 colour coding clip

Accessories

Colour coding clip for visual coding of the patch cords.
Can be installed by simply pushing on.

Compatibility

MegaLine® Patch 5D-RJ45

MegaLine® Patch 6E-RJ45U

MegaLine® Patch 6EA-RJ45

MegaLine® Patch 6AEA-RJ45

MegaLine® Patch Industry 6EA-RJ45

Article	Colour	Order no.
MegaLine® Patch RJ45 colour coding clip (100 pc.)	● Light grey RAL 7035	LKD 9AW1 6031 0000
	● Turquoise green RAL 6016	LKD 9AW1 6032 0000
	● Sky blue RAL 5015	LKD 9AW1 6033 0000
	● Fire red RAL 3000	LKD 9AW1 6034 0000
	● Pastel orange RAL 2003	LKD 9AW1 6035 0000
	● Rape yellow RAL 1021	LKD 9AW1 6036 0000
	● Jet black RAL 9005	LKD 9AW1 6037 0000



VarioLine®

System periphery in copper and FO

VarioLine®

Modular, robust and easy to install

VarioLine® is designed to fit perfectly with the modular LEONI connection systems MegaLine® Connect100, MegaLine® Connect45 and the VK format.

What is more, all systems can be integrated with Keystone® dimensions and commonly used FO cable couplings.



VarioLine® system periphery in copper and fiber			page
• VarioLine® CP – Consolidation Point programme			165
o dc	Consolidation Point housing	with DIN rail clip	166
• VarioLine® UF – underfloor systems			169
o	System overview		170
o	Support plates for underfloor systems	• for installation of wall boxes • for installation of adapter plates	172
o	Adapter plates for underfloor systems	for installation in VarioLine® UF support plates	174
o	Support plates for underfloor systems	for installation of adapter plates	176
o	Blind cover	for VarioLine® UF support plates	177
o	Office application		
dc	Data center application		



VarioLine® CP Consolidation Point programme

for copper and FO connectivity

The Consolidation Point programme is an efficient and low-cost solution for highly flexible storey, data center or industrial cabling.

In office cabling (EN 50173-2), Consolidation Points (CP) offer highly flexible cabling solutions for fast-changing office facilities as a collection point between the floor distributor (FD) and the telecommunication outlet (TO).

The CP can be installed in a double floor, false ceiling, column or duct. From there, flexible lines (CP cables) lead to the data sockets at the workplace.

CP cabling links permanently installed cables to modular or mobile office systems such as partition walls or office furniture in which the TO is already installed. In industrial cabling, this is referred to as an intermediate distributor (ID) – a connection between the floor distributor (FD) and the telecommunication outlet (TO) that allows temporary machine cabling, for example (EN 50173-3).

In a data center, CPs offer an additional marshalling option (EN 50173-5) as local distribution points (LDP) between the zone distributor (ZD) and the equipment outlet (EO).

The robust VarioLine® Consolidation Points are made of galvanized sheet metal and are available in various sizes.

Various module panels are available for VarioLine® CP housings:

- MegaLine® Connect100
- MegaLine® Connect45 (Keystone® and VK format)
- MegaLine® Connect45 Pro
- GigaLine® SC Duplex

On request we can expand the product programme quickly and flexibly to include additional modular panels – for modular use with copper and FO systems.

What VarioLine® CP has to offer:

- The patch end is protected by means of a pivoting cover with a brush strip (optional).
- Support for incoming cables and patch cords can be provided by means of cable ties.
- The housings can be earthed if necessary.
- The DIN rail clip included with the housing extends the range of potential uses with rail clips.



VarioLine® Consolidation Point housing

with DIN rail clip

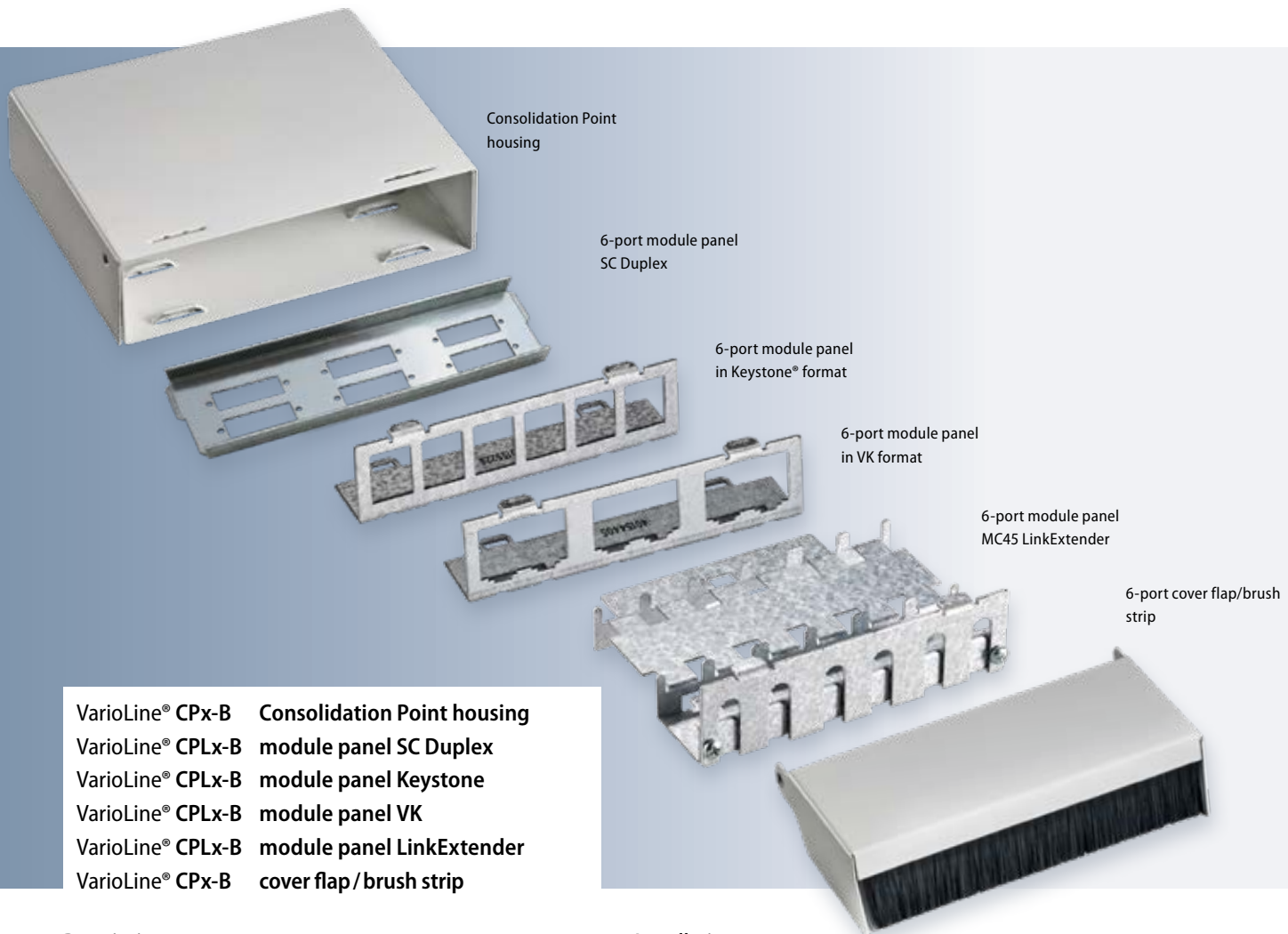

Description

For installation in a double floor or false ceiling. CP housing with strain relief by means of cable ties (not included). Can be fitted with MegaLine® Connect45 or MegaLine® Connect100 modules.

A cover flap with integrated brush strip can be optionally inserted on the patch side.

- Modular (exchangeable module panel)
- optionally with 6 / 12 or 24 ports
- rugged casing made of galvanised sheet metal
- free of hazardous substances

Installation







- CP housing is attached by rail clip (matching clip included)
- Alternative attachment using screws or impact dowels (not included)
- Module panel is attached by snapping into housing
- Modules are attached by snapping into the module panel



Assembly example:
housing with mounted
rail clip



Assembly example:
MegaLine® Connect Keystone®

Housing	SC Duplex	Keystone® for jack modules MegaLine® Connect45 (Keystone®)	VK format for jack modules MegaLine® Connect45 (VK) and MegaLine® Connect100	LinkExtender for MegaLine® Connect45 LinkExtender	cover flap / brush strip
					

Ports	Order no.					
6	LKD 9ZE6 1007 0000	LKD 9ZE6 1041 0000	LKD 9ZE6 1064 0000	LKD 9ZE6 1014 0000	LKD 9ZE6 1092 0000	LKD 9ZE6 1008 0000
12	LKD 9ZE6 1074 0000	-	LKD 9ZE6 1067 0000	LKD 9ZE6 1017 0000	LKD 9ZE6 1093 0000	LKD 9ZE6 1073 0000
24	LKD 9ZE6 1075 0000	-	LKD 9ZE6 1068 0000	LKD 9ZE6 1018 0000	LKD 9ZE6 1094 0000	LKD 9ZE6 1076 0000



VarioLine® UF – underfloor systems

Support plate solution – modular & universal

The VarioLine® UF underfloor systems (floor outlet solutions) offer an efficient and low-cost solution for completing copper and FO systems.

They provide a high degree of flexibility in offices. Workplaces can be connected to the energy and IT grid without the usual cable tangle. The modular and universal support plate solutions are available for all commonly available underfloor systems (e.g. Ackermann or Electraplan).

The support plate replaces the device carrier, so it provides maximum space for cable feed. The slanted feed and exit ensures secure ducting even in very low intermediate floors.

The use of adapter plates allows low-cost, efficient installation of the entire range of LEONI connection technology in both copper and FO technology.



Example of an underfloor solution by LEONI in an OBO Bettermann floor outlet

VarioLine® UF – underfloor systems

System overview

MegaLine® Connect100 Interface

MegaLine® Connect100 4K7A

MegaLine® Connect100 8C7A

MegaLine® Connect100 RJ45

MegaLine® Connect45 (in VK format)

VarioLine® jacks

VarioLine® UF AP3-VK
for max. 3 MegaLine® Connect100 modules or
for max. 3 MegaLine® Connect45 modules
(in VK format)
page 174

VarioLine® adapter plate

MegaLine® Connect45 (in ELine format)
page 132

VarioLine® UF AP3-MC45E
for max. 3 MegaLine® Connect45 modules
(in ELine format)
page 175

MegaLine® Connect45 (in Keystone® format)
page 130

VarioLine® UF AP3-MC45K
for max. 3 MegaLine® Connect45 modules
(in Keystone® format)
Seite174

VarioLine®
support plate

VarioLine® UF TA2
for Ackermann
GES 2, 4, 6, R4, R7
page 173

VarioLine® UF TA3
for Ackermann
GES 9, R7, R9
page 173

VarioLine® UF TEK3
for Electraplan KDR series
(old design)
page 173

VarioLine® UF TEV3
for Electraplan
VQ12, VR12, VR10
page 173



VarioLine® support plates for underfloor systems

for installation of wall boxes



Fig. 1
Support plate VarioLine® UF TOA2-2
for Ackermann GES 2, 4, 6, R4, R7

Fig. 2
Support plate VarioLine® UF TOA3-2
for Ackermann GES 9, R7, R9



Fig. 3
Support plate VarioLine® UF TOA3-3
for Ackermann GES 9, R7, R9

VarioLine® UF TOA2-2 / UF TOA3-2

Description

UF TOA2-2 → for installation of max. 2 wall boxes with central plate 50 mm x 50 mm and side attachment or one wall box with surrounding ring.

UF TOA3-2 → for installation of max. 2 wall boxes with central plate 50 mm x 50 mm and side attachment or two wall boxes with surrounding ring.

For installation in Ackermann device inserts.

Housing

Support plate powder-coated sheet metal, 1.5 mm
Colour Jet black, RAL 9005

VarioLine® UF TOA3-3

Description

For installation of max. 3 wall boxes with central plate 50 mm x 50 mm and side attachment or 2 wall boxes with surrounding ring.

For installation in Ackermann device inserts.

Housing

Support plate powder-coated sheet metal, 1.5 mm
Colour Jet black, RAL 9005

Fig.	Article	Order no.
1	VarioLine® UF TOA2-2 (1 pc.)	LKD 9ZE6 0014 0000
2	VarioLine® UF TOA3-2 (1 pc.)	LKD 9ZE6 0012 0000

Fig.	Article	Order no.
3	VarioLine® UF TOA3-3 (1 pc.)	LKD 9ZE6 0013 0000

VarioLine® support plates for underfloor systems

for installation of adapter plates

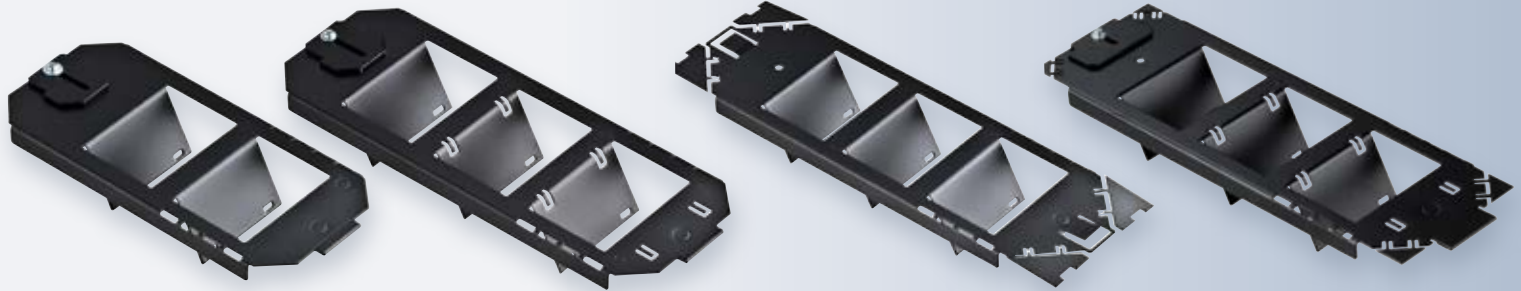

Fig. 1
Support plate VarioLine® UF TA2
for Ackermann
GES 2, 4, 6, R4, R7

Fig. 2
Support plate VarioLine® UF TA3
for Ackermann
GES 9, R7, R9

Fig. 1
Support plate VarioLine® UF TEK3
for Electraplan KDR series
(old design)

Fig. 2
Support plate VarioLine® UF TEV3
for Electraplan
VQ12, VR12, VR10

VarioLine® UF TA2 / UF TA3

Description

For installation of max. 2 or 3 adapter plates.
For installation in Ackermann device inserts.

Compatibility

UF TA2	Ackermann GES 2, 4, 6, R4, R7
UF TA3	Ackermann GES 9, R7, R9

Housing

Support plate	powder-coated sheet metal, 1.5 mm
Colour	Jet black, RAL 9005

Accessories (optional)

Cable tray VarioLine® UF K1 / VarioLine® UF K2.
Adjustable cable strain relief for up to 9 individual cables.

VarioLine® UF TEK3 / UF TEV3

Description

For installation of max. 3 adapter plates.
For installation in Electraplan device inserts.

Compatibility

UF TEK3	Electraplan KDR series (old design)
UF TEV3	Electraplan VQ12, VR12, VR10

Housing

Support plate	powder-coated sheet metal, 1.5 mm
Colour	Jet black, RAL 9005

Accessories (optional)

Cable tray VarioLine® UF K1 / VarioLine® UF K2 .
Adjustable cable strain relief for up to 9 individual cables.

Fig.	Article	Order no.
1	VarioLine® UF TA2 (1 pc.)	LKD 9ZE6 0001 0000
2	VarioLine® UF TA3 (1 pc.)	LKD 9ZE6 0002 0000

Fig.	Article	Order no.
1	VarioLine® UF TEK3 (1 pc.)	LKD 9ZE6 0008 0000
2	VarioLine® UF TEV3 (1 pc.)	LKD 9ZE6 0042 0000

VarioLine® adapter plates for underfloor systems

for installation in VarioLine® UF support plates

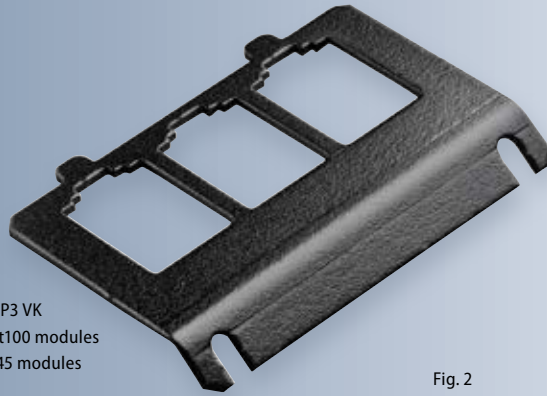

Fig. 1
Adapter plate VarioLine® UF AP3 VK
for max. 3 MegaLine® Connect100 modules
or max. 3 MegaLine® Connect45 modules
(VK format)



Fig. 2
Adapter plate VarioLine® UF AP3 MC45K
for max. 3 MegaLine® Connect45 modules
(Keystone®)

VarioLine® UF AP3-VK VarioLine® UF AP3-MC45

Description

Adapter plate for installation in VarioLine® UF support plates.
For installation of max. 3 modules.

- With self-adhesive labelling strips for personal labelling
- 2 nut and washer assemblies incl.

Compatibility

UF AP3 VK	→ for max. 3 MegaLine® Connect100 modules or max. 3 MegaLine® Connect45 modules (VK format)
UF AP3 MC45K	→ for max. 3 MegaLine® Connect45 modules (Keystone®)

Construction

Adapter plate	sheet metal, 1,5 mm
Surface	Zn – black, conductive

Matching jacks	MegaLine® Connect100 Interface	MegaLine® Connect100 4K7A	MegaLine® Connect100 8C7A	MegaLine® Connect100 RJ45	MegaLine® Connect45 (VK format)	MegaLine® Connect45 (Keystone®)
VarioLine® UF AP3 VK (compatible with VK format)						
VarioLine® UF AP3 MC45K						

Fig.	Article	Order no.:
1	VarioLine® UF AP3-VK (1 pc.)	LKD 9A46 0118 0000
2	VarioLine® UF AP3-MC45 (1 pc.)	LKD 9ZE6 0044 0000

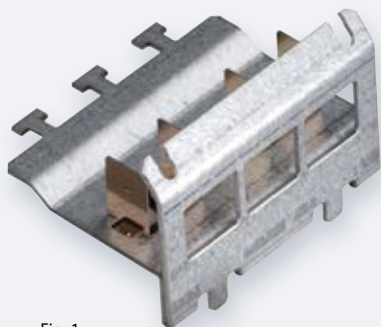

Fig. 1
Adapter plate VarioLine® UF AP3-MC45E
for max. 3 MC45 modules (in ELine format)



Fig. 2
Adapter plate VarioLine® UF AP4-SCD
for max. 4 SC Duplex couplings

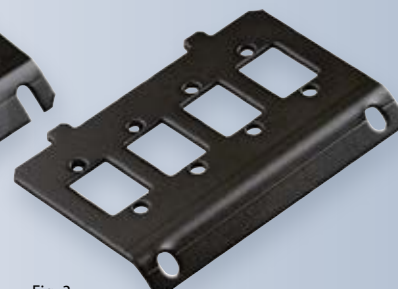

Fig. 3
Adapter plate VarioLine® UF AP4-LCD
for max. 4 LC Duplex couplings

VarioLine® UF AP3-MC45E

Description

Adapter plate for installation in VarioLine®UF support plates.
For installation of max. 3 MC45 modules (in ELine format).

- With earthing or reference connection
- With self-adhesive labelling strips for personal labelling
- 2 nut and washer assemblies incl.

Construction

Adapter plate sheet metal, 1.5 mm
Surface: Aluminium-zinc

VarioLine® UF AP4-SCD / UF AP4-LCD

Description

Adapter plate for installation in VarioLine®UF support plates.
For installation of max. 4 SC or LC Duplex couplings.

- With self-adhesive labelling strips for personal labelling.
- 2 nut and washer assemblies incl.

Compatibility

UF AP4-SCD for max. 4 SC-Duplex or SC Duplex/ ST couplings
UF AP4-LCD for max. 4 LC Duplex, SC Simplex or E-2000 couplings

Construction

Adapter plate sheet metal, 1.5 mm
Surface: ZN – black, conductive

matching jacks	MegaLine® Connect45 (in ELine format)	GigaLine® SC Duplex	GigaLine® SC-Duplex/ST	GigaLine® SC Simplex	GigaLine® LC Duplex	GigaLine® E-2000
VarioLine® UF AP3-MC45E						
VarioLine® UF AP4-SCD						
VarioLine® UF AP4-LCD						

Fig.	Article	Order no.
1	VarioLine® UF AP3-MC45E (1 pc.)	LKD 9ZE6 0106 0000

Fig.	Article	Order no.
2	VarioLine® UF AP4-SCD (1 pc.)	LKD 9FZZ 0078 0000
3	VarioLine® UF AP4-LCD (1 pc.)	LKD 9FZZ 0079 0000

VarioLine® support plates for underfloor systems

for installation of adapter plates



Fig. 1
Support plate VarioLine® UF TA2 3VK
for Ackermann
GES 2, 4, 6, R4, R7

Fig. 2
Support plate VarioLine® UF TA3 3VK
for Ackermann
GES 9, R7, R9



Support plate VarioLine® UF TEV3 3VK
for Electraplan
VQ12, VR12, VR10

VarioLine® UF TA2 3VK / UF TA3 3VK

Description

Support plate with max. 2 or 3 integrated adapter plates.
For installation in Ackermann device inserts.

Compatibility

UF TA2 3VK	Ackermann GES 2, 4, 6, R4, R7
UF TA3 3VK	Ackermann GES 9, R7, R9

Housing

Support plate	powder-coated sheet metal, 1.5 mm
Colour	Jet black, RAL 9005

Accessories (optional)

Cable tray VarioLine® UF K1 / VarioLine® UF K2
Adjustable cable strain relief for up to 9 individual cables

VarioLine® UF TEK3 3VK / UF TEV3 3VK

Description

Support plate with max. 3 integrated adapter plates.
For installation in Ackermann device inserts.

Compatibility

UF TEK3 3VK	Electraplan KDR series (old design)
UF TEV3 3VK	Electraplan VQ12, VR12, VR10

Housing

Support plate	powder-coated sheet metal, 1.5 mm
Colour	Jet black, RAL 9005

Accessories (optional)

Cable tray VarioLine® UF K1 / VarioLine® UF K2
Adjustable cable strain relief for up to 9 individual cables

Matching jacks	MegaLine® Connect100 Interface	MegaLine® Connect100 4K7A	MegaLine® Connect100 8C7A	MegaLine® Connect100 RJ45	MegaLine® Connect45 (VK format)
VarioLine® UF TA2 3VK / UF TA3 3VK					
VarioLine® UF TEK3 3VK / UF TEV3 3VK					

Fig.	Article	Order no.
1	VarioLine® UF TA2 3VK (1 pc.)	LKD 9ZE6 0046 0000
2	VarioLine® UF TA3 3VK (1 pc.)	LKD 9ZE6 0045 0000

Fig.	Article	Order no.
1	VarioLine® UF TEK3 3VK (1 pc.)	LKD 9ZE6 0048 0000
2	VarioLine® UF TEV3 3VK (1 pc.)	LKD 9ZE6 0047 0000

VarioLine® blind cover

for VarioLine® UF support plates



Fig. 3
Blind cover
UF support plates

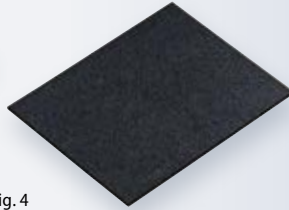

Fig. 4
Blind cover
UF support plates
for wall box inserts

VarioLine® UF BP-T VarioLine® UF BP-TO

Description

Blind cover to close an unused opening in the VarioLine® UF support plate (incl. 2 nut and washer assemblies).

Compatibility

UF BP-T	for VarioLine® UF support plates
UF BP-TO	for VarioLine® UF support plates for wall box inserts

Housing

Support plate	powder-coated sheet metal, 1.5 mm
Colour	Jet black, RAL 9005

Fig.	Article	Order no.
1	VarioLine® UF K1 (1 pc.)	LKD 9ZE6 0003 0000
2	VarioLine® UF K2 (1 pc.)	LKD 9ZE6 0004 0000

Fig.	Article	Order no.
3	VarioLine® UF BP-T (1 pc.)	LKD 9ZE6 0005 0000
4	VarioLine® UF BP-TO (1 pc.)	LKD 9ZE6 0015 0000

Acceptance measurement

of MegaLine® cabling systems

The acceptance measurement for the MegaLine® cabling systems for the channel or permanent link is carried out in accordance with the requirements of SO/IEC 11801 or EN 50173, (3rd Edition).

Further standards regarding the acceptance measurement (measurement procedure): **DIN EN 50346** and **DIN EN 61935**.



Acceptance measurement Class E

MegaLine® Connect100 / MegaLine® Connect45

For acceptance measurement according to Class E, the measuring device is set to a measuring bandwidth of 250 MHz.

For details, refer to the instructions on setting the measuring device. Information can be found under:

> www.idealindustries.de

> www.flukenetworks.com

> www.itnetworks.softing.com

Ensure the measuring adapters are connected to the measuring device and securely engaged. Take the corresponding measuring cable and ensure it is firmly plugged in. If synchronisation is required, this is then carried out according to the instructions for the device.

	Standard acceptance: Channel or Permanent Link
System	 <p>MegaLine® Connect45</p>
Approved measuring devices	 <p>LanTEK III-1000 (available from Ideal Industries)</p> <p>Fluke DSX 8000 (available from Fluke Networks)</p>  <p>Softing WireXpert 4500 (available from Softing IT Networks)</p>
Approved measuring cables	 <p>Measuring cable set Order no. LKD 9AW3 0023 0000</p>

Acceptance measurement Class E_A

MegaLine® Connect100 / MegaLine® Connect45

For acceptance measurement according to Class E_A, the measuring device is set to a measuring bandwidth of 500 MHz.

For details, refer to the instructions on setting the measuring device. Information can be found under:







> www.idealindustries.de

> www.flukenetworks.com

> www.itnetworks.softing.com

Ensure the measuring adapters are connected to the measuring device and securely engaged. Take the corresponding measuring cable and ensure it is firmly plugged in. If synchronisation is required, this is then carried out according to the instructions for the device.

Standard acceptance: Channel or Permanent Link

System	 <p>MegaLine® Connect100 jack module RJ45</p>	 <p>MegaLine® Connect45</p>
Approved measuring devices	 <p>LanTEK III-1000 (available from Ideal Industries)</p> <p>Fluke DSX 8000 (available from Fluke Networks)</p>  <p>Softing WireXpert 4500 (available from Softing IT Networks)</p>	 <p>LanTEK III-1000 (available from Ideal Industries)</p> <p>Fluke DSX 8000 (available from Fluke Networks)</p>  <p>Softing WireXpert 4500 (available from Softing IT Networks)</p>
Approved measuring cables	 <p>Measuring cable set Order no. LKD 9AW3 0023 0000</p>	 <p>Measuring cable set Order no. LKD 9AW3 0023 0000</p>

Acceptance measurement Class F_A

MegaLine® Connect100

For acceptance measurement according to Class F_A, the measuring device is set to a measuring bandwidth of 1000 MHz.

For details, refer to the instructions on setting the measuring device.

> www.idealindustries.de

> www.flukenetworks.com

> www.itnetworks.softing.com

Ensure the measuring adapters are connected to the measuring device and securely engaged. Take the corresponding measuring cable and ensure it is firmly plugged in. Carry out the field zeroing on the device according to the operating instructions.

Standard acceptance: Channel or Permanent Link

Standard acceptance: Channel or Permanent Link	
System	<div style="display: flex; justify-content: space-around;"> <div style="text-align: center;">  <p>MegaLine® Connect100 jack module 4K7A</p> </div> <div style="text-align: center;">  <p>MegaLine® Connect100 jack module 8C7A</p> </div> </div>
Approved measuring devices	<div style="display: flex; justify-content: space-around;"> <div style="text-align: center;">  <p>LanTEK III-1000 (available from Ideal Industries)</p> </div> <div style="text-align: center;">  <p>LanTEK III-1000 (available from Ideal Industries)</p> </div> </div> <div style="display: flex; justify-content: space-around; margin-top: 20px;"> <div style="text-align: center;">  <p>Fluke DSX 8000 (available from Fluke Networks)</p> </div> <div style="text-align: center;">  <p>Fluke DSX 8000 (available from Fluke Networks)</p> </div> </div> <div style="display: flex; justify-content: space-around; margin-top: 20px;"> <div style="text-align: center;">  <p>Softing WireXpert 4500 (available from Softing IT Networks)</p> </div> <div style="text-align: center;">  <p>Softing WireXpert 4500 (available from Softing IT Networks)</p> </div> </div>
Approved measuring cables	<div style="display: flex; justify-content: space-around;"> <div style="text-align: center;">  <p>Measuring cable set Order no. LKD 9A04 0166 0000</p> </div> <div style="text-align: center;">  <p>Measuring cable set Order no. LKD 9AW3 0024 0000</p> </div> </div>

Channel

Class E/E_A/F/F_A

Frequency/MHz	1	16	100	250	500	600	1000
---------------	---	----	-----	-----	-----	-----	------

Channel class E

Return loss	19.0	18.0	12.0	8.0			
Insertion loss	4.0	8.3	21.7	35.9			
NEXT	65.0	53.2	39.9	33.1			
PS NEXT/dB	62.0	50.6	37.1	30.2			
ACR-N/dB	61.0	44.9	18.2	-2.8			
PS-ACR-N/dB	58.0	42.3	15.4	-5.8			
ACR-F/dB	63.3	39.2	23.3	15.3			
PS-ACR-F/dB	60.3	36.2	20.3	12.3			
Runtime/μs	0.580	0.553	0.548	0.546			
Runtime difference/μs	0.050	0.050	0.050	0.050			

Channel Class E_A

Return loss	19.0	18.0	12.0	8.0	6.0		
Insertion loss	4.0	8.2	20.9	33.9	49.3		
NEXT	65.0	53.2	39.9	33.1	27.9		
PS NEXT/dB	62.0	50.6	37.1	30.2	24.8		
ACR-N/dB	61.0	45.0	19.0	-0.8	-21.4		
PS-ACR-N/dB	58.0	42.4	16.2	-3.7	-24.5		
ACR-F/dB	63.3	39.2	23.3	15.3	9.3		
PS-ACR-F/dB	60.3	36.2	20.3	12.3	6.3		
Runtime/μs	0.580	0.553	0.548	0.546	0.546		
Runtime difference/μs	0.050	0.050	0.050	0.050	0.050		

Channel class F

Return loss	19.0	18.0	12.0	8.0	49.3	8.0	
Insertion loss	4.0	8.1	20.8	33.8	52.4	54.6	
NEXT	65.0	65.0	62.9	56.9	49.4	51.2	
PS NEXT/dB	62.0	62.0	59.9	53.9	3.1	48.2	
ACR-N/dB	61.0	56.9	42.1	23.1	0.1	-3.4	
PS-ACR-N/dB	58.0	53.9	39.1	20.1	32.6	-6.4	
ACR-F/dB	65.0	57.5	44.4	37.8	29.6	31.3	
PS-ACR-F/dB	62.0	54.5	41.4	34.8	8.0	28.3	
Runtime/μs	0.580	0.553	0.548	0.546	0.546	0.545	
Runtime difference/μs	0.030	0.030	0.030	0.030	0.03	0.030	

Channel Class F_A

Return loss	19.0	18.0	12.0	8.0	8.0	8.0	6.0
Insertion loss	4.0	8.0	20.3	32.5	46.7	51.4	67.6
NEXT	65.0	65.0	65.0	59.1	53.6	52.1	47.9
PS NEXT/dB	62.0	62.0	62.0	56.1	50.6	49.1	44.9
ACR-N/dB	61.0	57.0	44.7	26.7	6.9	0.7	-19.6
PS-ACR-N/dB	58.0	54.0	41.7	23.7	3.9	-2.3	-22.6
ACR-F/dB	65.0	63.3	47.4	39.4	33.4	31.8	27.4
PS-ACR-F/dB	62.0	60.3	44.4	36.4	30.4	28.8	24.4
Runtime/μs	0.580	0.553	0.548	0.546	0.546	0.545	0.545
Runtime difference/μs	0.030	0.030	0.030	0.030	0.030	0.030	0.030

Permanent Link

Class E/E_A/F/F_A

Frequency/MHz	1	16	100	250	500	600	1000
Permanent Link Class E							
Return loss	21.0	20.0	14.0	10.0			
Insertion loss	4	7.1	18.5	30.7			
NEXT	65	54.6	41.8	35.3			
PS Next/dB	62	52.2	39.3	32.7			
ACR-N/dB	61	47.5	23.3	4.7			
PS ACR-N/dB	58	45.1	20.8	2			
ACR-F/dB	64.2	40.1	24.2	16.2			
PS ACR-F/dB	61.2	37.1	21.2	13.2			
Runtime/μs	0.521	0.496	0.491	0.490			
Runtime difference/μs	0.044	0.044	0.044	0.044			
Permanent Link Class E_A							
Return loss	21.0	20.0	14.0	10.0	8.0		
Insertion loss	4	7	17.8	28.9	42.1		
NEXT	65	54.6	41.8	35.3	29.2/27.9		
PS Next/dB	62	52.2	39.3	32.7	26.4/24.8		
ACR-N/dB	61	47.6	24	6.4	-12.9/14.2		
PS ACR-N/dB	58	45.2	21.5	3.8	-15.7/16.3		
ACR-F/dB	64.2	40.1	24.2	16.2	10.2		
PS ACR-F/dB	61.2	37.1	21.2	13.2	7.2		
Runtime/μs	0.521	0.496	0.491	0.490	0.490		
Runtime difference/μs	0.044	0.044	0.044	0.044	0.044		
Permanent Link Class F							
Return loss	21.0	20.0	14.0	10.0	10.0	10.0	
Insertion loss	4	6.9	17.7	28.8	42.1	46.6	
NEXT	65	65	65	60.4	55.9	54.7	
PS Next/dB	62	62	62	57.4	52.9	51.7	
ACR-N/dB	61	58.1	47.3	31.6	13.8	8.1	
PS ACR-N/dB	58	55.1	44.3	28.6	10.8	5.1	
ACR-F/dB	65	59.3	46	39.2	34	32.6	
PS ACR-F/dB	62	56.3	43	36.2	31	29.6	
Runtime/μs	0.521	0.496	0.491	0.490	0.490	0.489	
Runtime difference/μs	0.026	0.026	0.026	0.026	0.026	0.026	
Permanent Link Class F_A							
Return loss	21.0	20.0	14.0	10.0	10.0	10.0	8.0
Insertion loss	4	6.8	17.3	27.7	39.8	43.9	57.6
NEXT	65	65	65	61.7	56.1	54.7	49.1/47.9
PS Next/dB	62	62	62	58.7	53.1	51.7	46.1/44.9
ACR-N/dB	61	58.2	47.7	34	16.4	10.8	-8.5/9.7
PS ACR-N/dB	58	55.2	44.7	31	13.4	7.8	-11.5/12.7
ACR-F/dB	65	64.7	48.8	40.8	34.8	33.2	28.8
PS ACR-F/dB	62	61.7	45.8	37.8	31.8	30.2	25.8
Runtime/μs	0.521	0.496	0.491	0.490	0.490	0.489	0.489
Runtime difference/μs	0.026	0.026	0.026	0.026	0.026	0.026	0.026

* = 3-connector link from three providers

Alien crosstalk



Alien crosstalk describes the undesirable mutual electrical influence between parallel links in the installation duct and in the vicinity of the patch panels. In contrast to NEXT and attenuation, disturbance through alien crosstalk cannot be compensated for electronically.

Alien crosstalk has become extremely important from a technical point of view. The ISO/IEC 11801 Amendment 1 (Generic cabling for customer premises) takes this into account with relevant specifications for the new transmission Classes E_A (500 MHz) and F_A (1000 MHz).

MegaLine® S/FTP cabling systems meet the requirements for alien crosstalk with a high degree of reliability. External influences from adjacent channels are prevented and suppressed simultaneously via the double shielding of the S/FTP cables and the modular shielding of the connectivity.

Alien crosstalk is attenuated by >100 dB (a factor of 100,000). These characteristics are design-specific and do not change in the installation environment. IEEE 802.3an considers shielded cabling systems to be the preferred solution.

Frequency MHz	Minimum PS ANEXT dB	
	Class E _A , F	Class F _A
1	67.0	67.0
100	60.0	67.0
250	54.0	67.0
500	49.5	64.5
1000	N/A	60.0

Requirements of PS Alien Next and PS AACR-F
at selected frequencies

Frequency MHz	Minimum PS AACR-F dB	
	Class E _A , F	Class F _A
1	67.0	67.0
100	37.0	52.0
250	29.0	44.0
500	23.0	38.0
1000	N/A	32.0

Requirements of PS Alien Next and PS AACR-F
at selected frequencies

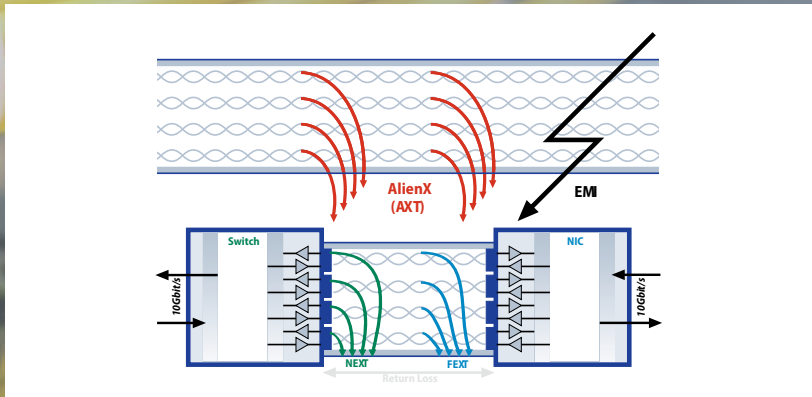

Transmission model and alien crosstalk 10GBASE-T

Coupling attenuation

Coupling attenuation evaluates the overall EMC behaviour of a cable or individual link. The coupling attenuation consists of the shielding attenuation and the asymmetrical attenuation taken together and defines the degree of reduction of electrical influences on a signal path.

If the coupling attenuation for Class E_A and F transmission links is 10.0 dB better than in the table below and for Class F_A transmission links 25.0 dB better than in the table below, the values for the parameters Power Sum Alien NEXT (PS ANEXT) and Power Sum Alien ACR-F (PS AACR-F) are complied with automatically as a result of the design, making it unnecessary to demonstrate them explicitly.

Class	Frequency MHz	Min. coupling attenuation dB
D, E, E _A , F, F _A	$30 \leq f \leq \text{Note 2}$	$80 - 20 \lg(f)$

Note 1: Round down calculated values greater than 40 dB to 40 dB.

Note 2: Coupling attenuation is measured up to 1000 MHz but the limit is determined by the upper frequency of the class being tested.

Requirements of coupling attenuation for cabling classes D to F_A

Coupling attenuation for Class E_A and F:

> $90 - 20 \lg(f)$, > 50 dB up to 100 MHz

Coupling attenuation for Class F_A:

> $105 - 20 \lg(f)$, > 65 dB up to 100 MHz

Due to the coupling mechanisms, this connection only applies for shielded cablings and not for unshielded ones.

MegaLine® measuring results

All MegaLine® cabling systems with modular or individual shielding have met the extended requirements for coupling attenuation according to Class E_A. It was possible to conclude the comprehensive assessments with the relevant certifications.

MegaLine® measuring results

All MegaLine® cabling systems with modular or individual shielding have met the extended requirements for coupling attenuation according to Class E_A. VK 4K7 even meets the requirements of Class F_A. It was possible to conclude the comprehensive assessments with the relevant certifications.



MegaLine® @home
One network – no limits



MegaLine®@home – all data in one

Go for the convenient home option – one data network for an entire lifetime

In the near future, we will be able to manage and use our entire home environment using just a few screens such as TVs, smartphones or tablets. This will enable increasingly universal use of applications such as TV viewing, games, streaming and storage, as well as facilitating the control of electrical appliances, lighting, HVAC and security.

With rates of up to 10 Gbit/s, data will be available in the blink of an eye from any wall socket. Films, images and music will take just a few moments to download, and surfing the internet will become a truly new experience.

LEONI provides the necessary neutral data network in the form of MegaLine®@home. Just like an electricity supply, any data socket will be able to power any application. With the right modules installed, it will be possible to control building automation systems and hard drive recorders while on the go. Integrating the domestic wireless LAN network is extremely straightforward, too.

Convenience, entertainment, building automation and security are high-priority factors for MegaLine@home, and it is also able to accommodate your own personal creativity.

Basic components

MegaLine® Box:

The MegaLine® Box is the control centre for your network. All components can be neatly installed and are protected from unauthorised access. All household applications are distributed and controlled from here. It is available in a range of colours and can be integrated in furniture units (min. 55 cm interior depth).

MegaLine® home 600

The data cable MegaLine® home 600 forms the backbone of the network, transmitting data to the wall outlets at a rate of 10 Gbit/s. This means the network is perfectly prepared for a long service life. Related products even offer the option of providing the power supply for end devices and setting up an outdoor connection.

MegaLine® Connect

The jacks and plugs of the MegaLine® Connect series are the interfaces between cable and wall outlet, ensuring that all applications can make the most of the high data speeds.

MegaLine® Patch

The patch cords and connection cables of the MegaLine® Patch series are used to distribute all applications in the MegaLine® Box to the various connections and hook up the end devices to the wall outlets. This is the final link in the transmission chain.

Convenience components

Components:

Active devices are required to turn LEONI's basic network into a true multimedia network.

The retail sector provides an extensive range of products for this purpose, leaving nothing to be desired.

- Telephone system and wireless LAN router
- Switch
- IP video cameras
- BUS system
- Repeater
- Satellite system
- Sensors and actuators
- End devices
- Installation material

Convenience for all

A data network is the basis for distributing all data within the household,

Providing easy access to centrally stored data such as photos, films and music and making it easier than ever to control heat, lighting and alarm systems.

Connection to the internet is no problem either of course, so everyone to get the full fun out of surfing and gaming for example, or streaming films and photographs.

Communication



Fast surfing and phone calls are becoming increasingly integrated. The MegaLine®@home data network is ready and waiting for upgrades and already offers data rates of 10 Gbit/s.

- Voice over IP
- Telephone, fax, scanner, Smartphone, tablet
- PC, laptop

Entertainment



Watching TV, gaming, surfing, listening to music, looking at photographs or streaming – everything is available all the time, wherever you want. The neutral network structures even allow the various applications to be exchanged. MegaLine®@home interconnects all devices, turning the TV into a slide projector or a hi-fi system, for example ...

- TV, TV over IP, photographs
- Gaming consoles
- Music, radio
- PC, surfing, tablets
- Power over Ethernet (PoE)

Building automation



Forgotten to switch the light off? Is the cooker still on? No worries! The interface to the in-house BUS system allows all devices to be operated conveniently even when you're out and about.

- Heat, light, shading
- Household appliances
- Occupancy and smoke detector
- Renewable energies, garden irrigation

Safety



Whether outdoor surveillance, occupancy detector or alarm control: MegaLine®@home makes it all possible, and provides the connection so you can check the current state of your home at any time.

- Network safety
- Alarm systems
- Surveillance cameras
- Access control and safety

Building technology and multimedia

Planning example

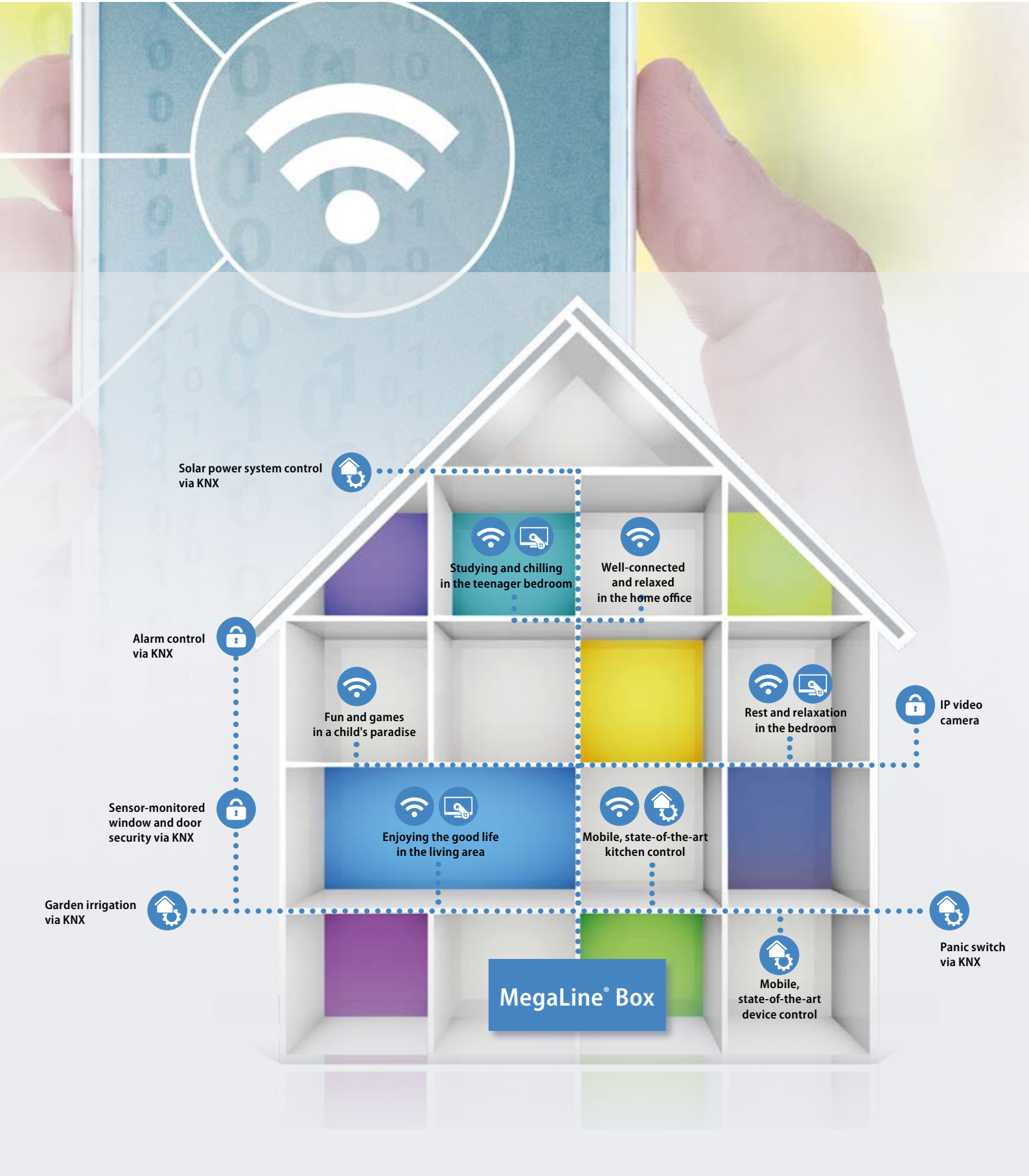

MegaLine®@home – at a glance

Product range

Accessories



Wall outlet



Wall socket dual

Connectors



LinkExtender Class E_x

Cable plug



Installation components



Cabling

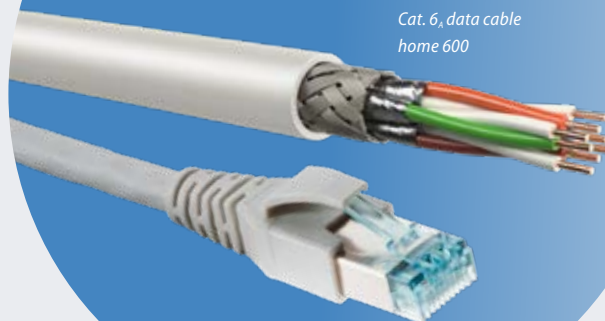

Product	Order no.
MegaLine® home 600, 350 m	LK9 7KS7 0304 0035
MegaLine® home 600, 100 m	LK9 7KS7 0304 0010
MegaLine® Box 5 RU 19" + 4 RU 10"	LKD 9ZE6 2001 0000
MegaLine® Connect45 jack module (Keystone format) Cat. 6 _x ISO/IEC	LKD 9A50 1010 0000
MegaLine® Connect45 LinkExtender Class E _x shielded without cable plug	LKD 9A50 0010 0000
MegaLine® Connect45 RJ-45 plug, field-configurable	LKD 9A50 0020 0000
Keystone wall socket, dual with design capability	LKD 9A50 1110 0000
Keystone 24-port panel Grey ● fixed / empty Black ●	LKD 9A50 1200 0000 LKD 9A50 1201 0000
MegaLine® Connect45 assembly tool	LKD 9A50 4001 0000
MegaLine® Connect45 protecting cap (packing unit = 25 pc.)	LKD 9A50 4003 0000

Product	Order no.
MegaLine® Connect45 cable plug AWG 24/-22 AWG 26/-27 (packing unit = 25 pc.)	LKD 9A50 4010 0000 LKD 9A50 4011 0000
Stripping tool for PiMF	LKD 9AW1 6043 0000
MegaLine® Patch 6AEA-RJ45 Patch cord shielded, 4-pair	●● 1.0 m LKD 9A02 3021 0000
	●● 3.0 m LKD 9A02 3025 0000
	●● 1.0 m LKD 9A02 3031 0000
	●● 3.0 m LKD 9A02 3035 0000
	●● 1.0 m LKD 9A02 3041 0000
	●● 3.0 m LKD 9A02 3045 0000
	●● 1.0 m LKD 9A02 3051 0000
	●● 3.0 m LKD 9A02 3055 0000
●● 1.0 m LKD 9A02 3061 0000	
●● 3.0 m LKD 9A02 3065 0000	

* other common lengths and colours available on request

LEONI & Partner

Industry-wide competence from a single source



Specialist electricians, specialist wholesalers and LEONI – an unbeatable combination.

The combination of specialist fitter, wholesaler and manufacturer gives you a wide range of options in terms of product diversity, fast availability and outstanding specialist expertise – at every level.

With MegaLine®@home, LEONI provides the basis for your home network, not just with high-quality products but also the experience gathered from more than 20 years of network system technology of the very highest quality. The individual products are manufactured in Germany to top industrial and environmental standards and exceed all current data technology requirements.

Specialist expertise

LEONI

- German manufacturer of professional data networks
- Outstanding expertise relating to data transmission products
- The very highest product quality for future-oriented reliability

Specialist wholesaler

- Expertise and consultation on active components and solutions
- Integrated concept for home solutions – covering everything from power and light to data
- High-speed availability

Specialist electricians

- Trained personnel for on-site data network set-up
- Custom solutions available
- Peace of mind due to superlative product quality and tested compatibility

Office

Field of application



Generic cabling in office buildings

The complete cable system – from distribution equipment to workstation

Structure of a generic communication cable system ISO/IEC 11801 and DIN EN 50173-1/2

CD	Campus distributor
BD	Building distributor
FD	Floor distributor
CP	Consolidation Point
TO	Telecommunications outlet
TE	Terminal equipment

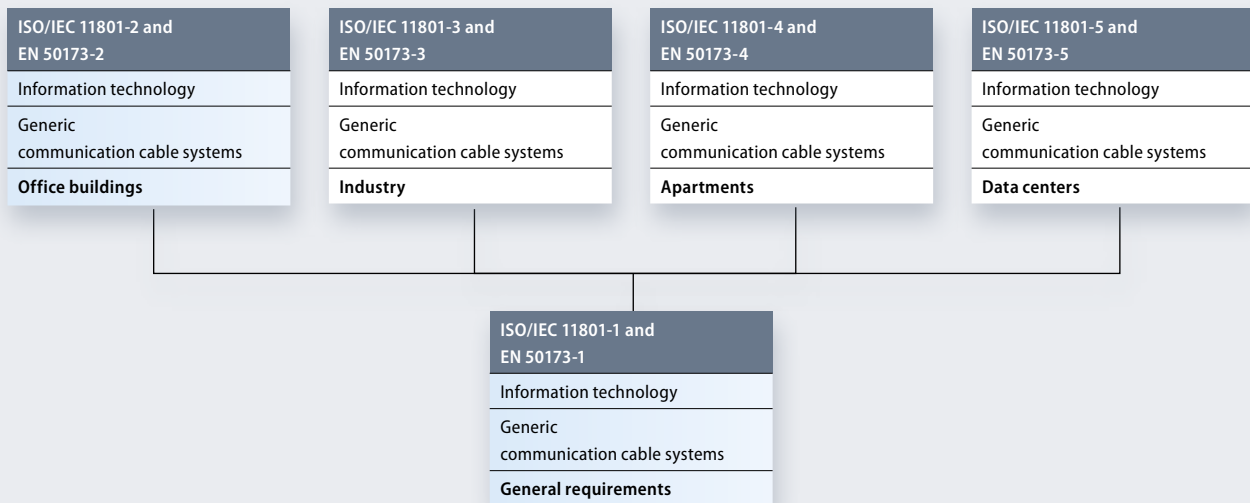
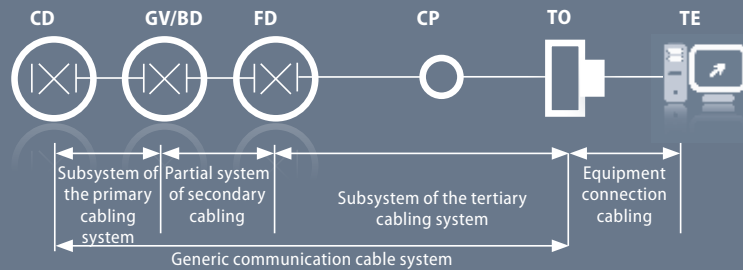

A company's future success is now heavily dependent on having a reliable and modern data processing infrastructure.

The rapid development of data bit rates and the wide range of applications require a very flexible, high-performance network infrastructure that will be able to meet the demands for the next ten years.

High-quality generic IT networks form the backbone of the business in research & development, banks, insurance companies, universities, hospitals, hotels, airports and many other sectors, providing smooth operation and financial success.

The smart use of fiber optics and copper data technologies for the backbone and horizontal wiring to the user enables cost-effective networking of standard resources such as PCs and printers, with an extension to IP telephony and multimedia applications. Other applications, such as Power-over-Ethernet (PoE), support the powering of devices such as web cameras, wireless LAN access points, IP phones and laptops via the copper data cabling.

These structured, generic communication cable systems meet both the international and European standards set by ISO/IEC 11801 and DIN EN 50173.

Industry

Field of application

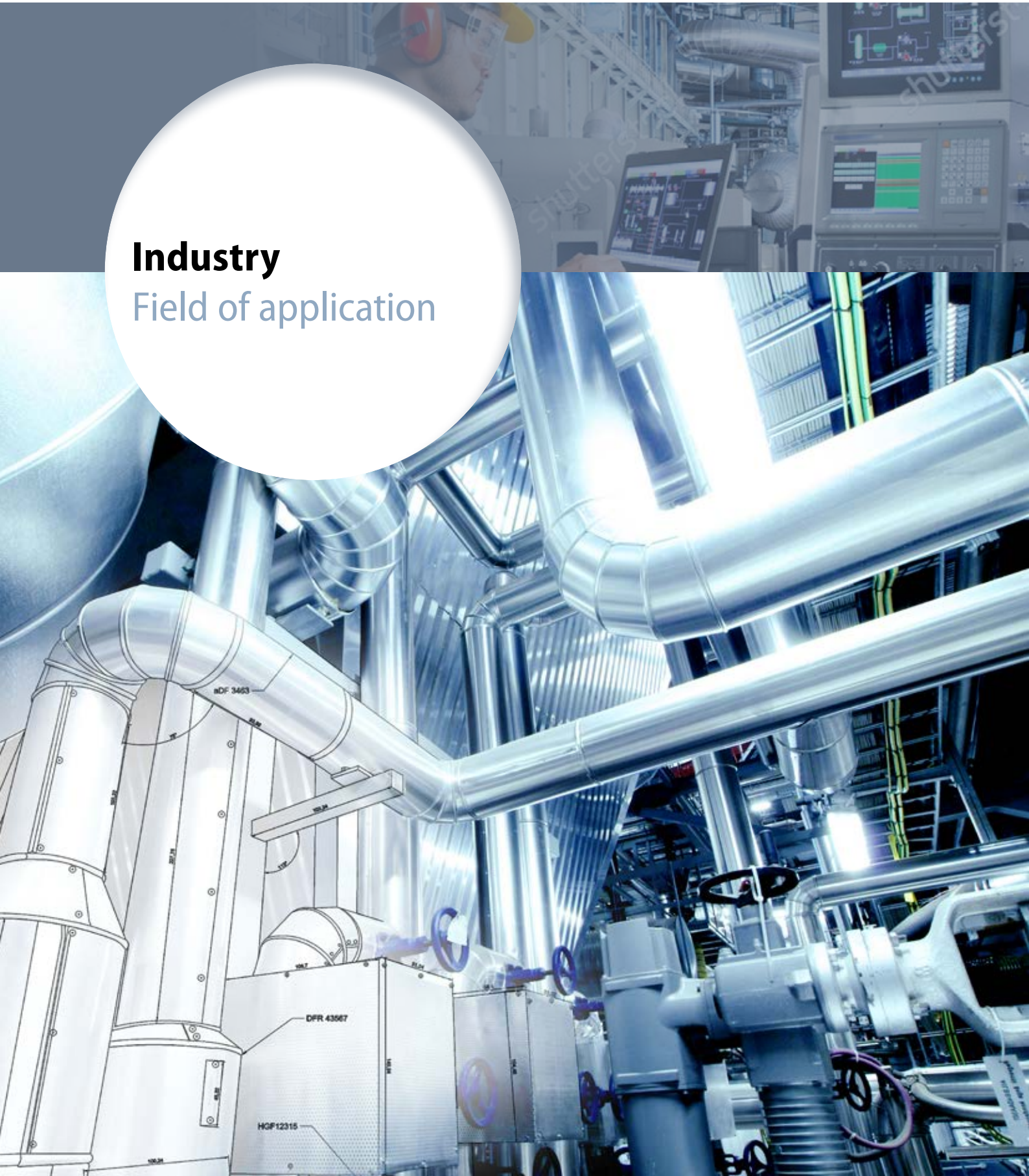

Generic cabling in the industrial environment

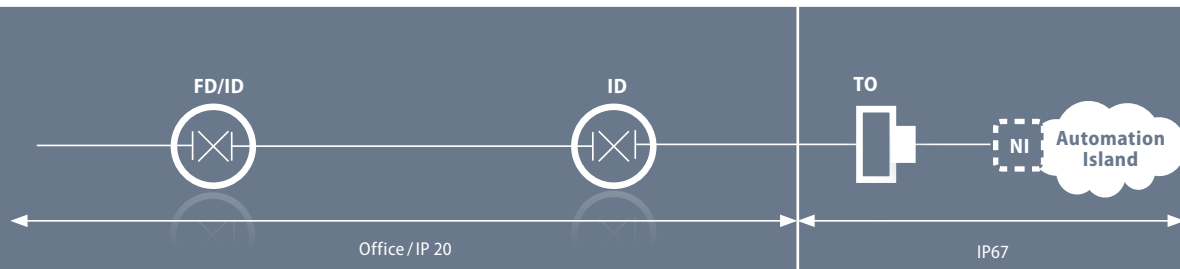

Structure of an application-neutral communications cable system in industrial locations ISO / IEC 24702 and EN 50173-3

Office / IP 20



IP67



ISO/IEC 11801 and
EN 50173-2

Information technology

Generic
communication cable systems

Office buildings

ISO/IEC 24702 and
EN 50173-3

Information technology

Generic
communication cable systems

Industry

ISO/IEC 15018 and
EN 50173-4

Information technology

Generic
communication cable systems

Apartments

ISO/IEC 24764 and
EN 50173-5

Information technology

Generic
communication cable systems

Data centers

ISO/IEC 11801 and
EN 50173-1

Information technology

Generic
communication cable systems

General requirements

Industrial IT cabling

Uniform IT platforms are increasingly used to connect different worlds

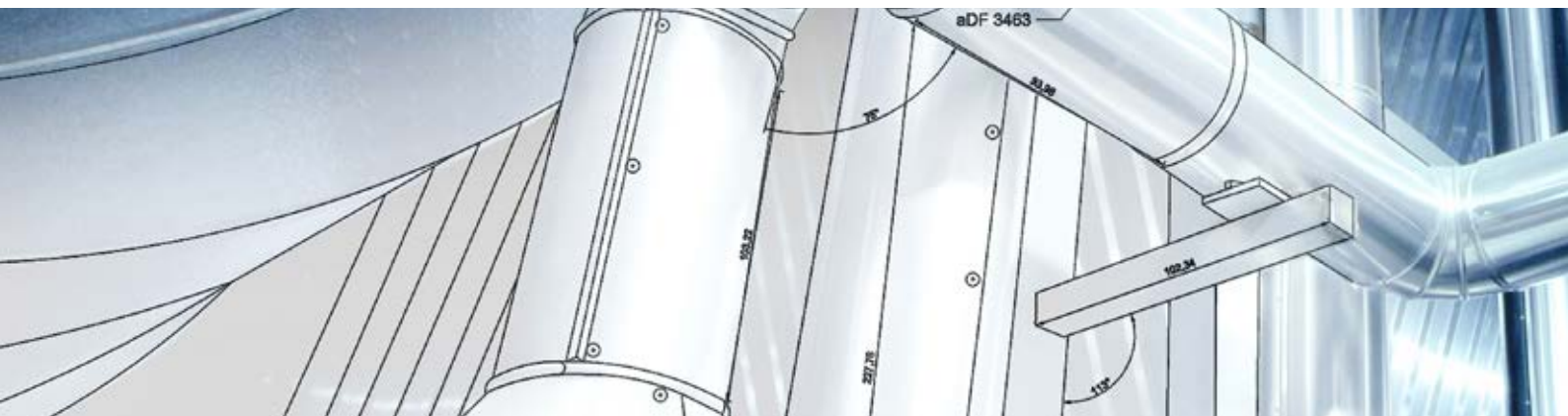

The boundaries between office and industrial cabling are becoming increasingly indistinct. The need for sales departments to receive current production data or to engage in short-term planning of production processes requires a uniform group-wide IT platform.

Manufacturers of automation and control equipment demand consistent, future-proofed international standards, while users are looking for secure investments. Ever more applications in production processes are implemented via Ethernet, reducing maintenance and operating costs. Existing standards and applications, such as PROFINET, will still need support in the years to come.

This results in a requirement for a clear separation between "application" and "network", which can only be achieved using a uniform platform as a base, combined with generic communication cabling, in both office and manufacturing environments. This requirement has been standardised in the EN 50173-1, -2, -3 series, and in the international standards ISO/IEC11801 and ISO/IEC 24702.

A consistent extension of the use of generic cabling offers enormous advantages, e.g. the

- Reduction in the assortment of products
- Deployment and distribution of mass-produced products
- Standardisation of acceptance measurements
- Reduction in training costs
- Easy trouble-shooting
- simplification of network operation, maintenance and documentation.

It is frequently observed these days that the transmission requirements in industrial environments are less challenging than those in the office area. This fact can be exploited to cut costs without compromising long-term system readiness. Since cable laying is expensive, and an expansion of technical requirements would lead to unnecessary additional costs, we recommend that data cables should be selected to meet the highest standards (Category 7 or above).

Connection technology can be limited to the necessary minimum, however, if an intelligent adaptation to changes in circumstances is possible both in terms of pathway technologies and the structural and/or production-related environment.

MICE concept

Classification of environmental conditions



MICE

	Requirement/level 1	Requirement/level 2	Requirement/level 3
M Mechanical	M ₁	M ₂	M ₃
I Ingress	I ₁	I ₂	I ₃
C Climatic/Chemical	C ₁	C ₂	C ₃
E Electromagnetic	E ₁	E ₂	E ₃

The environmental factor

As well as the electrical or optical transmission channel, the different conditions in office and industrial settings mean that the environmental factor also plays an important role.

These environmental conditions are described using four basic characteristics:

Mechanical	Mechanical properties
Ingress	Ingress protection properties
Climatic/Chemical	Climatic and chemical properties
Electromagnetic	Electromagnetic properties

The four MICE criteria are broken down into different parameters, each with three levels.

- **Office environment** M₁/I₁/C₁/E₁
- **Factory environment (light duty)** M₂/I₂/C₂/E₂
- **Machine environment (heavy duty)** M₃/I₃/C₃/E₃

The MICE classification can vary over the length of the transmission link, for example mechanical loads in the office environment are fairly low and the ingress of liquids or significant climatic and chemical loads are equally unlikely. The conditions in buildings used for industrial purposes, on the other hand, are harsher:

Mechanical loads as well as the risk of ingress of dust, dirt and liquids; high, quickly changing temperatures; solar radiation and corrosive substances can affect the components. Electromagnetic interference also influences the data communication.

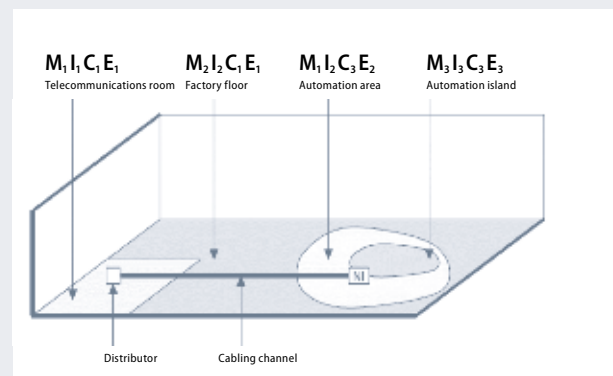



DataCenter
Field of application

Generic cabling in data centers

Structure of a generic communication cable system

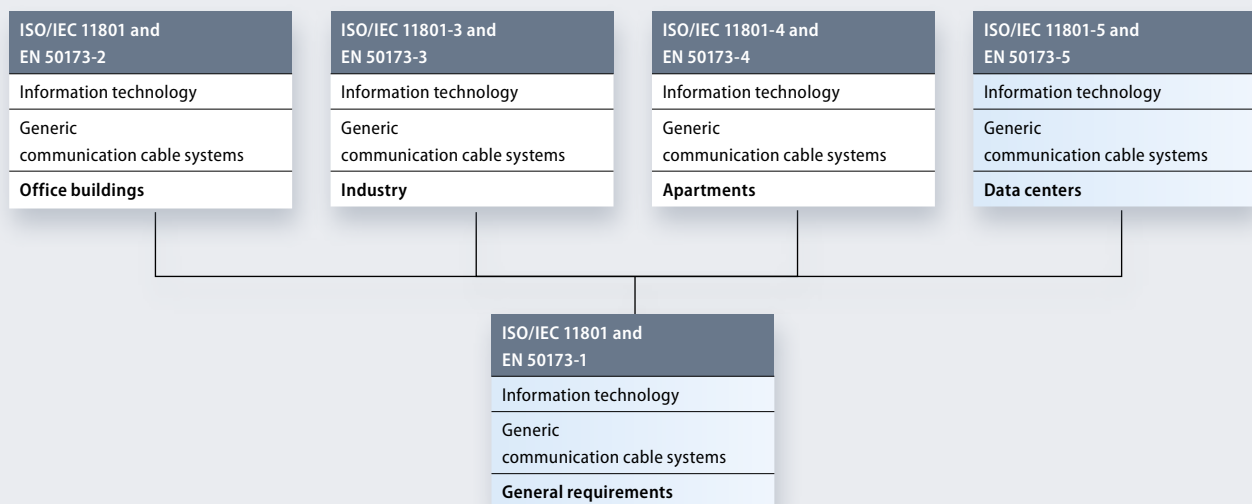
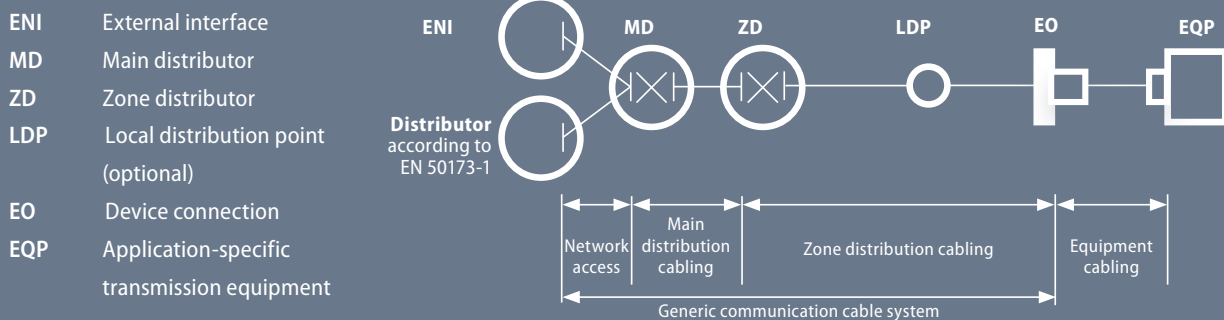

Structure

The maximum extension is 2,000 metres. In data centers the main distribution cabling is frequently designed using fiber optic technology, while in smaller networks the external network interface (ENI) is connected directly to the zone distributor (ZD). The standards describe various models for flexible and fixed connections in and between the subsystems.

According to ISO/IEC 11801-5, cabling of the main and zone distribution must meet the requirements of Class E_x for copper technology and transmission classes OF-300, OF-500 and OF-2000 for FO technology as a minimum.

Standards

Generic communication cable systems are defined in the standards EN 50173-1 and ISO/IEC 11801.

In addition, specific requirements for data centers are defined in EN 50173-5 and ISO/IEC 11801-5.

The cabling used in data centers consists of three subsystems:

- Network access cabling
- Main distribution cabling
- Zone distribution cabling

Requirements and solutions

Fast – high-quality – cost-optimised



DataCenter

The data center – the heart of a business – controls production and administrative processes. Failure here can have catastrophic consequences, so the availability of a data center must be guaranteed more or less round the clock. The cabling system is a key factor in terms of operational reliability.

Performance requirements for modern data centers

- Maximum availability, zero downtime → max. reliability
- Short installation times
- Maximum performance
- Minimal space requirement – high packing density
- Cost efficiency
- Environmental compatibility – Green IT

The diverse requirements for data centers cannot be considered separately. Optimising environmental performance can lead to a reduction in cost, for example. Investing in industrially pre-assembled components usually involves higher costs but enables installation and testing times to be reduced, thereby cutting the costs incurred by downtime.

→ High quality

With quality testing carried out at the factory, LEONI products offer built-in performance and safety.

→ Minimise downtime

Installation and commissioning take a very short time, with no need for special tools or assembly skills. This keeps downtime to a minimum.

→ Cost reduction

A GigaLine® DCLink offers cost savings of up to 55 % as compared to conventional modular systems using MPO connectivity.

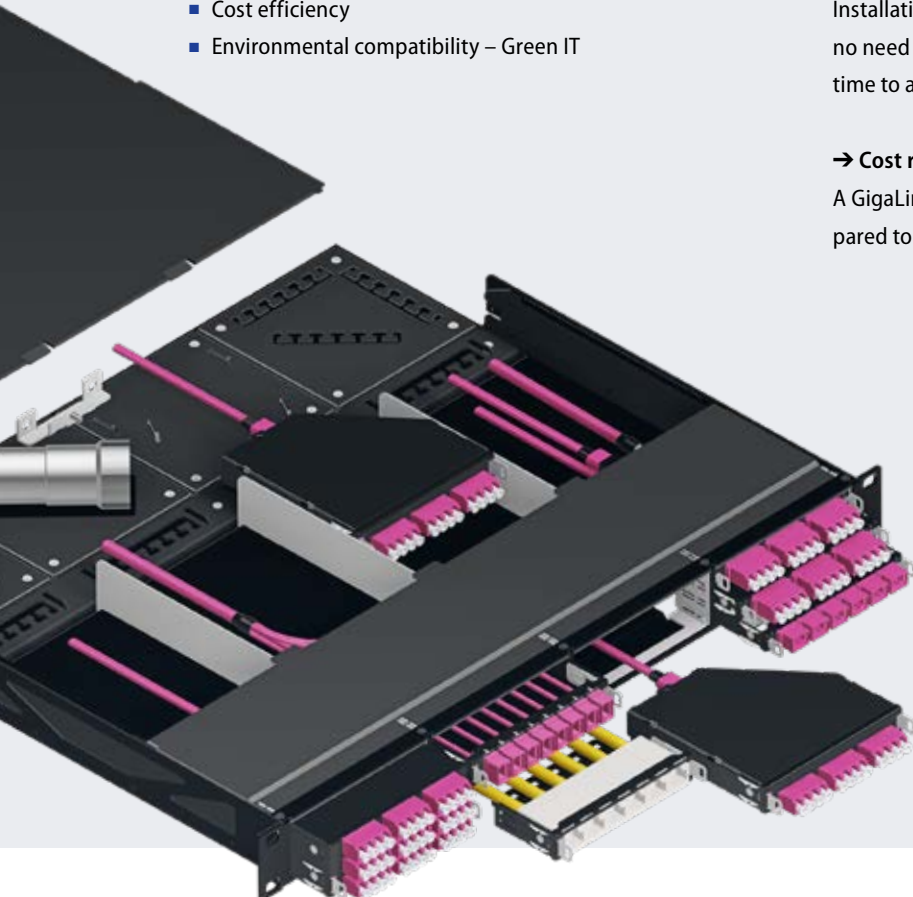

Costs per link*

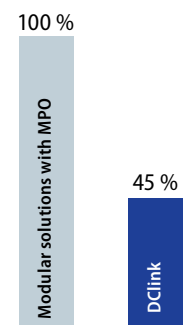

* Example:
Link length: 30 m,
Fibers: 24 x OS2,
Connector: LC Duplex

Benefits

Exceed all requirements with LEONI

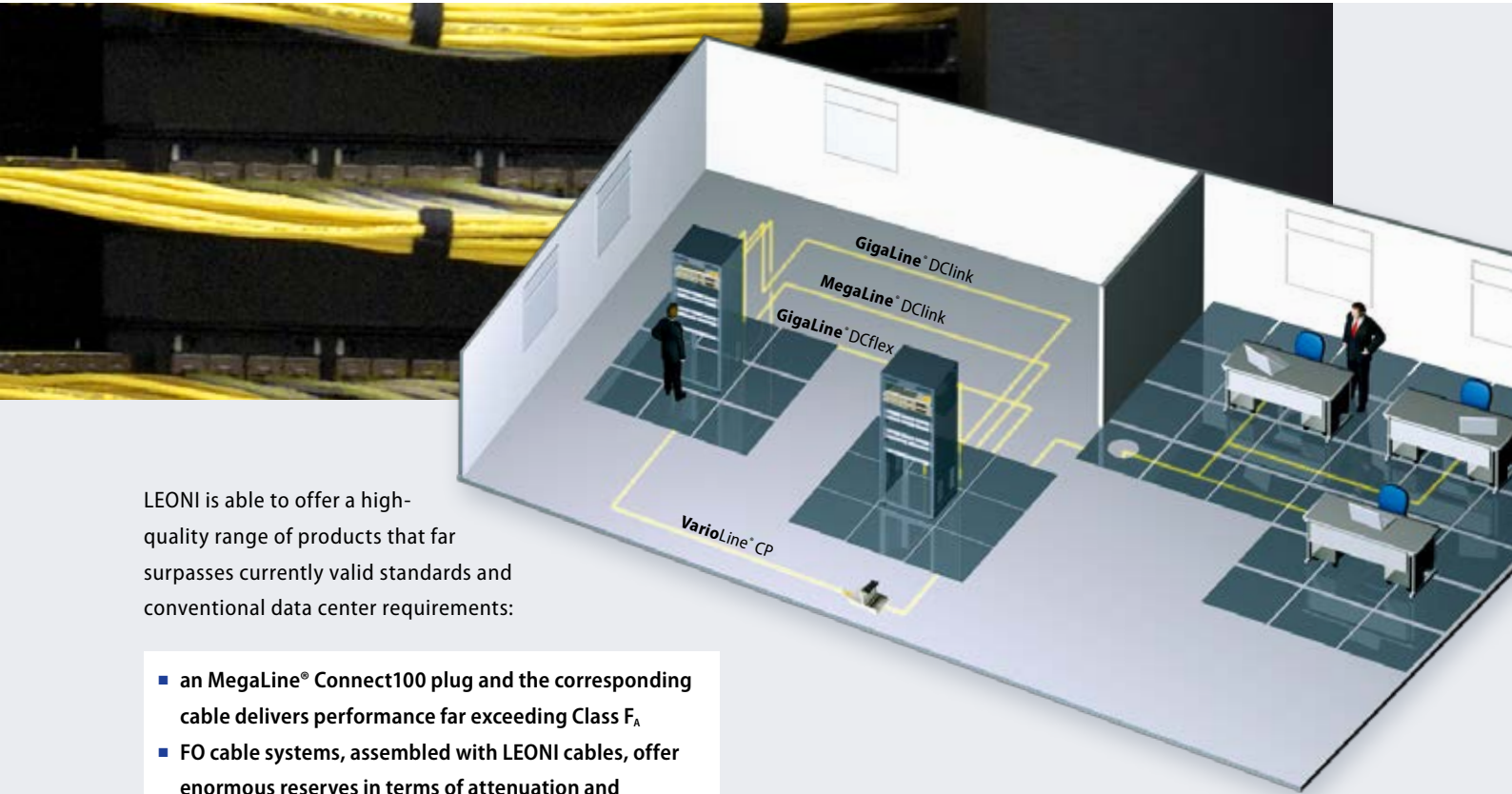

LEONI is able to offer a high-quality range of products that far surpasses currently valid standards and conventional data center requirements:

- an MegaLine® Connect100 plug and the corresponding cable delivers performance far exceeding Class F_A
- FO cable systems, assembled with LEONI cables, offer enormous reserves in terms of attenuation and bandwidth

Installation

Plug & Play solutions for copper and FO applications comprise ready-to-use factory-fitted links and the VarioLine® DCLink frame (19", 1 RU) to hold the DCLink modules. Once the link has been installed, the DCLink modules are simply inserted from the rear until they audibly click into place.

DCLink system solutions

DCLink allows the use of FO, copper or mixed set-ups in different categories. This makes on-site assembly entirely superfluous. You can also remove the modules again very easily using a simple unlocking tool.

Environmentally aware cabling

Environmentally sound materials and production methods, the possibility of recycling or ecologically viable recovery and, last but not least, the reusability of products if required – these are the factors that guarantee maximum environmental compatibility. Cables and components are free of hazardous substances.

Optimising attenuation

A GigaLine® DCLink offers up to 70 % less attenuation than conventional modular systems using MPO connectivity.

Attenuation per link*

$I_L=1.4$ dB
100 %

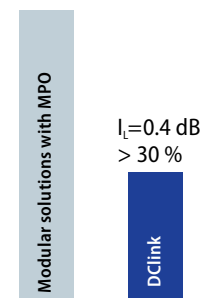

* Example:
Link length: 30 m,
Fibers: 24 x OS2,
Connector: LC Duplex

Index

Introduction	
Contents	3
The LEONI Group	4
Keeping you connected tomorrow	5
Great brands, great service	6
Technologies – investment in sustainable safety	7
Green Technology	8
MegaLine® copper data cables	10
SPACE concept	12
SPACE – Security	13
SPACE – Performance	14
SPACE – Application	16
SPACE – Construction	17
SPACE – EMC	18
PoE (Power over Ethernet) on the advance	19
Benefits of PoE	20
What to note when wiring	21
SPACE – Construction	17
SPACE – Construction	17
Fire-resistant cables acc. to the EU Construction Products Regulation	24
Safety in the event of a fire	25
Fire safety of cable systems	26
CE marking and declaration of performance	27
Fire classifications and proof of conformity	28
Overview of fire testing	29
Cable type with Euroclass B2ca s1a d1 a1	31
On the safe side with LEONI	32
Data cable colour code acc. to CPR classes	33
Type codes	34
Cable types	35
MegaLine® G20 S/F	36
MegaLine® G20 S/F Mini	38
MegaLine® G12-150 S/F	40
MegaLine® F10-130 S/F	42
MegaLine® F10-125 S/F	44
MegaLine® F10-115 S/F	46
MegaLine® F6-90 S/F	48
MegaLine® F6-90 S/F CI	50
MegaLine® E5-70 S/F	52
MegaLine® E5-70 F/F	54
MegaLine® E5-60 U/F	56
MegaLine® E2-45 U/F	58
MegaLine® E2-30 U/U	60
MegaLine® D1-20 SF/U	62
MegaLine® Pro 1500	64
MegaLine® Pro 1300	66
MegaLine® Pro 1200	68
MegaLine® Pro 1000	70
MegaLine® G20 S/F flex	72
MegaLine® F10-120 S/F flex	74
MegaLine® F6-90 S/F flex	76
MegaLine® D1-20 SF/U flex	78
MegaLine® F10-130 S/F (L)2Y	80
MegaLine® F10-130 S/F QH	82
MegaLine® F10-130 S/F V6	84

MegaLine® F10-115 S/F V	86
MegaLine® F6-90 S/F 2Y	88
MegaLine® D1-20 SF/U 2Y	90
MegaLine® D1-20 SF/U HQH	92
MegaLine® F10-120 S/F 11Y flex	94
MegaLine® F6-70 S/F 11Y flex	96
MegaLine® D1-20 SF/U flex CI	98
MegaLine® E5-60 S/U 11Y superflex	100
MegaLine® home 600	102

MegaLine® Connect100 Cu connectivity	104
Ready for 40 Gbit/s	106
40 GBASE-T over copper	108
System overview	110
Cable plugs	112
Jack modules	113
Interface	114
Wall outlets	115
Patch panel 19"/1RU	116
Patch panel 19"	117
DIN rail housing	117
Accessories & cable assembly tools	118

MegaLine® Connect45 MegaLine® Connect45 Pro Cu connectivity	120
MegaLine® Connect45	122
LEO and LED function	123
Connection components	124
Installation options	125
System overview	126
Cable plugs	128
Jack modules in VK format	129
Jack modules in Keystone® format	130
Jack modules in ELine format	132
RJ45 plugs	133
Patch panels 19" in Keystone® format	134
Patch panels 19" in ELine format	134
Patch panels 19" unequipped	135
Wall outlets for Keystone® jack modules	136
Wall outlets for VK jack modules	137
Accessories & tools	138
MegaLine® Connect45 Pro	139
System overview	139
Jack modules in Keystone® format	140
Patch panel 19" unequipped	141
Wall outlets for Keystone® jack modules	141

MegaLine® Cu patch cords/trunk cables	142
Patch cord RJ45/RJ45 Cat. 5/100 MHz	144
Patch cord RJ45/RJ45 Cat. 6/250 MHz	145
Patch cord RJ45/RJ45 Cat. 6/500 MHz	146
Patch cord RJ45/RJ45 Cat. 6 _n /500 MHz	147
LED patch cords RJ45/RJ45 Cat. 6/500 MHz	148

LED patch cords RJ45/RJ45 Cat. 6 _n /500 MHz	149
Industrial patch cords RJ45/RJ45 Cat. 5/100 MHz	150
Industrial patch cords RJ45/RJ45 Cat. 6/500 MHz	151
Trunk cables	152
Consolidation Point cables	153
Patch cord TERA™	154
Patch cord ARJ45™	156
Trunk cables	157
Consolidation Point cables	159
Accessories for LED patch cords	161
Accessories for patch cords	161

VarioLine® system periphery in copper and fiber	162
Consolidation Point programme	165
Consolidation Point housing	166
Underfloor systems	169
System overview	170
Support plates for underfloor systems for the installation of wall boxes	172
Support plates for underfloor systems for the installation of adapter plates	173
Adapter plates for underfloor systems	174
Support plates for underfloor systems	176
Blind cover	177

MegaLine® acceptance measurement	178
Acceptance measurement Class E	179
Acceptance measurement Class E _n	180
Acceptance measurement Class F _n	181
Channel	182
Permanent Link	183
Alien crosstalk	184

MegaLine® @home One network – no limits	186
MegaLine®@home – all data in one	187
Convenience for all	188
Building technology and multimedia Planning example	189
Product range	190
LEONI & Partner	191

Office applications	192
Generic cabling in office buildings	193
Industrial applications	194
Generic cabling in the industrial environment	195
Industrial IT cabling	196
MICE concept	197
Data center applications	198
Generic cabling in data centers	199
Requirements and solutions	200
Benefits	201

LEONI news

Additional catalogues for MegaLine®, GigaLine® and VarioLine® connection systems are available online.

We keep you up-to-date on the latest LEONI news and market developments with current information services such as the LEONI newsletter.

Visit us at www.leoni-data.com



Visit our homepage:



Here will find details of

- Product and company news
- Professional articles
- Trade fairs, seminars and road shows
- Texts for invitations to tenders
- Standardisations/certification programmes

Find out more:

Business Unit Datacom
www.leoni-data.com

LEONI Kerpen GmbH

Zweifaller Straße 275–287

52224 Stolberg

Germany

Phone +49 (0)2402 17 1

Fax +49 (0)2402 75154

E-mail datacom@leoni.com