

# Plexo 2P+ E socket outlets German standard

Cat. Nos : 695 71 - 696 39 - 697 33/71  
698 33/34/68/69

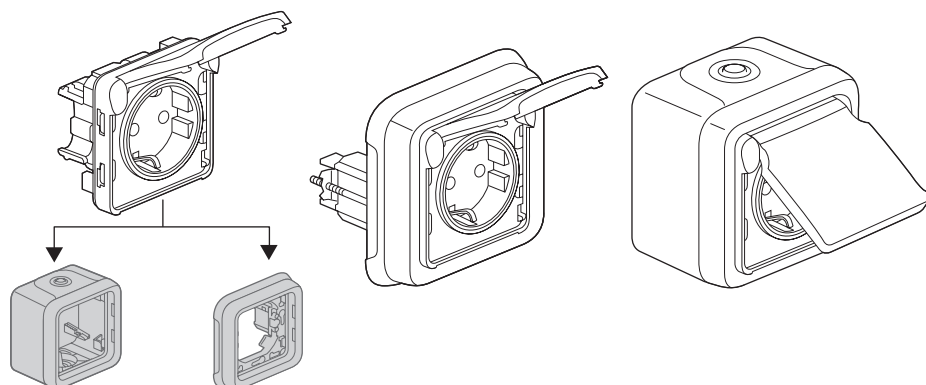

CONTENTS	Page
1. Technical characteristics	1
2. Range	1
3. Installation	1-2
4. Dimensions	3
5. General characteristics	3/4
6. Maintenance	4
7. Specific utilisations	4
8. Equipment and accessories	5
9. Compliances and approvals	5

## 1. TECHNICAL CHARACTERISTICS

Waterproof electrical equipment for residential and professional technical installations (garages, cellars, car parks, workshops, industrial kitchens, etc.) and outdoor environments (terraces, gardens, camp sites, etc.).

German standard 16 A 250 V AC socket outlets, with protection cover and screw connection terminals, accepting domestic 2-pin and 2-pin + E plugs as per German standard.

### 2. RANGE

Cat. No(s)	Version
695 xx 696 xx	Composable
697 xx 698 xx	Surface-mount complete Flush-mount complete

Type	Cat. No(s)	Characteristics	Connection	Weight
COMPOSABLE	2P+E socket German standard 695 71 696 39	16 A 250 V~	Screw terminals	56 g
SURFACE MOUNTING COMPLETE	2P+E socket German standard 697 33 697 71	16 A 250 V~	Screw terminals	140 g
FLUSH-MOUNT COMPLETE	2P+E socket German standard screw fixing 698 33 698 69	16 A 250 V~	Screw terminals	100 g

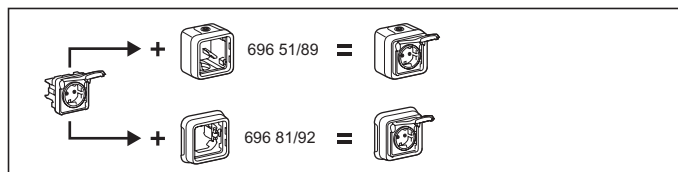

## 3. INSTALLATION

### 3.1 Surface mounting

- Back body is mounted on the support using two screws, max. Ø 3 to 4 mm.

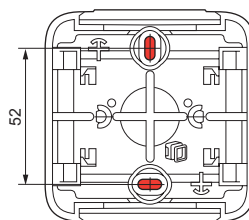

- Replaces former series Plexo 55

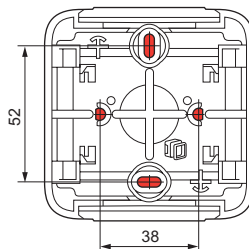

### 3.2 Flush mounting

- Screw-mounted in flush-mounting box.

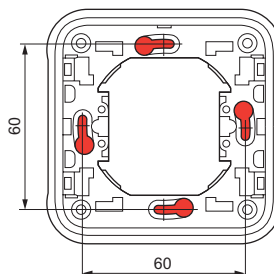

# Plexo 2P+ E socket outlets

## German standard

Cat. Nos : 695 71 - 696 39 - 697 33/71  
698 33/34/68/69

### 3. INSTALLATION (continued)

- Mounting on base plate using 4 screws, Ø 4 mm.
- Opening cut in base-plate, Ø 60 - 70 mm using a circular saw or a punch.

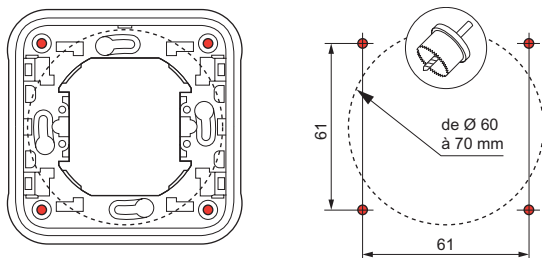

#### 3.3 Connection to conductors

- Screw terminal mechanisms

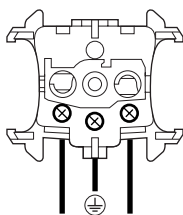

Tunnel terminals supplied open, screw backed off and locked. The terminals accept cross-sections between 1.5 mm<sup>2</sup> and 2.5 mm<sup>2</sup> (1 or 2 wires).

Max. tightening torque : 0.8 Nm

Screwdriver required : flat blade 3.5 to 5 mm, or Phillips No.1

Wires must be stripped over a length of 8 mm.

#### 3.4 Connection to conduits

Conduit types :

- IRL : formerly IRO, insulating rigid smooth tube
  - ICA : insulating flexible bendable corrugated tube
  - ICTA : insulating flexible transversally bendable elastic corrugated conduit
  - ICTL : insulating flexible transversally bendable elastic smooth conduit
- } Ø 16 - 25 mm

Cables (examples) :

- rigid conductors : U - 1000R2V 3G2.5
- flexible conductors : H07 RN - F 3G2.5

End pieces: flexible with membranes, 2 removable types.

- entry gland with 1 entry supplied with 1 gang boxes (top and bottom)
- entry gland with 1 entry supplied with 2 gang and 3 gang boxes (top)
- entry gland with 2 entries supplied with 2 gang and 3 gang boxes (bottom)

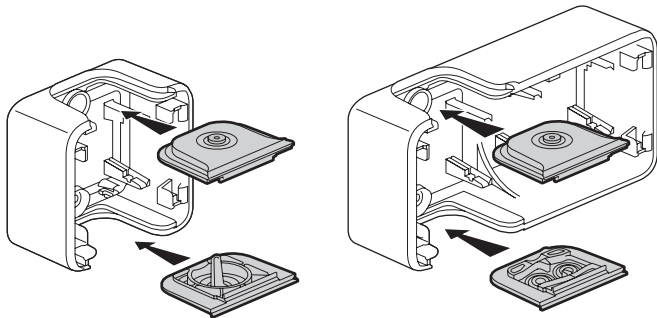

### 3. INSTALLATION (continued)

#### 3.4 Connection to conduits (continued)

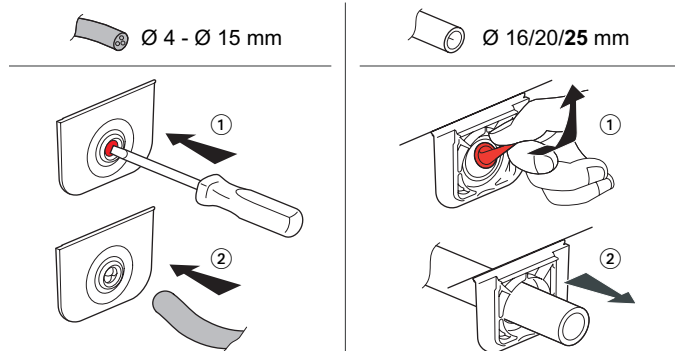

Also available as accessories :

- 695 96 grey entry gland 1 entry
- 695 99 grey entry gland 2 entries
- 696 46 white entry gland 1 entry
- 696 49 white entry gland 2 entries

#### 3.5 Assembly

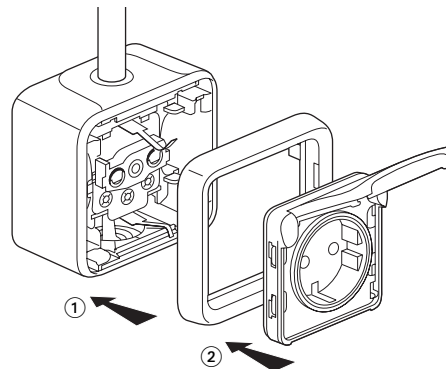

IP55 sealing on front part (cover) on the box is ensured by rotating four 1/4 turn fixings.

The direction of rotation of each 1/4 turn fixing is shown by an arrow on the cover.

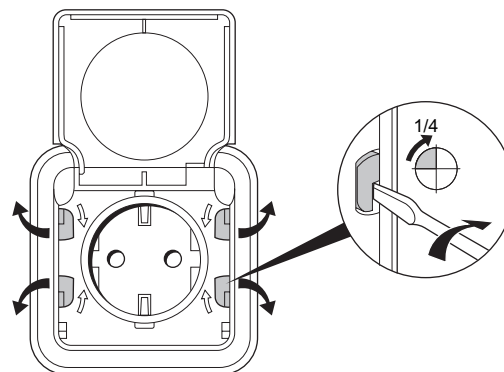

# Plexo 2P+ E socket outlets

## German standard

Cat. Nos : 695 71 - 696 39 - 697 33/71  
698 33/34/68/69

### 4. DIMENSIONS

Composable

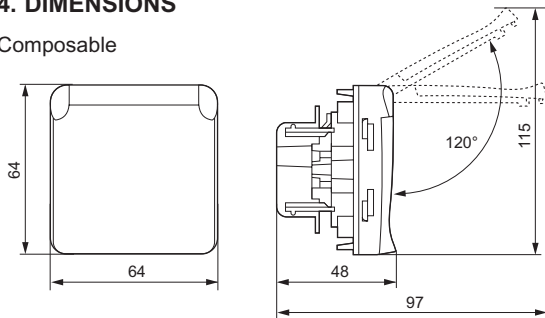

Surface-mounting

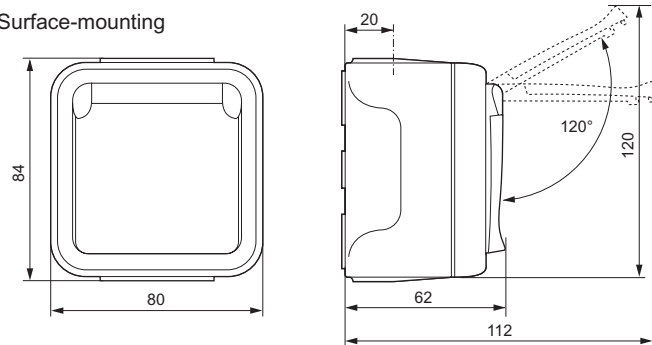

Flush-mounting

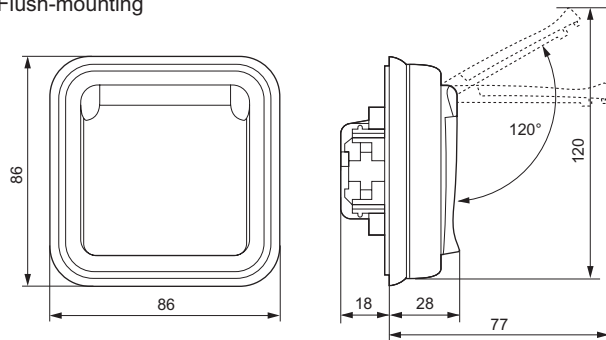

### 5. GENERAL CHARACTERISTICS

#### 5.1 Mechanical characteristics

Protection rating :

- IP 55 IK 07, flap closed

#### 5.2 Material characteristics

##### Materials

Box, support : PP (filled Polypropylene)

Plate, flap : ABS (Acrylonitrile-Butadiene-Styrene)

Entry gland : PP + SEBS (Styrene-Ethylene-Butadiene-Styrene)

Mechanism : PC (Polycarbonate)

#### 5.3 Resistance to chemical agents

Characteristics

Acetone	-
Acetic acid, 10% solution	+
Acetic acid, $\geq 30$ % solution	+
Aminosulfonic acid	-
Boric acid *	+
Hydrobromic acid, 47% solution	-
Hydrochloric acid *	+
Chromic acid	+
Citric acid *	+
Hydrofluoric acid *	-
Formic acid	-
Lactic acid *	+
Linoleic acid	-
Maleic acid	+
Nitric acid, 30% solution	-

Acetone	-
Acetic acid, 10% solution	+
Acetic acid, $\leq 30$ % solution	+
Aminosulfonic acid	-
Boric acid *	+
Hydrobromic acid, 47% solution	-
Hydrochloric acid *	-
Chromic acid	+
Citric acid *	+
Hydrofluoric acid *	-
Formic acid	-
Lactic acid *	+
Linoleic acid	-
Maleic acid	+
Nitric acid, 30% solution	-
Nitric acid, 50% solution	-
Perchloric acid, 10% solution	+
Phenol sulfonic acid	-
Phosphoric acid *	-
Sulphuric acid	+
Tannic acid *	-
Tartaric acid *	+
Ethanol	+
Isopropyl alcohol	+
Methanol	-
Phenyl ethanol, 100% solution	-
Ammonia	+
Baths for electroplating	
- Bright silver bath	+
- Bright cadmium bath	+
- Chromium bath (50°C)	+
- Copper bath (with potassium cyanide)	+
- Copper bath (acid)	+
- Cleaning bath with chemical copper plating	+
- Brass bath	+
- Bright nickel bath	+
Barium	
- Barium chloride *	+
- Barium hydroxide *	+
- Barium nitrate *	-
Benzene	-
Beer	+
Lime chloride *	+
Cobalt chloride *	-
Copper chloride *	-
Ferrous chloride *	-
Manganese chloride	-
Mercury chloride *	-
Methylene chloride	-
Chlorine vapour	-
Sea water	+
Fertiliser	+
Epichlorhydrine	-
Heavy spirit	-
Mineral spirit	-
Turpentine spirit	-
Essence oils	+
Linseed oil	+
Lubricating oil	+
Machine oil	+
Mineral oil	+
Liquid paraffin	+
Fish oil	+
Castor oil	+
Silicone oil	+
Humus	+
Aqueous hydrogen sulphide	+
Sodium hypochlorite, 10% solution	+
Fruit juice	+
Milk	+
Chlorinated detergent	+
Margarine	+
Fuel oil	+

# Plexo 2P+ E socket outlets

## German standard

Cat. Nos : 695 71 - 696 39 - 697 33/71  
698 33/34/68/69

### 5. GENERAL CHARACTERISTICS (continued)

#### 5.3 Resistance to chemical agents (continued)

Caustic soda, ≤ 40% solution	.....	+
Monomer styrene	.....	-
Sugar	.....	+
Trichloroethylene	.....	-
Urine	.....	+
Wine	.....	+

\* all concentrations in aqueous solution

**Interpretation : + resistant - unstable**

This information is given as a guide only and can not be construed as an undertaking on the part of the manufacturer.

Please consult us in the case of specific utilisation.

#### 5.4 Resistance to ultra-violet radiation

No significant change after 7-day test with light intensity 550 W/m<sup>2</sup> (Lab method colorimeter test).

#### 5.5 Resistance to salt spray : 7 days (168 hrs)

#### 5.6 Electrical characteristics

- Self-extinguishing in accordance with IEC 60695-2-11 : components (or parts) required to secure live parts : 850°C components (or parts) not required to secure live parts : 650°C
- Voltage - Current - Frequency  
16 A 250 V~ 50 Hz in accordance with IEC 60884 -1

#### 5.7 Climatic characteristics

Storage and utilisation temperature : - 25°C to + 60°C

### 6. MAINTENANCE

Surfaces may be cleaned using a cloth, either dry or with soapy water. Do not use acetone, spirits or trichloroethylene.

**Caution :** conduct preliminary tests before using any specific cleaning product.

### 7. SPECIFIC UTILISATIONS

Installations with profile.

The Plexo profile distribution system provides :

- distribution, protection and branch connection of various wires and cables in an electrical installation.
- a profile, finishing and routing accessories (profile joint, weatherproof universal junction, flat angle, internal angle, external angle, branch connection, bracket)
- a new solution for installing weatherproof surface mounting switchgear installations in domestic and occasionally tertiary technical situations.
- optimum safety and reliability due to compliance with standard NFC 68-104 (IP 42, IK 07).

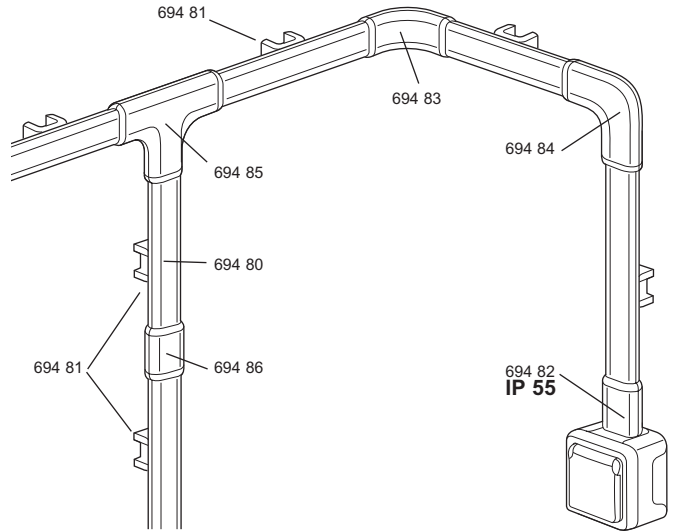

Cat. No.	Description
694 80	Plexo profile, length 2.00 m capacity equivalent to a Ø 25 mm IRL
694 81	Plexo profile bracket
694 82	IP55 weatherproof universal connection
694 83	Plexo profile internal/external angle
694 84	Plexo profile flat angle
694 85	Plexo profile tee
694 86	Plexo universal junction







- Refer to the specific technical sheet for Plexo profile, technical sheet : F00386FR/00.

# Plexo 2P+ E socket outlets

## German standard

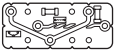

Cat. Nos : 695 71 - 696 39 - 697 33/71  
698 33/34/68/69

### 8. ÉQUIPEMENTS ET ACCESSOIRES

Description	Uses	Cat. No.	Colour
Entry gland 1 entry 	Used to provide an aesthetic connection between boxes and cables up to Ø 16 mm inclusive	695 96	Grey
		696 46	White
Entry gland 2 entries 		695 99	Grey
		696 49	White
Drilling template 	Used for fast identification of mounting centre distances of all boxes	695 97	-
Set of 4 covers 	Used to blank mounting holes at bottom of boxes	695 98	Grey
Multi-cable grommet	(PG) Ø 7 - 14 mm	696 53	
	(ISO) Ø 9 - 14 mm	696 54	
Standard claw 	Clips on to all 1-gang flush-mounting supports	849 00	-
Long claw 		849 01	-
Tap-off terminal 	Direct connection after simply stripping rigid conductors Terminal capacity : 0.75 - 2.5 mm <sup>2</sup>	343 22	

### 9. COMPLIANCES AND APPROVALS

- Products compliant with standards :
  - VDE 0620
  - International IEC 60884-1

Quality label	Standard	Certificate
	VDE 0620	Pending
	ÖVE/ÖNORM IEC 60884-1	31/05/2007
	NP 1260	Pending